



POWER PROTECTION

# Datawave<sup>®</sup> Magnetic Synthesizer

15 kVA to 75 kVA; 50 and 60 Hz

Installation, Operation,  
& Maintenance Manual

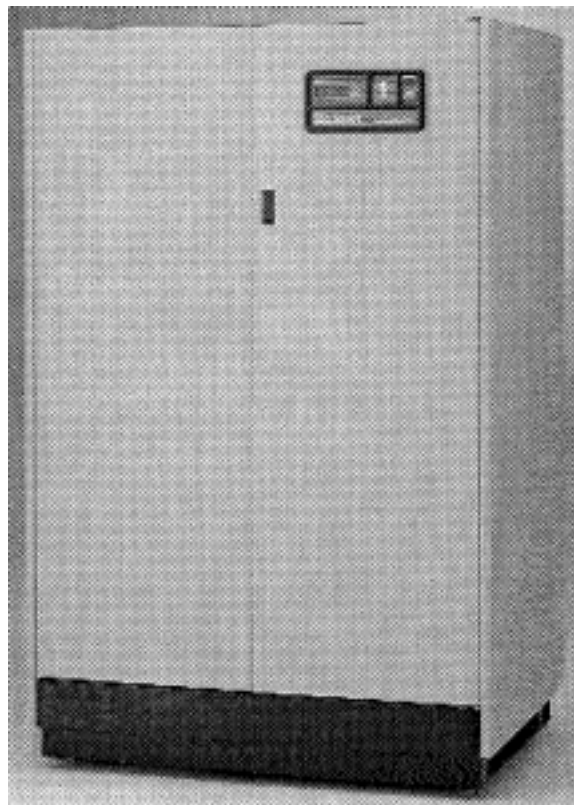

---

---

---

# TABLE OF CONTENTS

<b>IMPORTANT SAFETY INSTRUCTIONS</b> .....	<b>1</b>
<b>1.0 INSTALLATION INSTRUCTIONS</b>	
1.1 Unpacking and Installation .....	3
1.1.1 Unpacking and Preliminary Inspection .....	3
1.1.2 Handling Considerations .....	3
1.1.3 Unit Preparation .....	6
1.1.4 Location Considerations .....	6
1.1.5 Floor Pedestal Installation (50-75 kVA Units) .....	8
1.2 Power and Control Wiring .....	9
1.2.1 Input Power Connections .....	9
1.2.2 Junction Box Installation (if used) .....	16
1.2.3 System Grounding .....	18
1.2.4 Grounding Electrode Conductor .....	18
1.2.5 Output Power Connections .....	19
1.2.6 Control Wiring Connections .....	20
<b>2.0 EQUIPMENT INSPECTION AND START-UP</b>	
2.1 Internal Inspection .....	23
2.2 Start-Up .....	23
<b>3.0 INSPECTION AND START-UP CHECKLIST</b>	
3.1 Inspection .....	25
3.2 Start-Up .....	26
3.3 Monitoring System Check Out .....	28
3.4 Equipment Connection Check Out (For Units With Distribution Cables) .....	29
<b>4.0 OPERATING INSTRUCTIONS</b>	
4.1 Start-Up Procedures .....	30
4.1.1 Emergency Shutdown .....	30
4.1.2 Normal System Shutdown .....	30
4.1.3 Normal System Turn ON .....	30
4.1.4 Manual Restart .....	30
4.2 Basic Monitor Panel (Units Without Monitoring) .....	31
4.3 Power Monitor Panel .....	31
<b>5.0 MAINTENANCE</b>	
5.1 Corrective Maintenance (Repair) .....	35
5.2 Preventive Maintenance (Inspection & Cleaning) .....	35
5.3 Datawave Magnetic Synthesizer Check .....	36

---

## FIGURES

Figure i	Typical Cabinet and Floor Planning Dimensional Data, 15-30 kVA	2
Figure 1	Typical Cabinet and Floor Planning Dimensional Data, 15-30 kVA	4
Figure 2	Typical Cabinet and Floor Planning Dimensional Data, 50-75 kVA	5
Figure 3	Recommended Minimum Service and Ventilation Clearances	7
Figure 4	Floor Pedestal Details	8
Figure 5	Electrical Field Connection Locations, Self-Contained (SC) 15-30 kVA Units	10
Figure 6	Electrical Field Connection Locations, Conditioning Alone (CA) 15-30 kVA Units	11
Figure 7	Electrical Field Connection Locations, Self-Contained (SC) 50-75 kVA Units	12
Figure 8	Electrical Field Connection Locations, Conditioning Alone (CA) 50-75 kVA Units	13
Figure 9	Datawave Bypass Configuration	14
Figure 10	Typical Junction Box Connections	17
Figure 11	Typical Datawave Grounding Arrangement	19
Figure 12	Simplified Shutdown Circuit	20
Figure 13	Typical Control Wiring for Units Without Monitoring	21
Figure 14	Typical Control Wiring for Units With Power Monitoring	22

## TABLES

Table 1	Heat Output	7
Table 2	Suggested Minimum Wire Size	15
Table 3	Main Input Circuit Breaker Lug Size and Interrupting Rating	16
Table 4	Grounding Electrode Size	18
Table 5	Torque Specifications (Unless Otherwise Labeled)	24
Table 6	RS-232 ASCII Port Customer Commands	33
Table 7	Monitored Parameters Data Definitions	34

---

## IMPORTANT SAFETY INSTRUCTIONS

---



### NOTE

*Read the entire manual before installing or operating the system.*



### WARNING

**THE SHIPPING BANDS MAY BE UNDER TENSION. USE APPROPRIATE EYE, FACE, AND HAND PROTECTION TO SAFEGUARD AGAINST INJURY FROM BAND BACKLASH.**



### WARNING

**VERIFY THAT ALL INCOMING LINE VOLTAGE (POWER) AND LOW VOLTAGE (CONTROL) CIRCUITS ARE DE-ENERGIZED AND LOCKED OUT BEFORE INSTALLING CABLES OR MAKING CONNECTIONS, WHETHER IN THE JUNCTION BOX OR IN THE UNIT.**

**EQUIPMENT INSPECTION AND START-UP SHOULD BE PERFORMED ONLY BY TRAINED PERSONNEL. LETHAL VOLTAGES ARE PRESENT DURING START-UP PROCEDURES. ELECTRICAL SAFETY PRECAUTIONS MUST BE FOLLOWED THROUGHOUT INSPECTION AND START-UP.**

**ONLY QUALIFIED SERVICE PERSONNEL SHOULD PERFORM MAINTENANCE ON THE DATAWAVE SYSTEM. ALL VOLTAGE SOURCES TO THE UNIT MUST BE DISCONNECTED BEFORE INSPECTING OR CLEANING WITHIN THE CABINET.**

**LETHAL VOLTAGES EXIST WITHIN THE EQUIPMENT DURING OPERATION. OBSERVE ALL WARNINGS AND CAUTIONS IN THIS MANUAL. FAILURE TO COMPLY MAY RESULT IN SERIOUS INJURY OR DEATH. OBTAIN QUALIFIED SERVICE FOR THIS EQUIPMENT AS INSTRUCTED.**

**THE MONITORING SYSTEM CONTAINS A LITHIUM BATTERY FOR MEMORY BACK-UP. DANGER OF EXPLOSION IF BATTERY IS INCORRECTLY REPLACED. REPLACE ONLY WITH SAME OR EQUIVALENT TYPE. DISPOSE OF USED BATTERIES ACCORDING TO MANUFACTURER'S INSTRUCTIONS.**



### NOTE

*The unit should not be loosened from the shipping pallet until after all handling by fork lift or pallet jack is completed.*

*All power and control wiring should be installed by licensed electricians and must comply with the NEC and applicable codes.*

**Figure i Typical Cabinet and Floor Planning Dimensional Data, 15-30 kVA**

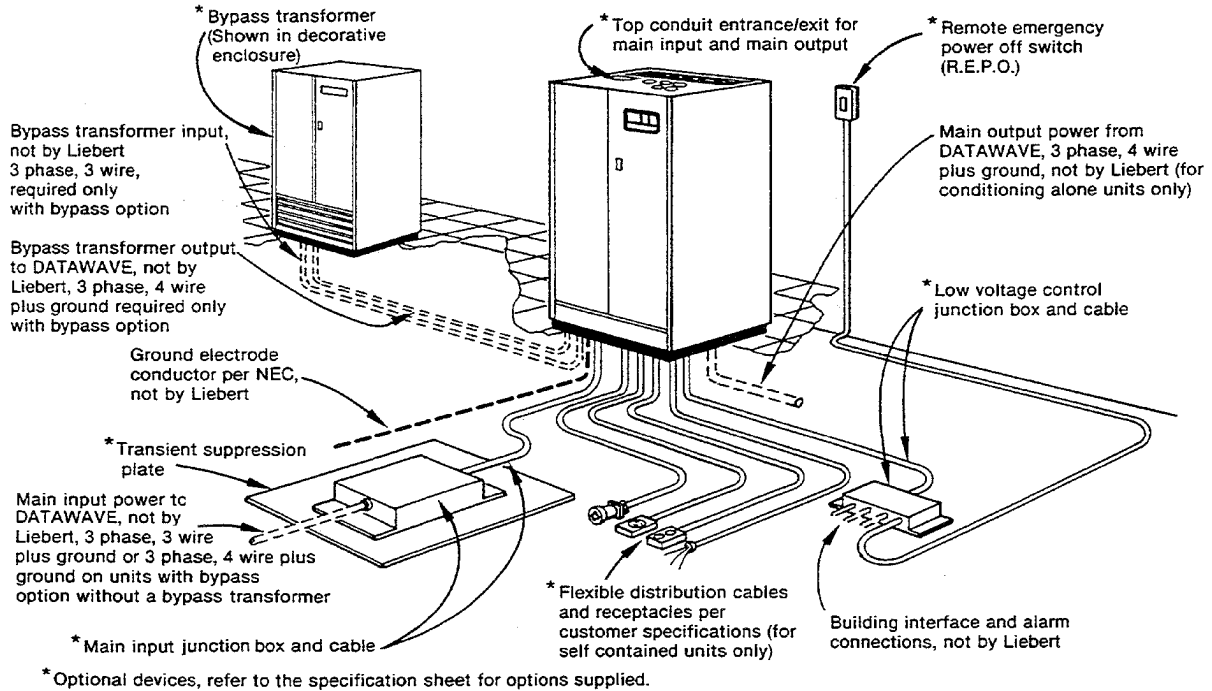

SUGGESTED MINIMUM WIRE SIZE DATA											
MAIN INPUT					MAIN OUTPUT (For Conditioning Alone Units Only)						
VOLTAGE	(X)	kVA	FLA	OPD	Suggested feeder wire size (AWG)	VOLTAGE	(X)	kVA	FLA	OPD	Suggested feeder wire size (AWG)
208V	—	15	47	60	6	208V	—	15	42	60	6
	—	20	62	80	4		—	20	56	70	4
	—	30	93	125	1		—	30	83	110	2
	—	50	155	200	000		—	50	139	175	00
	—	75	233	300	350 kcmil		—	75	208	300	350 kcmil
240V	—	15	41	60	6	—	—	15	—	—	—
	—	20	54	70	4		—	20	—	—	—
	—	30	81	100	2		—	30	—	—	—
	—	50	135	175	00		—	50	—	—	—
	—	75	202	250	250 kcmil		—	75	—	—	—
380V	—	15	26	40	8	380V	—	15	23	30	10
	—	20	34	45	8		—	20	30	40	8
	—	30	51	70	4		—	30	46	60	6
	—	50	85	110	2		—	50	76	100	3
	—	75	127	175	00		—	75	114	150	0
415V	—	15	23	30	10	415V	—	15	21	30	10
	—	20	31	40	8		—	20	28	40	8
	—	30	47	60	6		—	30	42	60	6
	—	50	78	100	3		—	50	70	90	3
	—	75	117	150	0		—	75	104	150	0
480V	—	15	20	25	10	480V	—	15	18	25	10
	—	20	27	40	8		—	20	24	30	10
	—	30	40	50	8		—	30	36	45	8
	—	50	67	90	3		—	50	60	80	4
	—	75	101	125	1		—	75	90	125	1
575V	—	15	17	25	10	575V	—	15	15	20	12
	—	20	23	30	10		—	20	20	25	10
	—	30	34	45	8		—	30	30	40	8
600V	—	50	54	70	4	600V	—	50	48	60	6
	—	75	81	110	2		—	75	72	90	3

**NOTE:** Input feeder and output feeder wire sizes listed in the table to the right are the minimum feeder sizes recommended based on NEC 1980 table 310-16 using 75°C copper conductor. Larger wire sizes may be required because of voltage drop, excessive neutral current or supply OPD. Refer to the installation manual for detailed installation procedure.

**FLA** = Full Load Amp of Datawave Magnetic Synthesizer.

**OPD** = Overcurrent Protection Device inside Datawave Magnetic Synthesizer.

---

## 1.0 INSTALLATION INSTRUCTIONS

---

### 1.1 Unpacking and Installation



#### NOTE

*Read the entire manual before installing and operating this system. Upon receipt of a Datawave Magnetic Synthesizer, the installer should perform the following steps to assure a quality installation.*

#### 1.1.1 Unpacking and Preliminary Inspection

A quality installation begins on the receiving dock.

1. **Inspect the shipping crate(s)** for damage or signs of mishandling before unpacking the unit(s). Check Shock-Watch indicator.
2. **Open the shipping crates carefully.** (Use care to avoid puncturing the container with sharp objects that would damage the contents.)
3. **Remove the packing and vapor barriers and inspect the equipment** for any obvious shipping damages.



#### NOTE

*The unit should not be loosened from the shipping pallet until after all handling by fork life or pallet jack is completed. Complete internal inspection should be accomplished only after equipment positioning and prior to electrical hookup.*

4. **If any damaged as a result of shipping is observed,** immediately file a damaged claim with the shipping agency and forward a copy to:

Liebert Corporation  
1050 Dearborn Drive  
P.O. Box 29186  
Columbus, Ohio 43229 USA

#### 1.1.2 Handling Considerations

The Datawave module (and cables, if furnished) is bolted to a wooden pallet to allow handling by fork-lift equipment.

**Easily moved** - The Datawave module and cable reels are furnished with casters to allow the unit to be rolled into place after it has been unbolted from the pallet.

**Check size and weight** - Refer to the cabinet drawings furnished with the unit for size and weight information. Typical cabinet dimensions and weights are shown in **Figure 1** and **Figure 2**.

**Plan the route** - The route that the Datawave module will follow to its installation area should be planned to ensure that all passages are large enough to accommodate the unit, and that the floors are adequate to support the weight. (i.e., Are the doorways, elevators, ramps, etc., adequate? Are there any non-negotiable corners or offsets in the hallways?)

**Move with care** - In order to prevent panel damage, it is recommended that the exterior panels be removed before the unit is moved. When replacing panels, remember to reconnect all panel ground wires.

**Close quarters?** - Removal of the side panels will aid in maneuvering the unit through close quarters. Removal of the side panels and brackets reduces the unit dimensions to:

	15-40 kVA	50-75 kVA
WIDTH	34 in. (864 mm)	42 in. (1,067 mm)
DEPTH	33.6 in. (854 mm)	31.6 in. (803 mm)

**Figure 1 Typical Cabinet and Floor Planning Dimensional Data, 15-30 kVA**

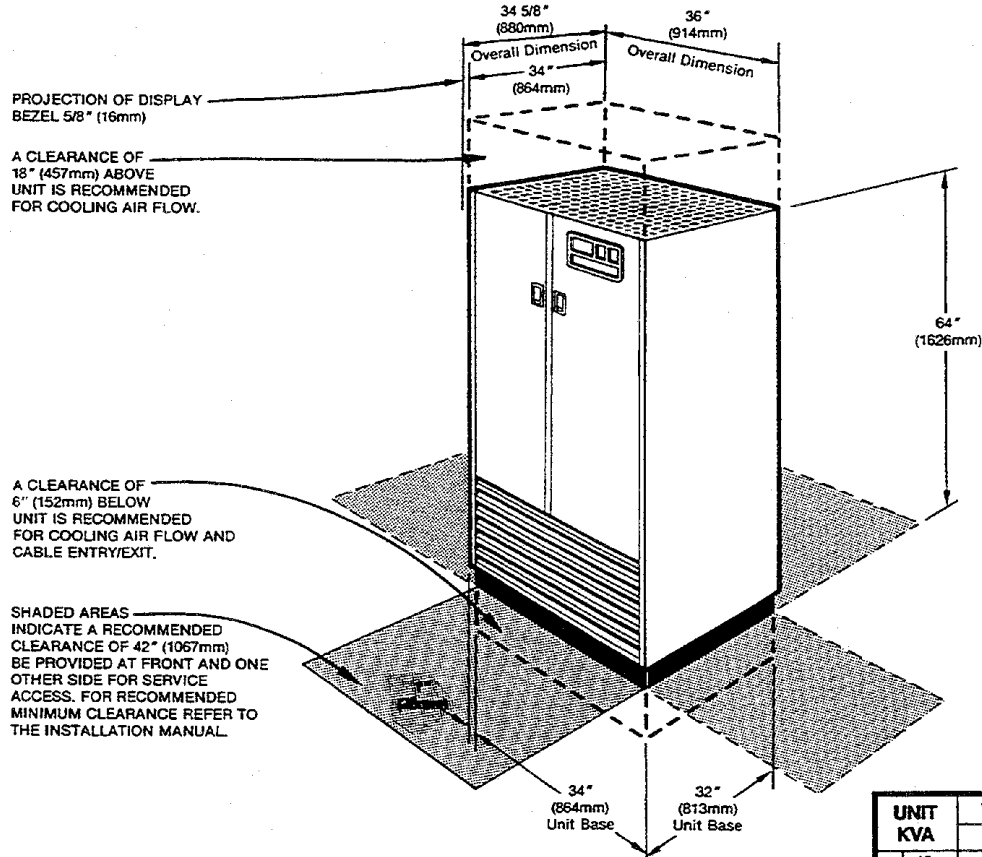

**CABINET DIMENSIONAL DATA**

UNIT KVA	WEIGHT - LBS (KG)	
	60 HZ	50 HZ
15	1200 (545)	1300 (590)
20	1500 (680)	1600 (730)
30	1600 (730)	1700 (775)

CUTOUT LOCATION FOR COOLING AIR FLOW.

CUTOUT LOCATION FOR CABLE ENTRY/EXIT.

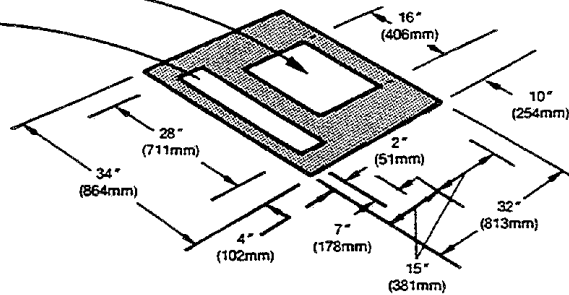

**FOOTPRINT AND FLOOR CUTOUT DIMENSIONS**

SEE SPECIFICATION SHEET FOR HEIGHT SUPPLIED. STANDARD HEIGHTS AVAILABLE FROM 6" (152mm) TO 18" (460mm).

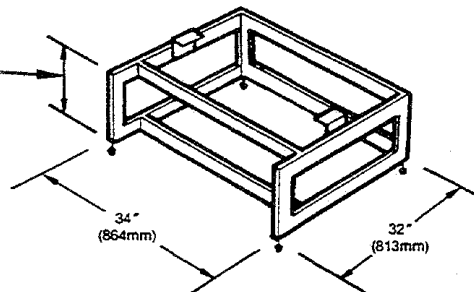

**OPTIONAL FLOORSTAND DIMENSIONAL DATA**

**Figure 2 Typical Cabinet and Floor Planning Dimensional Data, 50-75 kVA**

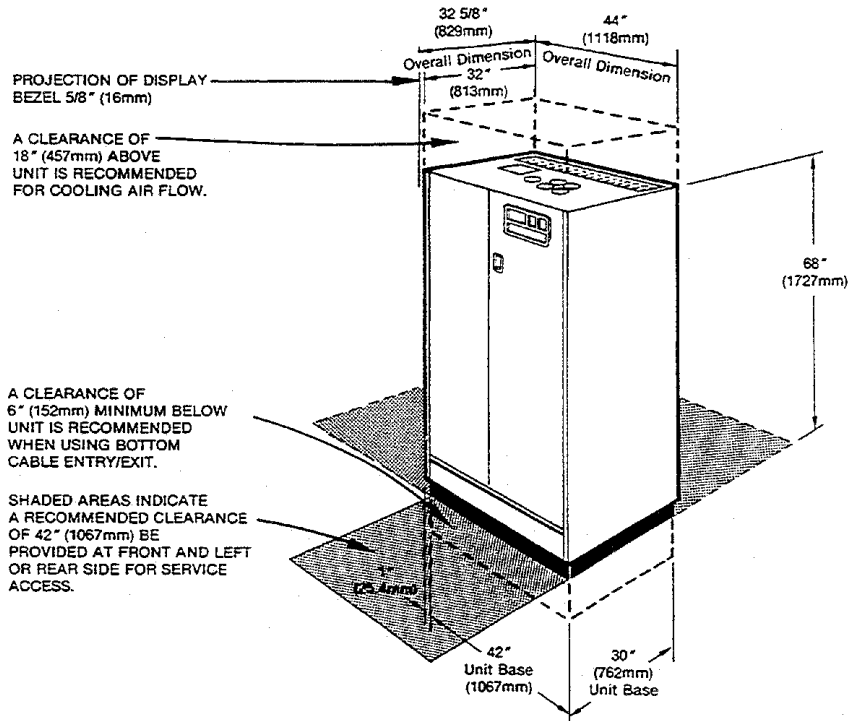

UNIT KVA	WEIGHT - LBS (KG)	
	60 HZ	50 HZ
50	2400 (1090)	2640 (1200)
75	2750 (1250)	3025 (1375)

**CABINET DIMENSIONAL DATA**

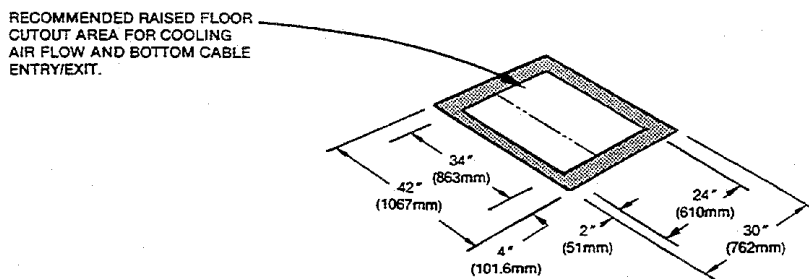

**FOOTPRINT AND FLOOR CUTOUT DIMENSIONS**

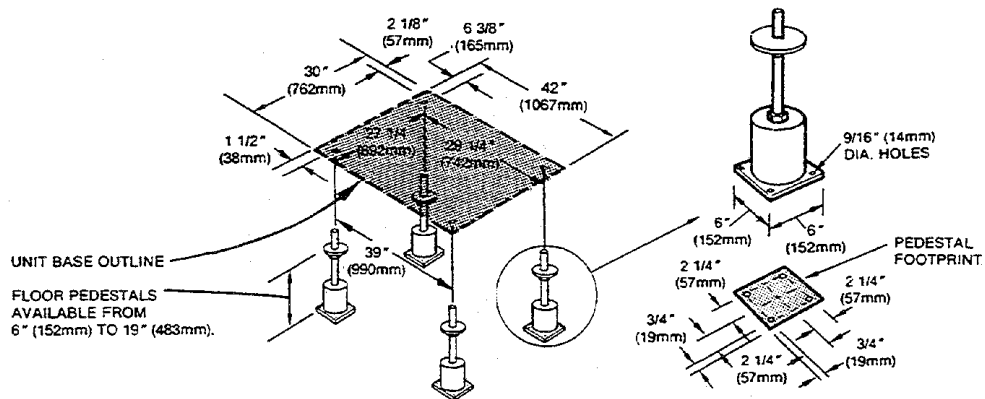

**OPTIONAL FLOOR PEDESTALS**

---

### 1.1.3 Unit Preparation

The Datawave unit may be easily removed from the shipping pallet and installed by customer personnel. A typical procedure is as follows:

1. Set the palletized assembly in a level area, where there is enough room to roll the unit and entire cable assembly off the pallet onto the floor.
2. Cut the shipping bands.



#### **WARNING**

**THE SHIPPING BANDS MAY BE UNDER TENSION. USE APPROPRIATE EYE, FACE, AND HAND PROTECTION TO SAFEGUARD AGAINST INJURY FROM BAND BACKLASH.**

3. Remove the Factory-provided ramp from its shipping position. (One ramp is provided per order, packed either in front of, or on top of, a set of cable reel(s).) Place the ramp adjacent to the pallet to provide a smooth path from pallet to floor.
4. Remove side and rear panels from the module. An allen wrench for the side panels is furnished in the installation packet. (Carefully disconnect panel ground wires by pulling the easy-disconnect terminals at the unit frame.)
5. Remove the bolts holding the unit to the shipping pallet. (Located in each of the four bottom corners.)
6. If cables are on wheeled cable reel(s), remove bolts holding reel(s) to pallet.
7. Remove shipping blocks from under unit and cable assembly, then remove chocks from all casters.
8. Roll unit off pallet onto floor, carefully guiding cable reel(s) after it.
9. Roll unit and cable package to location of installation. For units located on a raised floor, use care when positioning unit over the floor cutout to avoid casters falling through the cutout.



#### **CAUTION**

**Before maneuvering the unit into its final position, read and follow all advisories in the following “Location Considerations” paragraphs. For units without rear service access, perform the internal inspection as described in 2.0 - Equipment Inspection and Start-Up before maneuvering unit to its final position.**

### 1.1.4 Location Considerations

The Datawave system should be located close to the load(s) that it is supplying.

**Equipment Location** should employ the shortest output distribution cable runs consistent with logical equipment arrangement and allowances for future additions.

**Operating Environment** - Ambient temperatures of 0°C to 40°C with a relative humidity of 0% to 95% (non-condensing).

**Bottom Clearance** is required for exit of cables/ conduit and/or for cooling air flow. This clearance is automatically provided by a raised floor (6 inches / 150 mm minimum height). **Figure 1** and **Figure 2** show the typical raised-floor cutout dimensions.

When units are not located on a raised floor (or if the raised floor is not adequate to support the unit), optional floor pedestals may be used. (Non-raised floor applications are not CSA approved.)

**Recommended Minimum Service Clearances** are shown in **Figure 3**. The indicated clearances at the front and one other side or rear of the unit are required for service access by the National Electrical Code (NEC) (Article 110-16). Clearance above the unit is required for cooling air flow (exhaust).

**Audible Noise** - The average sound level output of the Datawave is 55 to 58 dBA at five feet (1.6 meters), which should be considered when determining unit location.

**Heat Output** - As all electrical devices, the Precision Power Center produces heat under normal operation. (See **Table 1.**) This heat output should be included when calculating the environmental conditions of the room.

**Altitude** - The Datawave system is designed for operation in altitudes up to 5000 feet (1500 meters) above sea level. For higher altitudes, contact the factory.

**Table 1 Heat Output**

Heat Output - BTU/Hr (kW)						
kVA/kW	Full Load		¾ Load		½ Load	
15/15	6,350	(1.85)	5,750	(1.68)	5,250	(1.54)
20/20	8,450	(2.47)	7,650	(2.24)	6,990	(2.05)
30/30	10,125	(2.97)	9,490	(2.78)	8,350	(2.44)
40/32	10,145	(3.16)	9,600	(2.82)	8,500	(2.50)
50/50	12,850	(3.76)	11,890	(3.48)	10,550	(3.09)
75/75	19,270	(5.65)	17,830	(5.23)	15,820	(4.63)

**Figure 3 Recommended Minimum Service and Ventilation Clearances**

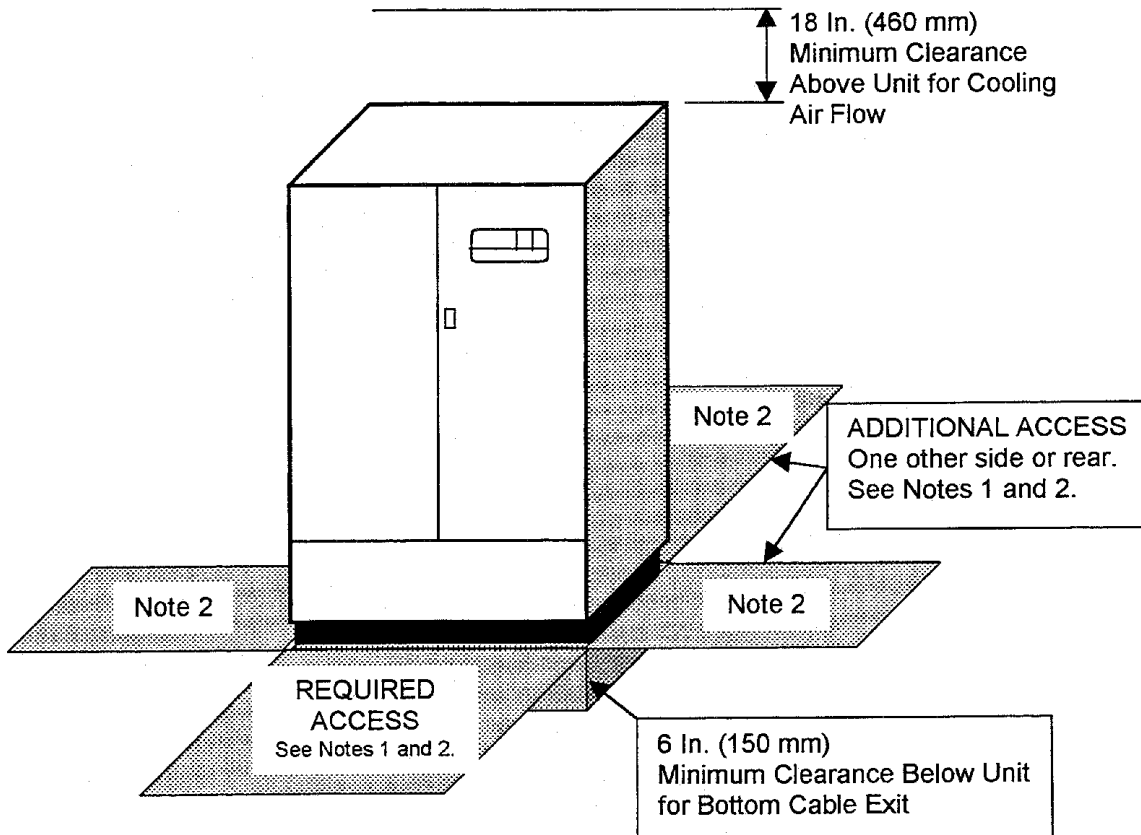

- NOTES:**
1. For 15-40 kVA units, required service access is the front plus one other side or rear. For 50-75 kVA units, minimum service access is the front and left side. Recommended service access is the front and rear.
  2. Service Access Clearance Dimensions:  
 36 in. (914 mm) for units up to 150 volts to ground.  
 42 in. (1067 mm) for units over 150 volts to ground.  
 44 in. (1118 mm) for rear clearance on 50-75 kVA units (if provided).

### 1.1.5 Floor Pedestal Installation (50-75 kVA Units)

Floor pedestals are optional equipment intended to provide clearance for bottom cable entry without relying on a raised floor to support the unit. The pedestals are adjustable over a limited range (approximately 3 1/2 inches) to allow leveling the unit and minor adjustments in the unit's installed height.



#### CAUTION

Floor pedestals may be reverse assembled for shipping. Before installation, the pedestals should be reassembled as shown in Figure 4. When the pedestal is properly assembled, the washer on top of the welded nut provides a bearing surface for the unit weight.

1. Insert the pedestal threaded shaft into the inside corner tubing of the cabinet base as shown in Figure 2.
2. Adjust the pedestal height by turning the welded nut/shaft assembly into or out of the pedestal base as required.
3. Lock the height by tightening the jam nut against the pedestal base.

The pedestal may be mounted to the floor by means of the four holes in the base. Locations of floor pedestals relative to the Datawave base outline are shown in Figure 2.

Figure 4 Floor Pedestal Details

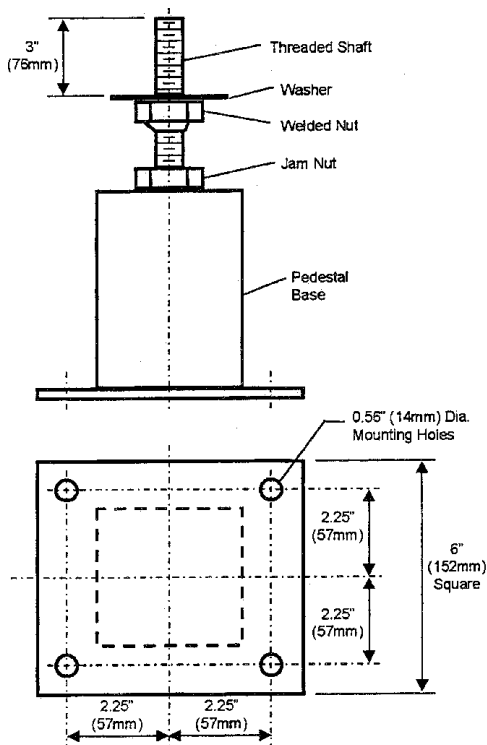

---

## 1.2 Power and Control Wiring

Power and control wiring should be installed by licensed electricians. All power and control wiring must comply with the NEC and applicable local codes.

### 1.2.1 Input Power Connections

If the Datawave Magnetic Synthesizer is furnished with junction boxes, input power connections are made as detailed in **1.2.2 - Junction Box Installation (if used)**.

If junction boxes are not furnished, the input power feeder is connected to the input power lugs or blocks located inside the unit. (See **Figure 5** and **Figure 6**.)



#### WARNING

**VERIFY THAT ALL INCOMING LINE VOLTAGE (POWER) AND LOW VOLTAGE (CONTROL) CIRCUITS ARE DE-ENERGIZED AND LOCKED OUT BEFORE INSTALLING CABLES OR MAKING CONNECTIONS, WHETHER IN THE JUNCTION BOX OR IN THE UNIT.**

**To minimize disturbances** caused by other loads in the building, the 3-phase power input to the Datawave should be supplied directly from the service entrance. However, if this is not possible, the Datawave's ability to isolate the sensitive load from power disturbances allows the system to work even without a dedicated power feeder.

**The input feeder circuit** should be sized in accordance with the NEC and any local building codes to assure the feeder's ability to safely carry the system's full load current, including losses.

**Input feeder conductors** should be sized for no more than 2% voltage drop. If operation at under-voltage conditions for extended periods of time is desired, the input feeders must be oversized.

**Typical conductor size data** is shown in **Table 2**. All connections must comply with the NEC and all other applicable codes.

**The main input feeder** should consist of 3-phase conductors and one (safety) ground conductor (3W + G) unless unit is equipped with a bypass option. (See Bypass Configurations, **Figure 7**.)

**For units with a bypass option without a bypass transformer**, the bypass input feeder must consist of 3-phase conductors, one neutral (if required by the load), and one (safety) ground conductor (4W + G).

**Bypass option** - Typical configuration diagrams for the bypass option are shown in **Figure 7**. An external bypass transformer may be required if Datawave input voltage is different from output voltage. Power terminals are provided inside the unit for connections to the bypass transformer.

When the input voltage level matches the rated output voltage level and a bypass transformer is not used, jumpers must be added to the bypass transformer terminal block input to output. Be sure to observe proper phase rotation.

**Bypass Transformer Connections** - Input connections to the bypass transformer should be 3-phase, 3-wire plus ground (3W + G), sized the same as the Datawave input wiring. Output connections from the transformer should be 3-phase, 4-wire plus ground (4W + G), sized for the full load output of the Datawave. If the bypass transformer is located farther than 10 feet (3 meters) from the Datawave, additional overcurrent protection for the output wiring from the transformer may be required to meet electrical codes.

**Any alternate energy source**, such as a diesel-generator, powering the Datawave should be equipped with an isochronous governor to ensure proper regulation of the frequency. Typical computer loads specify a frequency range of  $\pm 0.5$  Hertz.

**Figure 5 Electrical Field Connection Locations, Self-Contained (SC) 15-30 kVA Units**

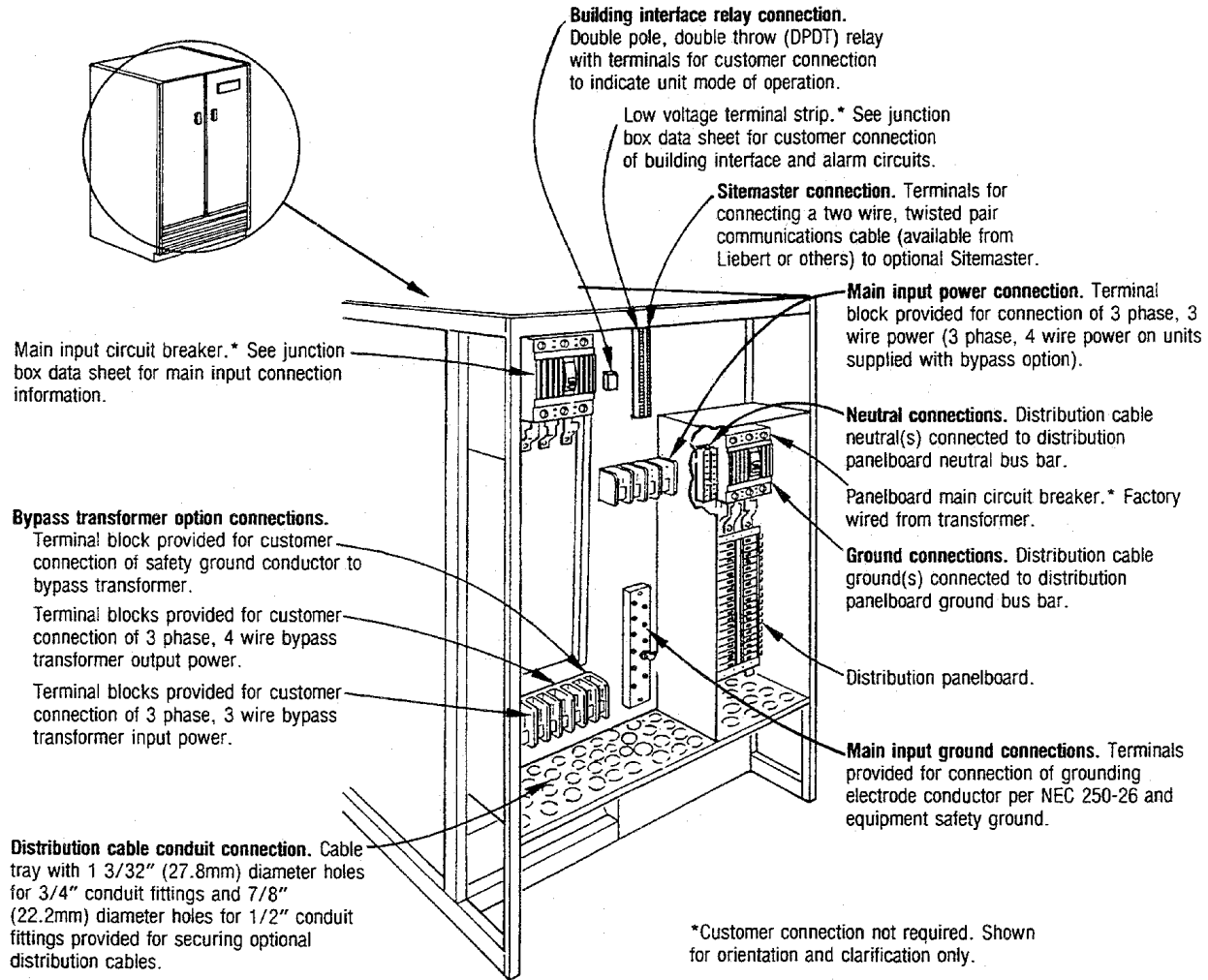

**FRONT VIEW WITH PANELS REMOVED**

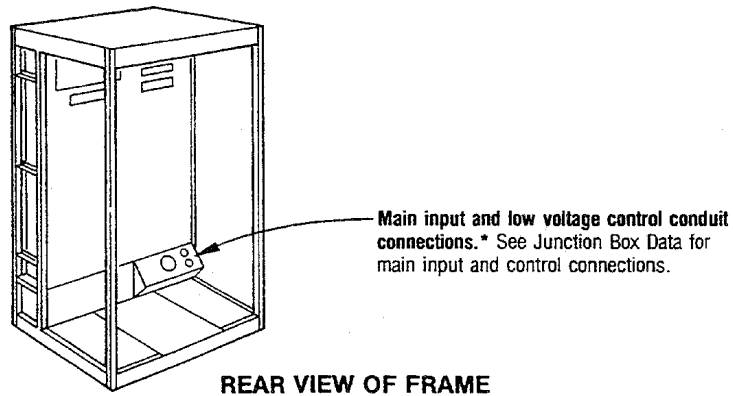

**REAR VIEW OF FRAME**

**Figure 6 Electrical Field Connection Locations, Conditioning Alone (CA) 15-30 kVA Units**

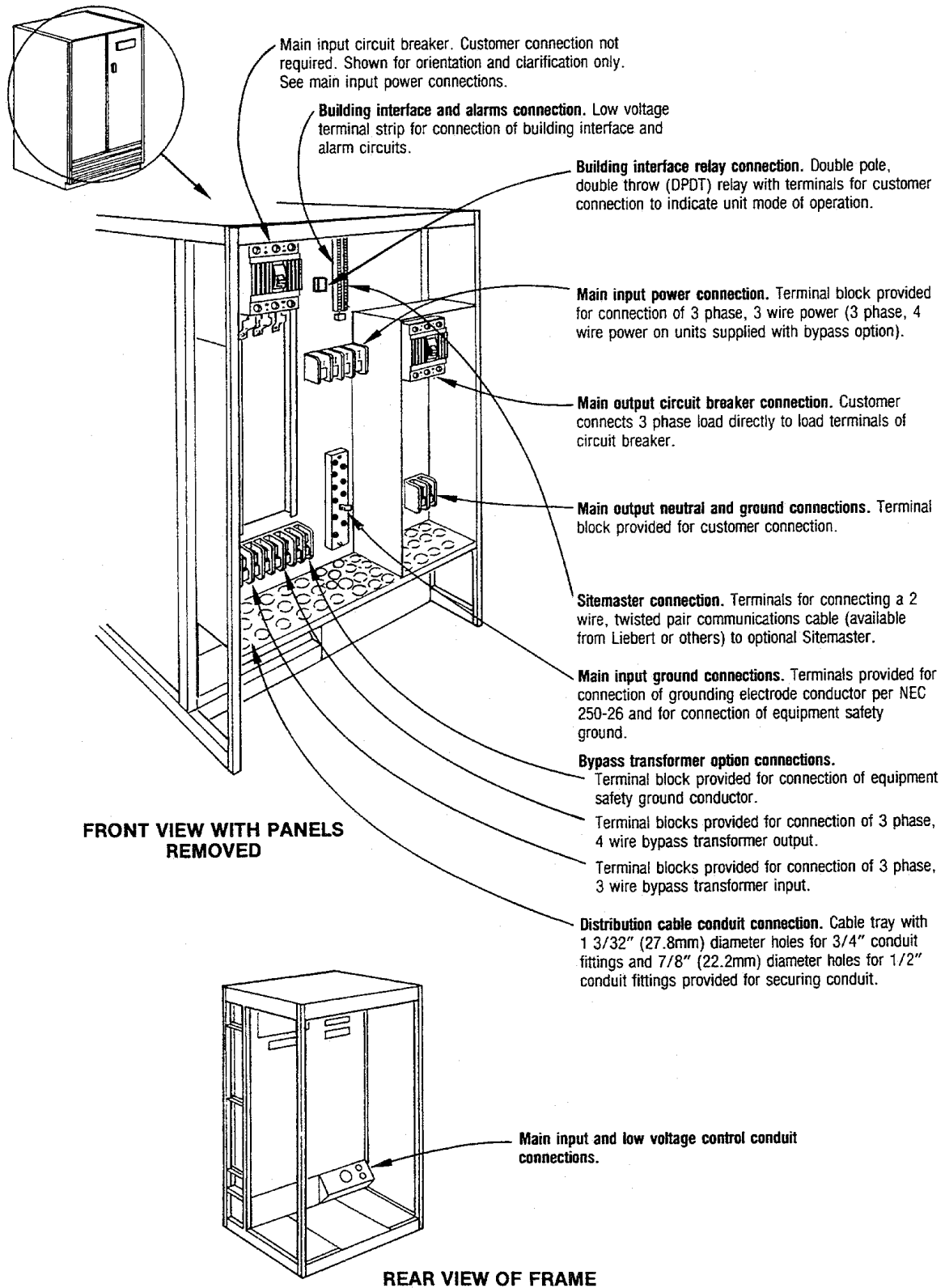

**Figure 7 Electrical Field Connection Locations, Self-Contained (SC) 50-75 kVA Units**

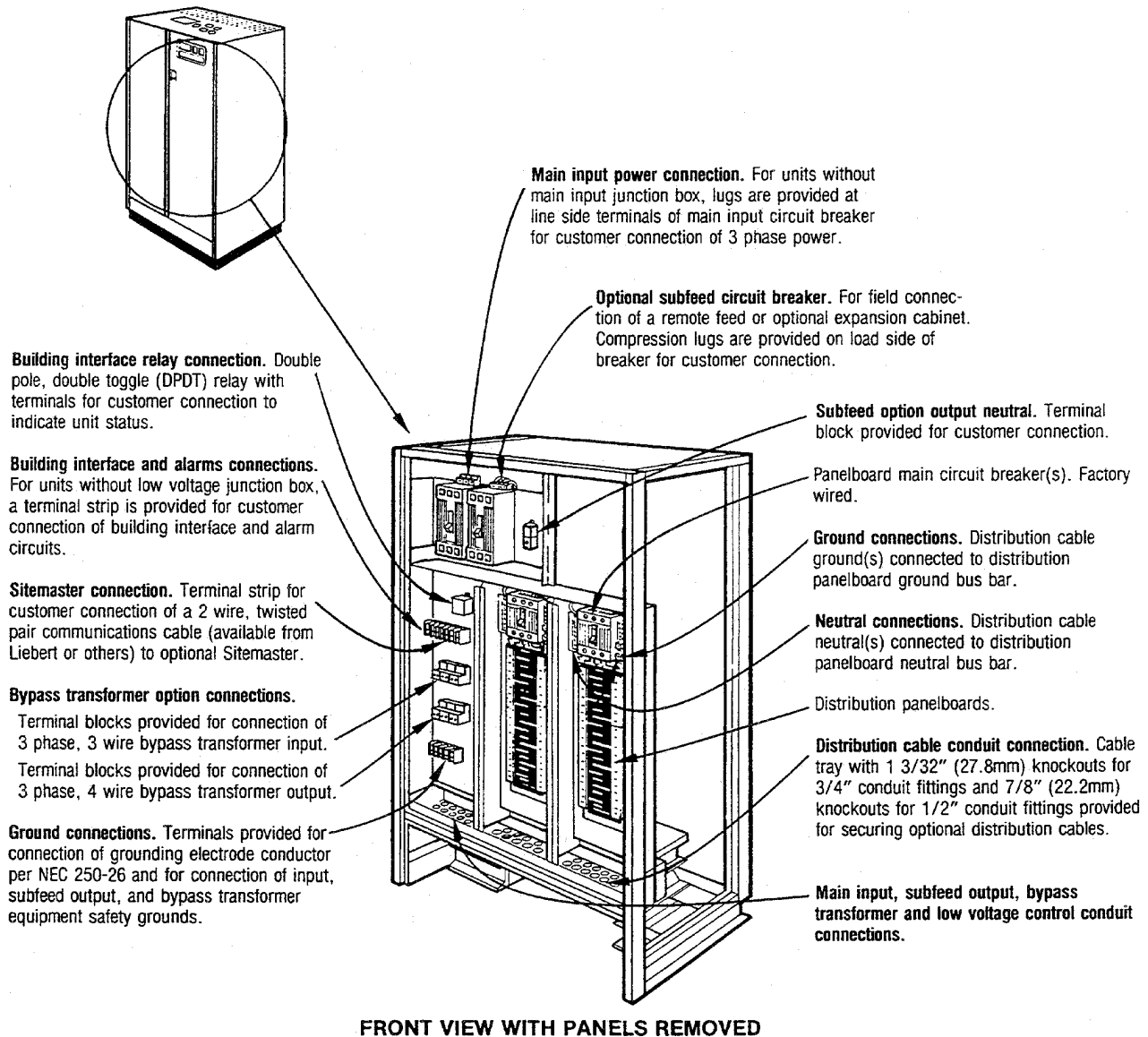

**Figure 8 Electrical Field Connection Locations, Conditioning Alone (CA) 50-75 kVA Units**

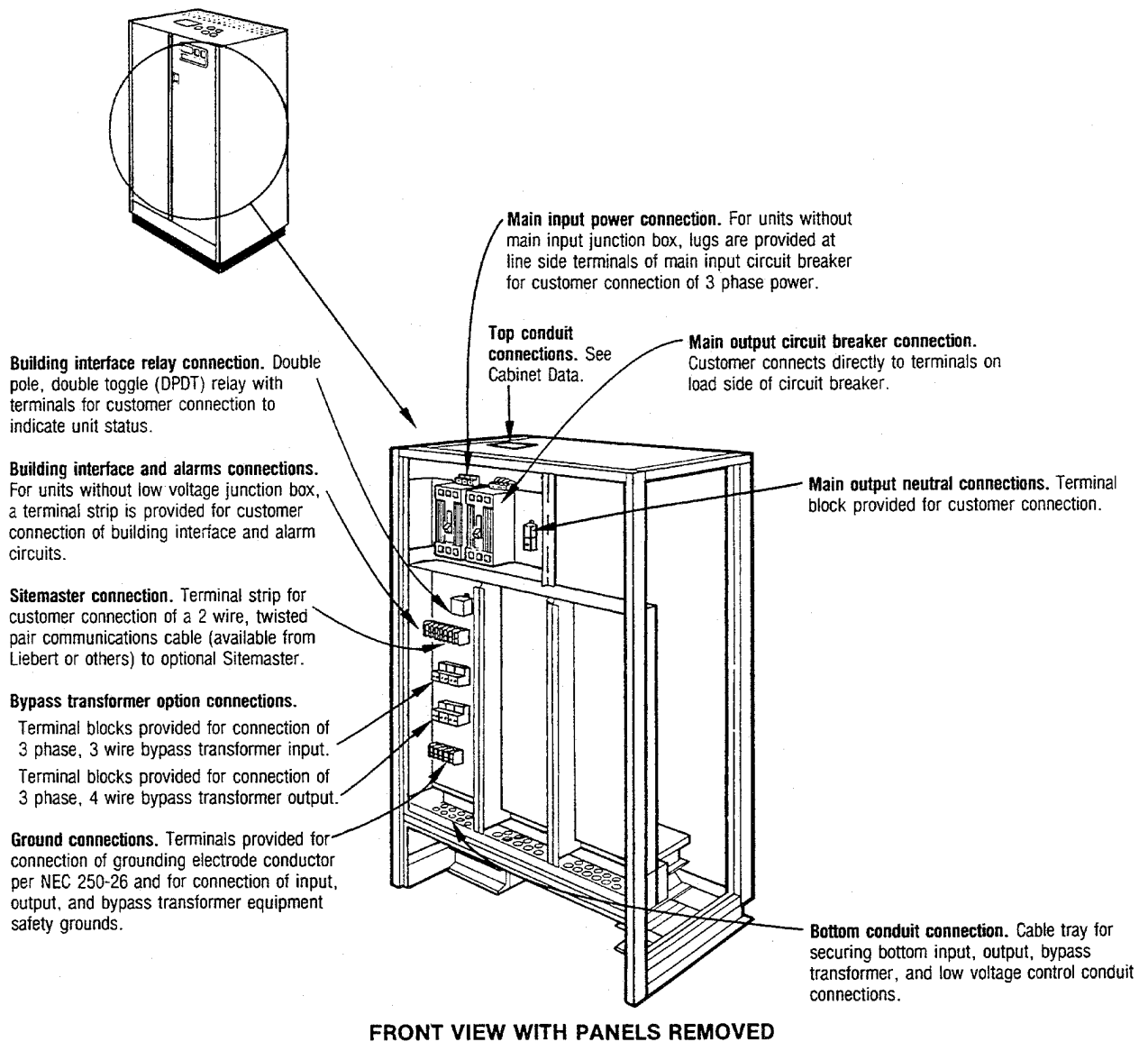
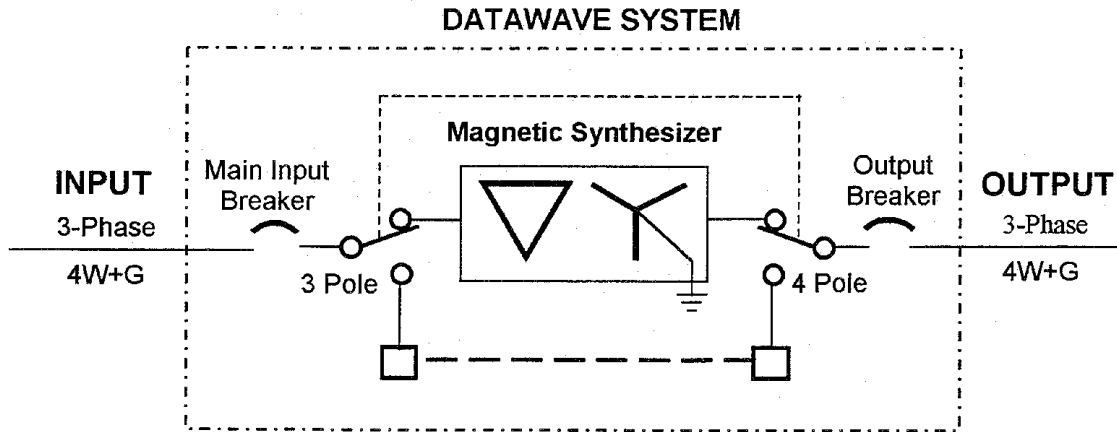
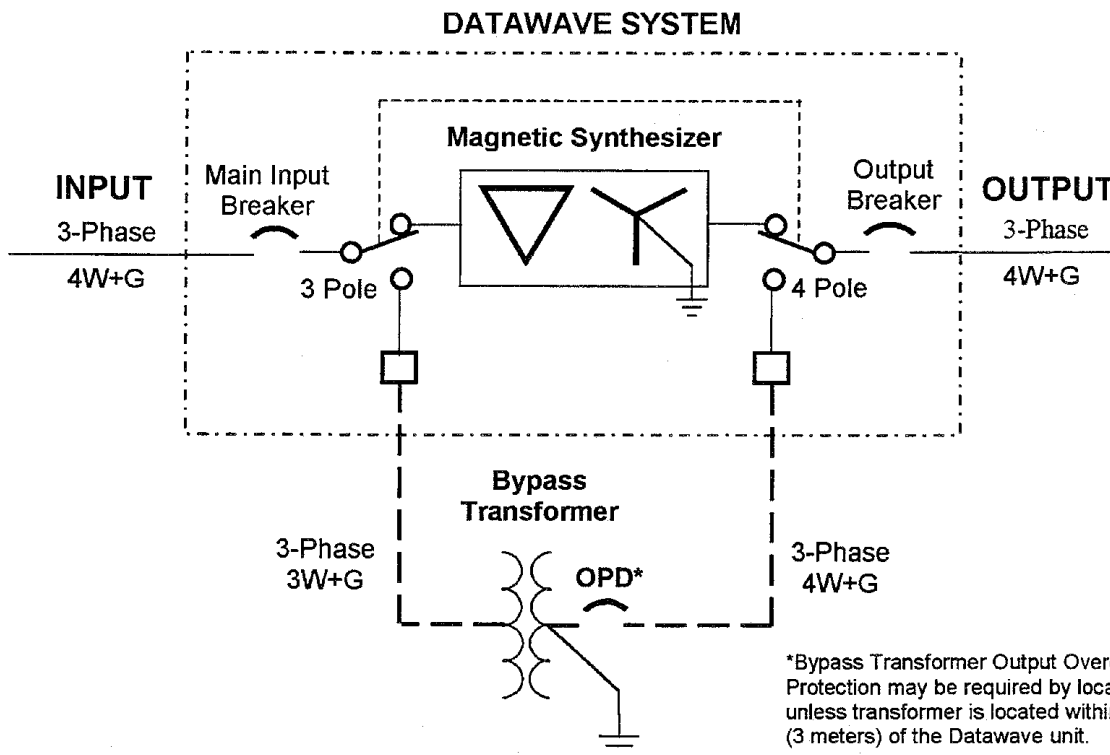

Figure 9 Datawave Bypass Configuration



NOTE: For Input and Output Breaker sizes see Table 2.

**BYPASS CONFIGURATION WHEN NOMINAL INPUT VOLTAGE LEVEL MATCHES DATAWAVE OUTPUT VOLTAGE**



\*Bypass Transformer Output Overcurrent Protection may be required by local codes unless transformer is located within 10 feet (3 meters) of the Datawave unit.

NOTE: For Input and Output Breaker sizes see Table 2.

**BYPASS CONFIGURATION WHEN NOMINAL INPUT VOLTAGE LEVEL DOES NOT MATCH DATAWAVE OUTPUT VOLTAGE**

**Table 2 Suggested Minimum Wire Size**

VOLTAGE	kVA kW	MAIN INPUT <sup>1</sup>			OUTPUT		
		FLA	OPD	Suggested feeder wire size <sup>2</sup> (AWG)	FLA	OPD <sup>3</sup>	Suggested feeder wire size <sup>4</sup> (AWG)
208V	15	49	60	6	42	60	6
	20	65	80	4	56	70	4
	30	95	125	1	83	110	2
	40/32	100	125	1	111	150	0
	50	155	200	000	139	175	00
	75	233	300	350 kcmil	208	300	350 kcmil
240V	15	42	60	6	—	—	—
	20	56	70	4	—	—	—
	30	83	100	2	—	—	—
	50	135	175	00	—	—	—
	75	202	250	250 kcmil	—	—	—
380V	15	27	40	8	23	30	10
	20	36	50	8	30	40	8
	30	52	70	4	46	60	6
	50	85	110	2	76	100	3
	75	127	175	00	114	150	0
400V	15	25	40	8	22	30	10
	20	34	50	8	29	40	8
	30	50	70	4	43	60	6
	50	81	110	2	72	90	3
	75	121	175	00	108	150	0
415V	15	24	30	10	21	30	10
	20	33	40	8	28	40	8
	30	48	60	6	42	60	6
	50	78	100	3	70	90	3
	75	117	150	0	104	150	0
480V	15	21	30	10	18	25	10
	20	28	40	8	24	30	10
	30	41	50	8	36	50	8
	40/32	52	70	4	58	70	4
	50	67	90	3	60	80	4
	75	101	125	1	90	125	1
600V	15	17	25	10	14	20	12
	20	22	30	10	19	25	10
	30	33	50	8	29	40	8
	50	54	70	4	48	60	6
	75	81	110	2	72	90	3

**FLA** = Full Load Amps of Datawave Magnetic Synthesizer

**OPD** = Overcurrent Protection Device inside Datawave Magnetic Synthesizer

Wire Sizes based on NEC 1996 Table 310-16, using 75°C copper conductor.

- Main input power feeder** should be dedicated feeder direct from service entrance if possible. Ground conductors recommended to be insulated conductors run with power conductors for increased system performance. Ground conductor minimum size per NEC Table 250-95. Input power feeder conduit may be used as the safety ground conductor. When conduit is used, adequate electrical continuity must be maintained at conduit connections to enclosures and throughout conduit run.
- Input feeder wire size** listed in **Table 2** is the minimum feeder size recommended. Larger wire size may be required because of voltage drop or supply overcurrent protection device.
- Output OPD's** listed in **Table 2** are the standard sizes for Model CA only. See the unit's specification sheet.
- Output feeder wire size** listed in **Table 2** is the minimum feeder size recommended. Larger wire size may be required because of voltage drop or excessive neutral current (see NEC Table 310-16 notes 8 and 10). For best performance, Synthesizer should be located as close to the load as practical.

## 1.2.2 Junction Box Installation (if used)

Main input (power) and low voltage (control) junction boxes are available for the 15 through 75 kVA Datawave Magnetic Synthesizer to simplify customer connections.

**Shipping Arrangements** - The junction boxes, if used, can either be shipped with the system or can be advanced-shipped for installation during the roughing-in stage of new construction.

**Installation Location** - 10 foot (3 meters) long flexible cables are supplied by the factory for connecting the junction boxes to the unit. The junction boxes should be installed a maximum of 8 feet (2.4 meters) from the feeder entrance of the Datawave.

It is recommended that the junction boxes be centered under an easily removable floor tile.

Junction Box Connections must be installed in compliance with the NEC and all other applicable codes.



### WARNING

**VERIFY THAT INCOMING LINE VOLTAGE (POWER) AND LOW-VOLTAGE (CONTROL) CIRCUITS ARE DE-ENERGIZED AND LOCKED OUT BEFORE INSTALLING CABLES OR MAKING ANY CONNECTIONS IN THE JUNCTION BOX.**

Typical junction box connections are shown in **Figure 8** and described in **1.2.1 - Input Power Connections** and **1.2.6 - Control Wiring Connections**.

**Dimensions** - Dimensions are given on the drawings furnished with the unit. Typical dimensions of the junction boxes are as follows:

#### Low Voltage (Control) Junction Box:

Width	8 in. (203 mm)
Length	10 in. (245 mm)
Height	4 in. (102 mm)

#### Main Input (Power) Junction Box:

Dimension in inches (mm)

	Input Voltage		
	208-240	380-415	480-600
<b>15-40 kVA</b>			
Width	14 (356)	14 (356)	14 (356)
Length	16 (406)	16 (406)	16 (406)
Height	6 (152)	6 (152)	6 (152)
<b>50 kVA</b>			
Width	16 (406)	14 (356)	14 (356)
Length	30 (762)	16 (406)	16 (406)
Height	6 (152)	6 (152)	6 (152)
<b>75 kVA</b>			
Width	16 (406)	16 (406)	14 (356)
Length	30 (762)	30 (762)	16 (406)
Height	6 (152)	6 (152)	6 (152)

**Table 3 Main Input Circuit Breaker Lug Size and Interrupting Rating**

OPD	Lug Size <sup>1</sup> (Copper Conductor)	Interrupting Rating <sup>2</sup>			
		208 V	480 V	380-415 V	600 V
Up to 110 AMPS	#14 - #3/0 AWG	65 kA	25 kA	15 kA	18 kA
Up to 250 AMPS	#6 AWG 0 350 kcmil	65 kA	25 kA	25 kA	18 kA
300 to 400 AMPS	(2) #2/0 - 400 kcmil	65 kA	35 kA	25 kA	25 kA

1. Applies to units without input junction box.

2. Standard Rating. See Unit's Specification Sheet for other ratings.

Figure 10 Typical Junction Box Connections

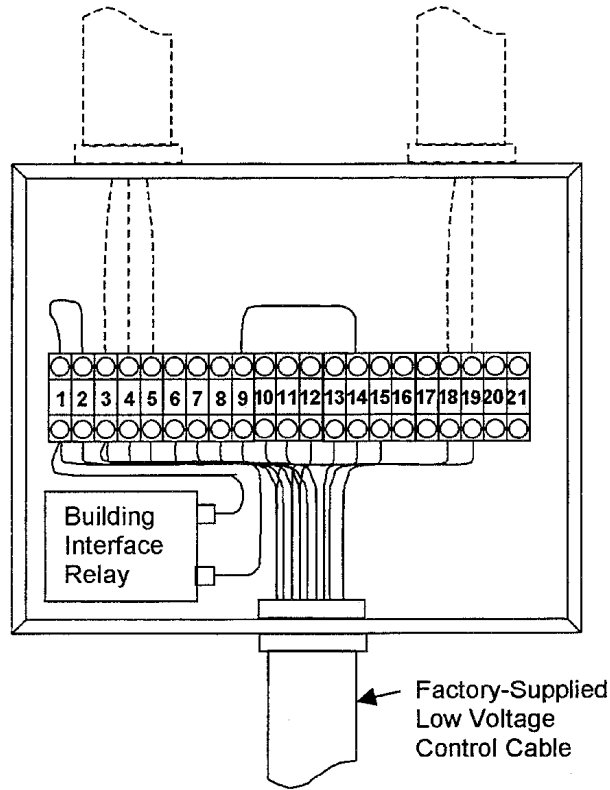

Low Voltage Control Junction Box

**Customer Input Power Connection**  
3 Phase 3W+G or 3 Phase 4W+G.  
See input power connections section.

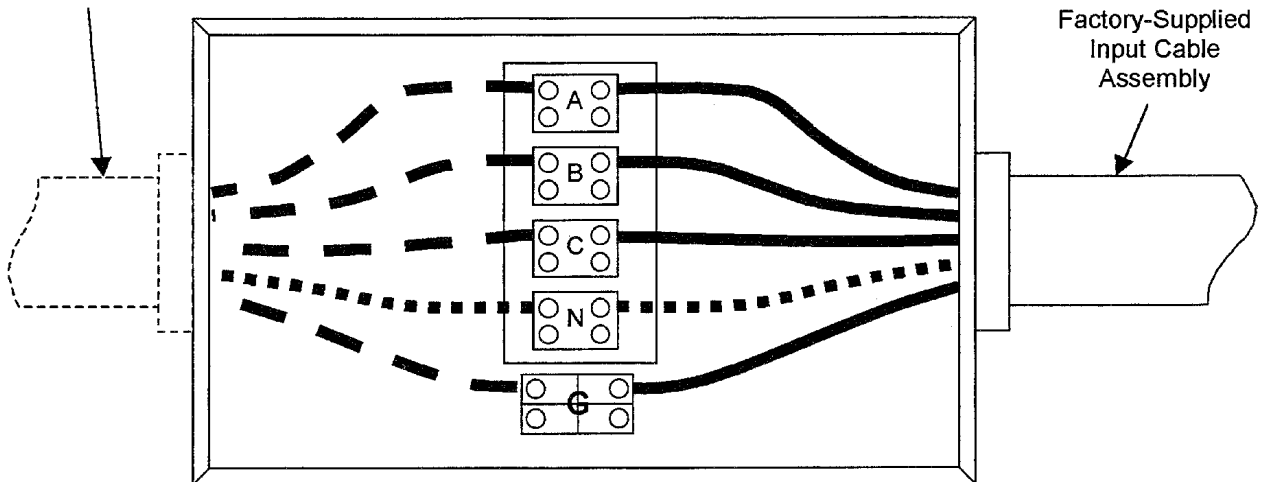

Main Input and Bypass Input Junction Box

### 1.2.3 System Grounding

The performance and safety of any power conditioning system depends upon proper grounding. **Figure 9** shows a typical grounding arrangement for the Datawave system.

**Equipment grounding** - Grounding is primarily for safety. Correct implementation of grounding also enhances equipment performance. All power feeders must include equipment grounding means as required by the NEC and local codes.

An insulated ground conductor is recommended to be run in each feeder conduit. Although ground conductors can be the minimum size per NEC Table 250-95, larger wire size may be used for increased system performance. If the input power feeder conduit is used as a grounding conductor, adequate electrical continued must be maintained at all conduit connections.

Using isolating bushings in a metal conduit run can be a safety hazard and is not recommended.

**Signal reference grid** - If the Datawave is used to supply power to a computer room or area which is equipped with a signal reference grid or a grounded raised-floor stinger system, a grounding conductor should be connected from the Datawave system ground bus to the grid or floor system. This conductor should be #8 AWG or larger, and as short as practical. Less than 3 feet (1 meter) is recommended.

### 1.2.4 Grounding Electrode Conductor

**Required by code** - The Datawave Magnetic Synthesizer should be grounded according to the safety practices of NEC 250-96. A local grounding electrode conductor is recommended in addition to the equipment safety ground that is normally run with the input power conductors.

**Unit connection** - As shown in **Figure 9**, the grounding electrode conductor is run from the Datawave to the *nearest effectively grounded* (in order of preference):

1. Building steel
2. Metal water pipe
3. Other made grounding electrode

**Sizing** of the grounding electrode conductor is based on the secondary circuit conductors. According to the NEC (Table 250-94), the minimum recommended grounding electrode conductor is shown in **Table 4**.

**Table 4** Grounding Electrode Size

Minimum Grounding Electrode Conductor (AWG) (Based on 75°C Copper Conductors)					
kVA	Output Voltage				
	208 V	380 V	415 V	480 V	575 V
15-30	8	8	8	8	8
40	6	8	8	8	8
50	4	8	8	8	8
75	2	6	6	6	6

**Recommended methods for running the grounding electrode conductor** (arranged in order of preference for system performance, as acceptable by local and other applicable codes):

1. Outside of conduit (where not susceptible to damage)
2. Inside non-metallic conduit
3. Inside non-ferrous conduit
4. Inside ferrous conduit *bonding to the ferrous conduit at both ends*, as acceptable by local and other applicable codes

Figure 11 Typical Datawave Grounding Arrangement

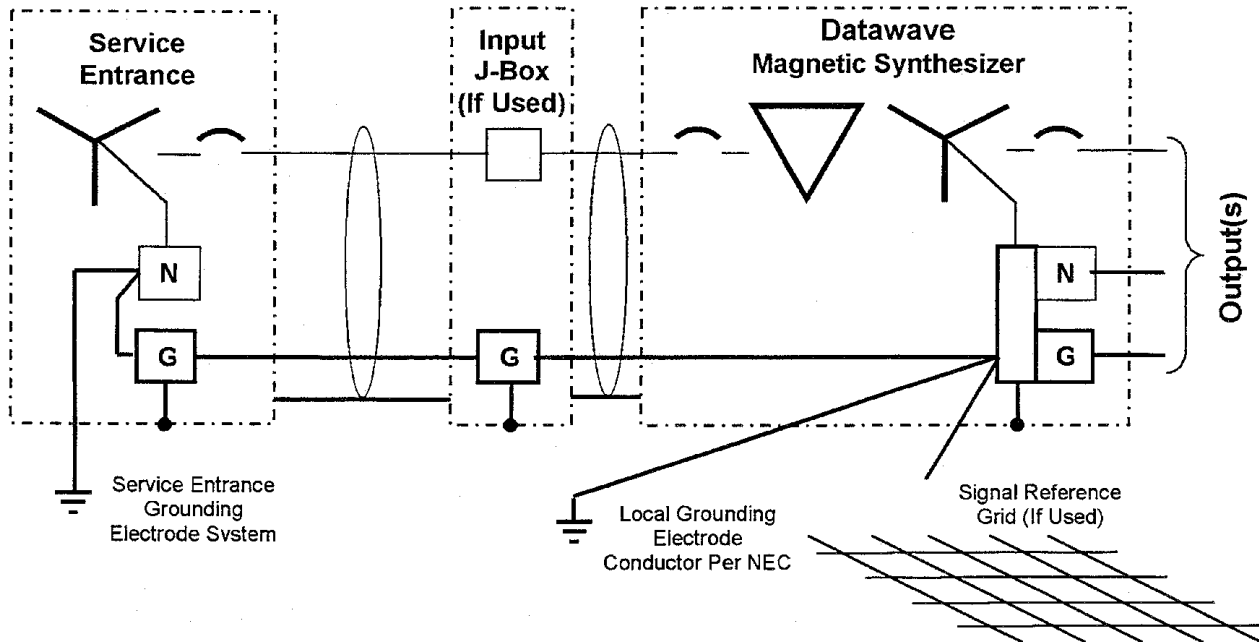

### 1.2.5 Output Power Connections



**WARNING**

**VERIFY THAT INCOMING LINE VOLTAGE CIRCUITS ARE DE-ENERGIZED AND LOCKED OUT BEFORE INSTALLING OUTPUT BREAKERS AND CABLES.**

**Code Compliance** - All output cables and connections must comply with the NEC and all other applicable codes.

When equipped with integral distribution, the Datawave provides the flexibility of custom output power distribution configuration.

**Output circuit breaker(s) and/or panelboards** with ground and neutral provisions are provided inside the Datawave unit for connecting load(s) as required. (See **Figure 6** and **Figure 7**.)

**Flexible output distribution cables** for use in data processing areas under a raised floor are optional and may be factory supplied. Cable lengths and layout should be well-planned.

**Cable access** - Cable routes should follow aisles between equipment. This will facilitate access to cables for installation, routine inspection, and future changes.

**Cable length** - Measure the distance to the load equipment following right-angle paths, rather than diagonally or directly. Always measure to the extreme far side of the equipment with respect to the Datawave unit to insure adequate cable length.

**Air circulation** - Prevent restriction of airflow under the raised floor by running the flexible conduits flat on the sub-floor, in parallel paths.

**Padlock-off provisions** - All output cables without receptacles which are hard-wired to the load equipment must be equipped with a padlock-off accessory for the output circuit breaker. The padlock-off accessory is to be used to lock-out and tag the circuit breaker when service is performed on the hard-wired load equipment in accordance with OSHA safety rules.

**The main output feeder** for Conditioning Alone units should be sized for no more than 2% voltage drop. Typical conductor-size data is shown in **Table 2**, however, larger wire size may be required because of voltage drop or excessive neutral harmonic currents. (See the NEC, table 310-6, notes 8 and 10.) For best performance, the Datawave should be located as close to the load as practical.

**Initial system output loading** should be between 50% and 75% of rated capacity. This allows the addition of future loads without immediately investing in another power conditioner.

For additional information on calculating the required system capacity, see Liebert Powerline PLT-09, *Power Calculations (System Sizing)*.

Keep the load balanced. Although the Datawave Magnetic synthesizer can tolerate up to a 100% load imbalance, balancing of loads is good design practice on any 3-phase system. Accordingly, each Datawave distribution panel is load-balanced at the factory, based on output branch circuit breaker sizes. All additions to the system should be arranged so as to preserve this balance.

### 1.2.6 Control Wiring Connections

All Liebert power conditioning systems have provision for external shutdown control from Remote Emergency Power Off (REPO) stations. **Figure 10** is a simplified diagram of the shutdown circuitry of the Datawave Magnetic Synthesizer.

**Low-voltage control circuit** - As shown in **Figure 10**, the control circuit operates on 24Vdc. The shutdown device (represented by the REPO switch) activates a low-current 25Vdc relay which in turn operates the shunt-trip mechanism. The shunt-trip solenoid opens the Main Input breaker, which de-energizes the power center.

**Multiple-unit shutdown.** When more than one unit is installed by the user, a typical requirement is that actuation of a single device (REPO for example) must shut down all power centers. The low-voltage control circuits of all modules of any standard Liebert Datawave system are designed to meet this requirement.

**Detailed diagrams and descriptions** of the shutdown schemes for multiple-system installations are contained in the Liebert Power Line PLT-35, "Multiple Power Center Control Schemes."

**External control wiring connections** for Remote Shutdown, alarm, and/or monitoring are made to the low-voltage junction box (if used) or to the low-voltage control terminal strip located inside the Datawave Unit.

Control wiring connections vary with the type of monitoring system furnished with the unit. Three typical control wiring configurations are shown in **Figure 11** and **Figure 12**.

**Code Compliance** - Control wiring connections must comply with the NEC and all other applicable codes.



#### WARNING

**VERIFY THAT ALL INCOMING LINE VOLTAGE (POWER) AND LOW VOLTAGE (CONTROL) CIRCUITS ARE DE-ENERGIZED AND LOCKED OUT BEFORE INSTALLING CABLES OR MAKING CONNECTIONS, WHETHER IN THE JUNCTION BOX OR IN THE UNIT.**

Figure 12 Simplified Shutdown Circuit

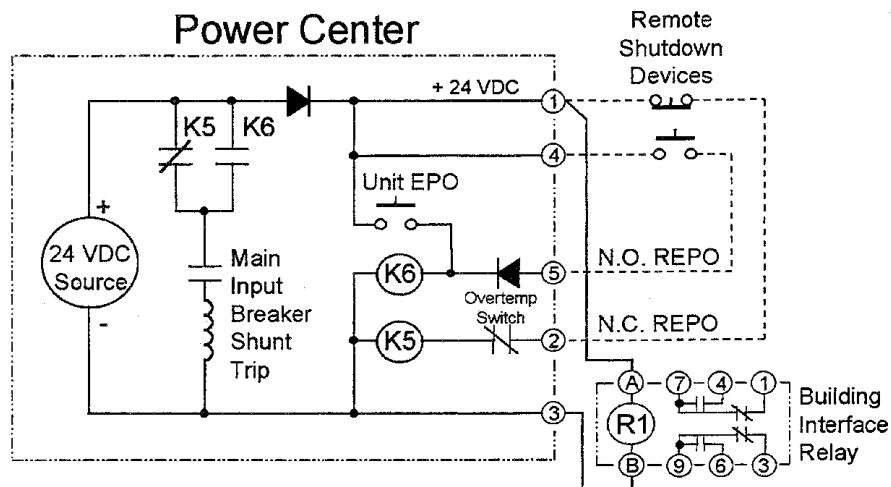
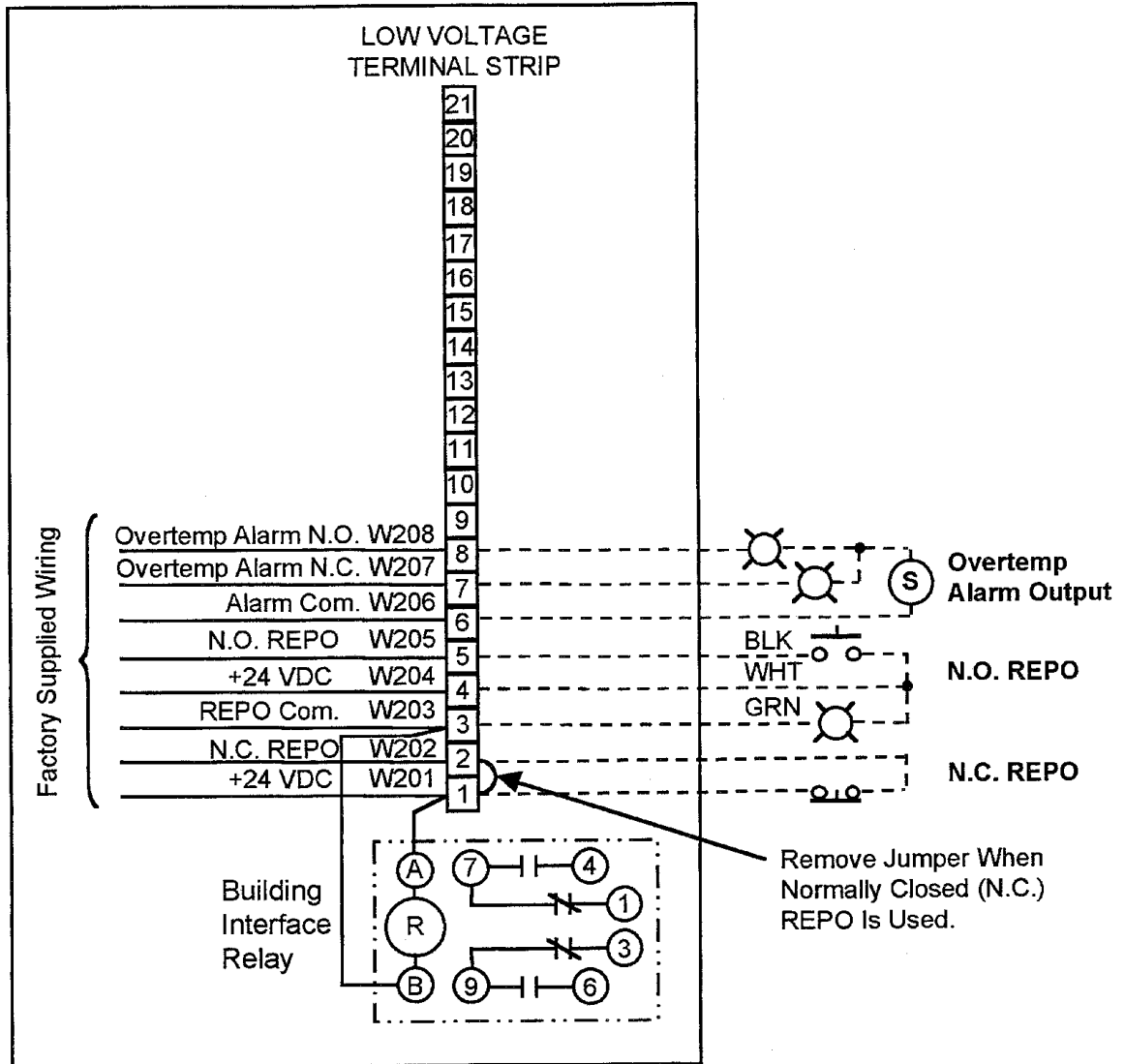

Figure 13 Typical Control Wiring for Units Without Monitoring



**NOTES**

1. Building Interface Relay can be used for remote shutdown or alarm. Relay is energized during normal operation. DPDT contacts rated ¼ HP at 120 VAC, 10A at 28 VDC or 240 VAC.
2. Other N.O. REPO devices may be wired in parallel to the N.O. REPO contacts. Other N.C. REPO devices may be wired in series to the N.C. REPO contacts. Multiple REPO lamps and other 24 VDC loads may be wired in parallel to the REPO lamps. Max. 24 VDC supply available is 1 Amp total. Both N.O. and N.C. REPO switches are powered from the same supply.
3. All Auxiliary Control Devices and Cabling to be Field Supplied except as noted.
4. Overtemp Alarm contacts change state when unit overtemperature is sensed.

Figure 14 Typical Control Wiring for Units With Power Monitoring

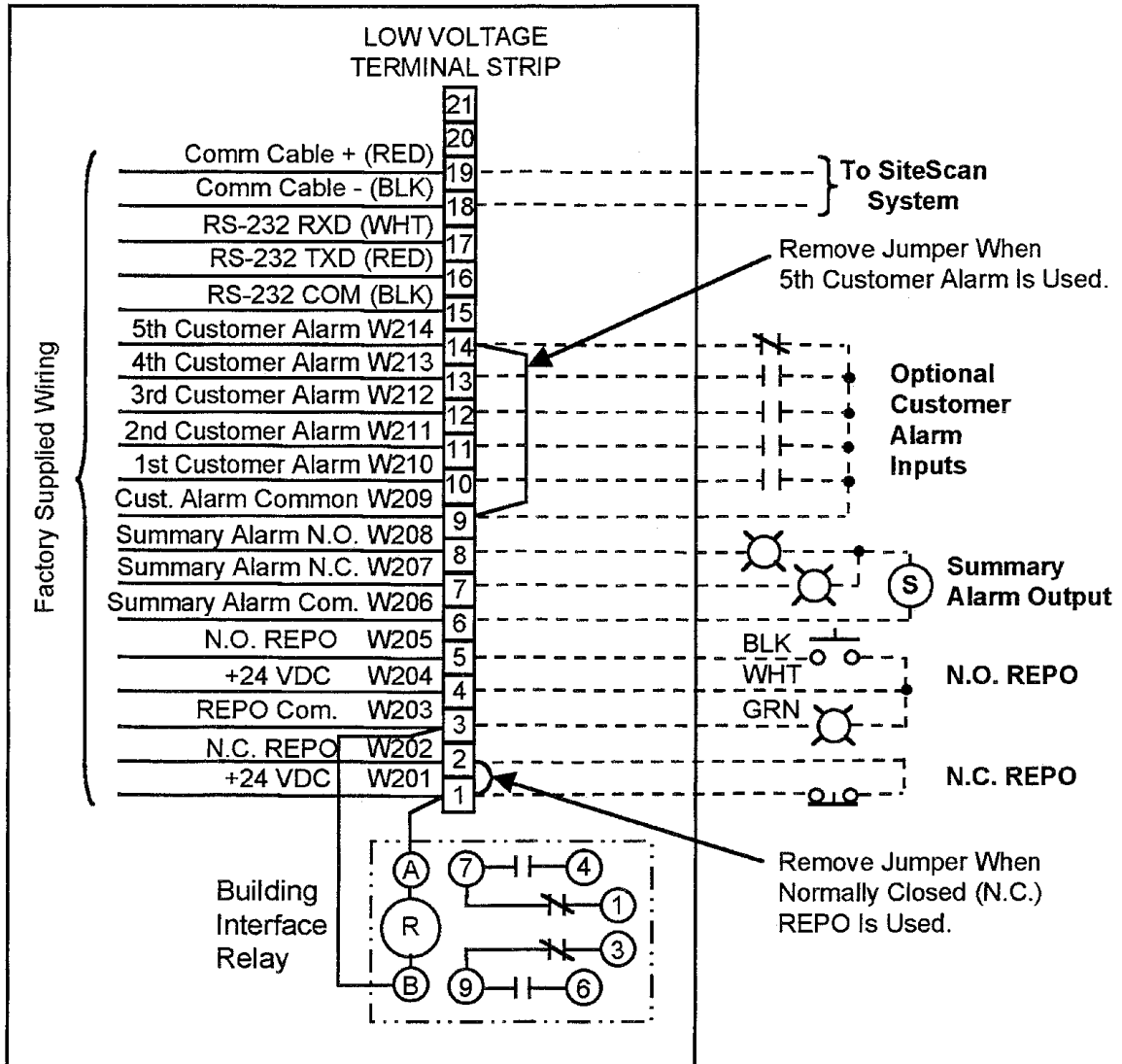

NOTES

1. Building Interface Relay can be used for remote shutdown or alarm. Relay is energized during normal operation. DPDT contacts rated ¼ HP at 120 VAC, 10A at 28 VDC or 240 VAC.
2. Other N.O. REPO devices may be wired in parallel to the N.O. REPO contacts. Other N.C. REPO devices may be wired in series to the N.C. REPO contacts. Multiple REPO lamps and other 24 VDC loads may be wired in parallel to the REPO lamps. Max. 24 VDC supply available is 1 Amp total. Both N.O. and N.C. REPO switches are powered from the same supply.
3. All Auxiliary Control Devices and Cabling to be Field Supplied except as noted.
4. Overtemp Alarm contacts change state when unit overtemperature is sensed.
5. RS-232 Port connected to low voltage terminal strip inside unit. Connect using suitable 300V communication cable.

---

## 2.0 EQUIPMENT INSPECTION AND START-UP

---

### 2.1 Internal Inspection

A detailed internal inspection should be performed after the unit is in place and before it is energized, to ensure trouble-free start-up. The same internal inspection should be carried out when performing preventive maintenance.



#### WARNING

**VERIFY THAT ALL INCOMING POWER AND CONTROL CIRCUITS ARE DE-ENERGIZED AND LOCKED OUT BEFORE PERFORMING THE INTERNAL INSPECTION.**

**Open the unit** - Gain access to the internal components of the Datawave unit by removing the exterior panels.

**Visually inspect** - Be sure wiring and components are not damaged. Check capacitors for oil leaks or bulging.

**Check power connections** - Check all power connections for tightness. Refer to **Table 5** for torque requirements of all electrical connections.

**Perform formal detailed inspection** - follow the procedures described in **3.0 - Inspection and Start-Up Checklist** when performing detailed inspection.

### 2.2 Start-Up

**Checklists** - Follow the detailed the step-by-step checklist (**3.0 - Inspection and Start-Up Checklist**) when installing and starting-up the Datawave Magnetic Synthesizer.

**Initial system start-up** - a qualified electrician should be employed to perform the equipment inspection and start-up. Liebert system start-up may be arranged by calling your local Liebert sales representative or Liebert Global Services. In the USA call **1-800-543-2378**.

**Warranty effectivity** - A copy of the appropriate checklist (furnished with the equipment) must be completed, signed, dated and returned to the Factory. **Warranty coverage of the equipment is not effective unless the Checklist is received by the Factory.**



#### WARNING

**EQUIPMENT INSPECTION AND START-UP SHOULD BE PERFORMED ONLY BY TRAINED PERSONNEL.**

**HAZARDOUS VOLTAGES ARE PRESENT DURING START-UP PROCEDURES.**

**ELECTRICAL SAFETY PRECAUTIONS MUST BE FOLLOWED THROUGHOUT INSPECTION AND START-UP.**

**Table 5 Torque Specifications (Unless Otherwise Labeled)**

<b>A. Nut and Bolt Combinations</b>				
<b>Bolt Shaft Size</b>	<b>Grade 2 Standard</b>		<b>Electrical Connections with Belleville Washers</b>	
	<b>lb-in</b>	<b>N-m</b>	<b>lb-in</b>	<b>N-m</b>
1/4	53	6.0	46	5.2
5/16	107	12.1	60	6.8
3/8	192	21.7	95	10.7
1/2	528	60.0	256	28.9

<b>B. Main Input and Main Output Circuit Breakers</b>			
<b>Breaker Size</b>	<b>Wire Size</b>	<b>Compression Lug</b>	
		<b>lb-in</b>	<b>N-m</b>
Up to 110 Amp	#14 - #10	35	4.0
	#8 - #3	100	11.4
	#2 - #3/0	150	17.1
125 to 250 Amp	#3 - #1	200	22.8
	#1/0 - 350 kcmil	275	31.3
300 to 600 Amp	#2 - 600 kcmil	375	42.7

<b>C. Panelboard Main Circuit Breaker</b>		
	<b>lb-in</b>	<b>N-m</b>
Busbar-to-Breaker	90	10.2
Compression Lug	250	28.5

<b>D. Branch Circuit Breakers</b>		
	<b>lb-in</b>	<b>N-m</b>
Up to 30 Amp	35	4.0
40 to 100 Amp	45	5.1

<b>E. Terminal Block Compression Lug</b>		
<b>AWG Wire Size or Range</b>	<b>lb-in</b>	<b>N-m</b>
#14 - #10	35	4.0
#8	40	4.5
#6 - #00	120	13.6
#6 - 350 kcmil	275	31.1
#4 - 500 kcmil	375	42.4

---

## 3.0 INSPECTION AND START-UP CHECKLIST

---

Unit Serial Number: \_\_\_\_\_

Unit Model Number: \_\_\_\_\_

Date: \_\_\_\_\_

### 3.1 Inspection



#### WARNING

**ALL EQUIPMENT INSPECTION PROCEDURES ARE TO BE PERFORMED WITH POWER TO THE UNIT TURNED OFF AND LOCKED OUT.**

#### Exterior Inspection

- \_\_\_ 1. Confirm that the exterior of unit is undamaged (including cables and receptacles, if furnished).
- \_\_\_ 2. Confirm that service and ventilation clearances are adequate (See Installation Manual Figure 1-3).

#### Interior Inspection

- \_\_\_ 3. Remove accessible exterior panels.



#### NOTE

*When removing exterior panels, DISCONNECT PANEL GROUND WIRES BY SEPARATING THE EASY-DISCONNECT TERMINALS LOCATED ON THE FRAME. When replacing exterior panels, reconnect all panel ground wires.*

- \_\_\_ 4. Inspect all wire and conductor insulation for damage.
- \_\_\_ 5. Inspect all wiring connections to the capacitor banks. Re-secure the connections if necessary. Remove capacitor tray retaining screws which prevent trays from sliding during shipping.
- \_\_\_ 6. Check all transformer terminal connections for tightness. Retorque if necessary.
- \_\_\_ 7. Check all terminal mounting bolts for tightness. Retorque if necessary.
- \_\_\_ 8. Check transformer mounting bolts for tightness. Retorque if necessary.
- \_\_\_ 9. Remove any foreign objects from the components or the interior area of the unit. **Make sure air passages on transformers are clear and free of debris.**
- \_\_\_ 10. Check that the cooling fan blades move freely, and that the intake and exhaust air screens are clean and free of obstructions.
- \_\_\_ 11. Replace side panels, leaving access to circuit breakers for the following start-up procedure.



#### NOTE

*When replacing the side panels, be sure to reconnect the panel ground wires.*

---

## 3.2 Start-Up



### WARNING

**START-UP PROCEDURES SHOULD BE PERFORMED ONLY BY QUALIFIED PERSONNEL. HAZARDOUS VOLTAGES ARE PRESENT IN THE EQUIPMENT THROUGHOUT THE MAJORITY OF THE START-UP PROCEDURE. PROCEED WITH CAUTION.**

- \_\_\_ 12. Make certain that **all** circuit breakers are in the OFF position and that all power to the unit is locked out.
- \_\_\_ 13. Place BYPASS Switch (if provided) in the “NORMAL” position.



### NOTE

*Steps 14 through 17 apply to the Main Input Junction Box. If this installation is not provided with a Main Input Junction Box, proceed directly to Step 19.*

- \_\_\_ 14. Remove the cover of the Main Input Junction Box. Verify proper input power connections to unit, including equipment grounding conductor.
- \_\_\_ 15. Turn ON the building power to the junction box. Check the phase rotation at the junction box. Phase rotation should be A, B, C, as indicated.
- \_\_\_ 16. Check and record the input voltages at the junction box:  
**Volts, phase A to phase B = \_\_\_\_\_**  
**Volts, phase B to phase C = \_\_\_\_\_**  
**Volts, phase C to phase A = \_\_\_\_\_**
- \_\_\_ 17. Turn OFF and lock out the building power to the input junction box.
- \_\_\_ 18. Replace the junction box cover.
- \_\_\_ 19. Verify proper input power connections to unit, including equipment grounding conductor and local grounding electrode conductor.
- \_\_\_ 20. Turn ON the building input power to the unit.
- \_\_\_ 21. Check the phase rotation at the main input breaker. Phase rotation should be A, B, C, left-to-right.
- \_\_\_ 22. Check and record the input voltages at the main input breaker. Measured voltages should correspond to the unit’s nameplate input voltage.  
**Volts, phase A to phase B = \_\_\_\_\_**  
**Volts, phase B to phase C = \_\_\_\_\_**  
**Volts, phase C to phase A = \_\_\_\_\_**
- \_\_\_ 23. Turn ON the main input breaker; wait one minute. (If breaker trips OFF, check for wiring errors including control connections. Contact Liebert Global Services or the local factory representative for assistance.)
- \_\_\_ 24. Check the phase rotation at the line side terminals (top) of the output circuit breaker(s). The rotation should be A, B, C, left-to-right.

- 
- \_\_\_ 25. Check and record the voltages at the line-side terminals of the output circuit breaker. Measured voltages should correspond to the unit's nameplate output voltage (within +4%, -0%).

**Volts, phase A to phase B** = \_\_\_\_\_

**Volts, phase B to phase C** = \_\_\_\_\_

**Volts, phase C to phase A** = \_\_\_\_\_

**Volts, phase A to neutral** = \_\_\_\_\_

**Volts, phase B to neutral** = \_\_\_\_\_

**Volts, phase C to neutral** = \_\_\_\_\_

Measure and record the initial capacitor currents according to **5.3 - Datawave Magnetic Synthesizer Check**.

If output voltages or capacitor currents are incorrect, check for wiring errors. Contact Liebert Global Services. In the USA call 1-800-543-2378 or contact your factory representative for assistance.

- \_\_\_ 26. Verify that all internal cooling fans are operating.
- \_\_\_ 27. Depress the local EMERGENCY POWER OFF switch and verify system shutdown. Turn the unit back on.
- \_\_\_ 28. Repeat Step 27 for each remote EMERGENCY POWER OFF switch with which the system is equipped.

Note that the remote EMERGENCY POWER OFF switch may shutdown more equipment than just the Datawave unit.



**NOTE**

*Steps 29 through 34 apply to the optional Bypass Switch. If the system is not equipped with a bypass switch, proceed directly to Step 35.*

- \_\_\_ 29. Turn the bypass switch to "AUXILIARY" position.
- \_\_\_ 30. If bypass transformer is required, verify proper bypass power connections to unit, including neutral and equipment grounding conductor. (See Installation Manual Figure 1-7).
- \_\_\_ 31. Turn ON the unit main input breaker.
- \_\_\_ 32. Check the phase rotation at the line side of the output breaker(s). The rotation should be A, B, C, left-to-right.
- \_\_\_ 33. Check and record the voltages at the line-side terminals of the output circuit breaker:
- \_\_\_ 34. Turn off all breakers. Return Bypass switch to "NORMAL" position.

**Volts, phase A to phase B** = \_\_\_\_\_

**Volts, phase B to phase C** = \_\_\_\_\_

**Volts, phase C to phase A** = \_\_\_\_\_

**Volts, phase A to neutral** = \_\_\_\_\_

**Volts, phase B to neutral** = \_\_\_\_\_

**Volts, phase C to neutral** = \_\_\_\_\_



**NOTE**

*The voltages in Step 34 should not differ significantly from those recorded in Step 25. If there is more than a 3% variation, turn OFF the building power to the unit, then verify proper tap settings of the bypass transformer (or the building distribution transformer if there is no bypass transformer). Then repeat Steps 31 through 34.*

- \_\_\_ 35. Turn off all breakers. Return Bypass switch to "NORMAL" position.

---

### 3.3 Monitoring System Check Out

- \_\_\_ 36. **BASIC INDICATORS, Main Input:**
  - \_\_\_ a. With the bypass switch in NORMAL position, turn the building power to the main input ON, then turn the main input breaker ON.
  - \_\_\_ b. Check that the local EMERGENCY POWER OFF button is illuminated and that the second indicator (TRANSFORMER OVERTEMP or ALARM PRESENT) is off.
  - \_\_\_ c. Return all breakers to OFF.
- \_\_\_ 37. **BASIC INDICATORS, Bypass Input. If unit has Bypass option:**
  - \_\_\_ a. With the bypass switch in AUXILIARY position, turn the building input power ON, then turn the main input breaker ON.
  - \_\_\_ b. Check that the local EMERGENCY POWER OFF button is illuminated and that the TRANSFORMER OVERTEMP is off. **(If “UNIT IN BYPASS MODE” is alarmed, the ALARM PRESENT indicator should be ON.)**
  - \_\_\_ c. Return all breakers to OFF and bypass switch to NORMAL position.
- \_\_\_ 38. **MANUAL RESTART CHECK. If unit is equipped with Manual Restart:**
  - \_\_\_ a. Turn on building power to the Main input. Turn Main Input breaker ON.
  - \_\_\_ b. Turn off all building power to unit.
  - \_\_\_ c. Observe that Main Input breaker automatically trips open upon power loss.
  - \_\_\_ d. Restore main input building power and return Main Input breaker to ON.
- \_\_\_ 39. **POWER MONITOR PANEL. If unit is equipped with a Power Monitor Panel:**

Turn the unit ON. Ensure that the voltage values indicated by the Monitor Panel correspond to the voltage values measured at the input and output circuit breaker (Steps 22 and 25).
- \_\_\_ 40. **CENTRALIZED MONITORING.**

**If the unit is connected to a Centralized Monitoring system:** Turn the unit and Centralized Monitoring System ON. Verify proper monitor system operation.
- \_\_\_ 41. **CONTROL VOLTAGE:**
  - \_\_\_ a. Obtain access to the low voltage terminals in the Low Voltage Junction Box (if used), or in the low voltage control section inside unit.
  - \_\_\_ b. Turn the unit ON. Measure and record the control voltage on terminals 1 (+) and 3 (COM).
  - \_\_\_ c. **Control voltage** = \_\_\_\_\_  
(Voltage should be between 20 and 28 Vdc.)
- \_\_\_ 42. **CUSTOMER ALARMS. If customer alarms are provided:**
  - \_\_\_ a. Turn the unit ON and simulate alarm operation by jumpering the appropriate low voltage control terminals. (Refer to the control wiring installation drawing furnished with the unit.)
  - \_\_\_ b. Verify correct alarm annunciation by the Power Monitor Panel and/or by the Centralized Monitoring System.

---

### 3.4 Equipment Connection Check Out (For Units With Distribution Cables)



#### CAUTION

All loads should be disconnected or turned off before proceeding with the following steps.

For units with output distribution cables, be sure that there are **NO** output receptacles connected to load equipment plugs, and that the receptacles are not in contact with foreign objects.

Pay special attention to those output cables intended for direct-wiring connection; the exposed conductor ends of these cables must not be in contact with each other or with any foreign objects.

- \_\_\_ 43. With Bypass switch in the NORMAL position, turn on min input power to unit, then turn on the panelboard main output breaker(s).
- \_\_\_ 44. Individually turn on each branch circuit breaker and check the output voltage (also phase rotation, if a 3-phase circuit) at the receptacle or cable end.
- \_\_\_ 45. Turn OFF all branch circuit breakers and the panelboard main output circuit breaker(s).
- \_\_\_ 46. Connect the load equipment per equipment manufacturer's specification and recommendations.
- \_\_\_ 47. Turn the panelboard main output breaker(s).
- \_\_\_ 48. Turn on branch circuit breakers to the load equipment. **Observe the power-up sequence recommended by the equipment manufacturer.**
- \_\_\_ 49. Verify that all load equipment operates properly.
- \_\_\_ 50. Replace all unit panels.

After Inspection and Start-Up procedure is complete, the completed Start-Up & Inspection form furnished with the unit should be signed and returned to:

Liebert Corporation  
12050 Dearborn Drive  
P.O. Box 29186  
Columbus, Ohio 43229



#### NOTE

*Warranty is not in effect unless Inspection and Start-Up form is received by the factory.*

---

## 4.0 OPERATING INSTRUCTIONS

---

### 4.1 Start-Up Procedures

Before unit is placed into service after initial installation, after equipment relocation, or after equipment has been de-energized for an extended period of time, perform equipment inspection and start-up procedures as detailed in **2.0 - Equipment Inspection and Start-Up** and **3.0 - Inspection and Start-Up Checklist**.

After initial system start-up, the following guidelines can be used for standard equipment operation. These guidelines should be reviewed for any special equipment modifications, special site considerations, or company policies that may require changes to the standard equipment operation.

#### 4.1.1 Emergency Shutdown

**To perform an immediate system shutdown** during emergency conditions, lift the protective clear cover and push the “Emergency Power Off” (EPO) switch located on the unit front door.



#### NOTE

*Depending on the particular control circuit wiring operation of the unit EPO switch may cause other equipment to also shutdown.*

*If site is equipped with a Remote Emergency Power Off (REPO) switch (such as is required by NEC Article 645 at the principal exit doors), to perform an immediate room (system) shutdown, activate one of the REPO switches.*

#### 4.1.2 Normal System Shutdown

**To perform a normal system shutdown**, perform an orderly load equipment (computer system) shutdown according to the load equipment manufacturer’s recommended shutdown sequence. The load equipment can be turned **OFF** at each piece of load equipment or at the distribution (circuit breaker) panels. Turn **OFF** all unit output breakers, then turn **OFF** the unit’s main input circuit breaker. To remove all power from the unit, turn **OFF** the building power to the unit’s input breaker or junction box.

#### 4.1.3 Normal System Turn ON

**Make certain all unit circuit breakers are in the OFF position.** All unit circuit breakers are located behind the front doors. Turn **ON** building power to the unit. Turn **ON** the unit’s main input circuit breaker. If the circuit breaker has been tripped **OFF** (instead of being turned **OFF**), the circuit breaker handle must be moved to the **OFF** position before being turned **ON**. If the unit has a voltage monitoring panel, verify proper output voltages before turning **ON** output circuit breakers. Turn **ON** the panelboard main breakers. Individually turn **ON** each output circuit breaker following the load equipment manufacturer’s start-up sequence.

#### 4.1.4 Manual Restart

If unit’s manual restart feature has been selected, the unit’s main input circuit breaker will be tripped upon a power outage, preventing repetitive application of unstable voltage and allowing for an orderly system restart. If the main input circuit breaker is tripped upon a power outage after power is restored, follow the **Normal System Turn ON** outlined above.

## 4.2 Basic Monitor Panel (Units Without Monitoring)

**XFORMER OVER TEMP/SILENCE** - Upon occurrence of a transformer overtemperature condition, the “Xformer Over Temp/Silence” switch will become illuminated and the audible alarm will be activated. Pushing the “Xformer Over Temp/Silence” switch will silence the audible alarm. The cause of the overtemperature condition should be investigated and corrected. Possible causes include unit overload, excessive non-linear loading, inadequate ventilation, high or low input voltage, or monitoring malfunction. Failure to correct the overtemperature condition may result in an automatic system shutdown due to the second stage of overtemperature sensing. After correction of the alarm condition, the alarm will automatically reset.

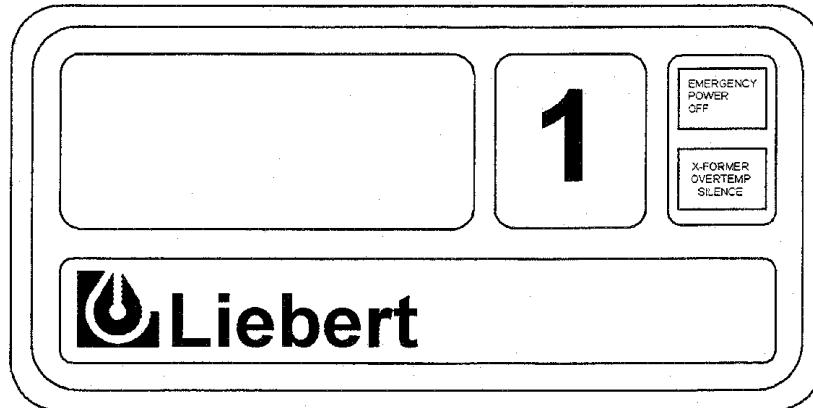

## 4.3 Power Monitor Panel

**Monitored Parameters** - A 4 x 20 character LCD display is provided to indicate the input voltages (line-to-line), output voltages (line-to-line and line-to-neutral), output currents (each phase, neutral and ground), output voltage THD, output current THD, crest factor, K-factor, output kVA, kW, kW-Hours, power factor, percent load, and output frequency. Pressing the “Scan” switch will activate the “Autoscan” mode where all monitored parameters are sequentially displayed automatically. Momentarily pressing the “Hold/Sequence” switch interrupts the “Autoscan” mode. Pressing the “Hold/Sequence” switch allows manual selection of the sequentially displayed parameters.

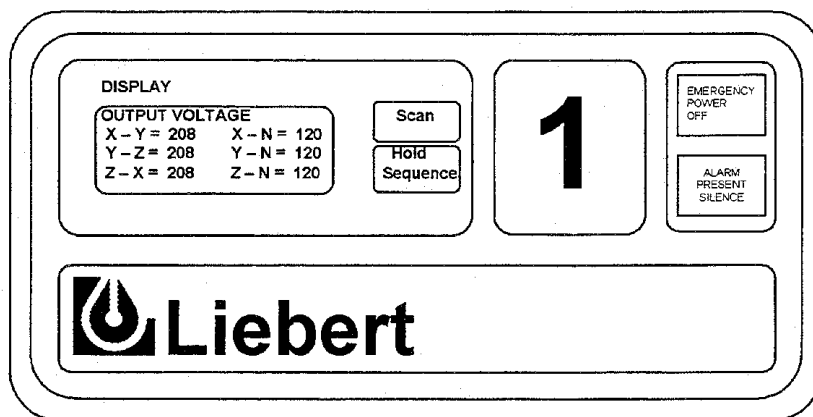

---

**Alarms** - Upon occurrence of any of the following alarms, the alarm message appears on the LCD display, the “Alarm Present/Silence” switch is illuminated, and the audible alarm is activated. Pressing the “Alarm Present/Silence” switch silences the audible alarm. After the alarm condition is corrected, the alarm can be reset by pressing the “Alarm Present/Silence” switch when prompted by the LCD display or by way of any Central Monitoring System.

**Output Overvoltage** - Indicates one or more of the output phase voltages has exceeded the preset limit (normally +6% of nominal). The high output voltage should be verified and corrective action taken. In the absence of other procedures, a normal (orderly) system shutdown should be performed to prevent load equipment damage.

**Output Undervoltage** - Indicates one or more of the output phase voltages has exceeded the preset limit (normally -13% of nominal). The low output voltage should be verified and corrective action taken. In the absence of other procedures, a normal (orderly) system shutdown should be performed to prevent load equipment damage.

**Output Voltage THD** - Indicates that the voltage distortion on one or more of the output phases has exceeded the preset limit (normally 10% THD). The cause of the high output voltage distortion should be investigated and corrective action (if any) taken.

**Transformer Overtemp** - Indicates a unit transformer overtemperature condition. The cause of the overtemperature condition should be investigated and corrected. Possible causes include unit overload, excessive non-linear loading, inadequate ventilation, high or low input voltage, or monitoring malfunction. Failure to correct the overtemperature condition may result in an automatic system shutdown due to the second stage of overtemperature sensing.

**Output Overcurrent** - Indicates one or more of the output phase currents has exceeded the preset limit (normally 95% of the unit’s full load amp rating). The overcurrent condition should be verified and corrective action taken. In the absence of other procedures, some of the output loads should be turned off to reduce unit loading. If unbalanced phase currents exist, some of the loads should be shifted from the higher loaded phase(s) to the lower loaded phase(s).

**Neutral Overcurrent** - Indicates that the neutral current has exceeded the preset limit (normally 95% of the unit’s full load amp rating). The overcurrent condition should be verified and investigated to see if corrective action is required. In some cases, high neutral current indicates phase current unbalance which should be corrected. Where high neutral currents are the result of harmonic load currents, all affected components (including output wiring) should be verified to be suitable for the current.

**Frequency Deviation** - Indicates that the output frequency has exceeded preset limits (normally  $\pm 0.5$  Hz). The frequency deviation should be verified and the cause investigated and corrected.

**Phase Sequence Error** - Indicates that the output phase sequence is not A, B, C. The phase sequence should be verified and corrective action taken. 3-phase loads sensitive to phase sequence should not be operated without proper phase sequence.

**Phase Loss** - Indicates that one or more of the phase voltages is low or missing. The low voltage condition should be verified and corrective action taken. In the absence of other procedures, a normal (orderly) shutdown should be performed to prevent equipment damage.

**Ground Overcurrent** - Indicates the system ground current has exceeded the preset limit (normally 5 amps). The overcurrent condition should be verified and corrective action taken. Possible causes are wiring errors, ground faults, or excessive leakage current.

**Customer Alarms (5)** - Indicates customer-designated alarms. The cause and corrective action depend on the nature of the alarm. See **1.2.6 - Control Wiring Connections** for contact closure connection information.

**To Set Unit Clock** - To set the clock from the unit front panel, simultaneously press the Scan and Hold membrane switches while the time and date screen is displayed on the LCD. A cursor should appear on the selected time and date field. Use the Scan switch to increment the highlighted field and the Hold switch to decrement the highlighted field. Use the Silence push button to select the next time and date field. The time can be displayed in AM/PM or 24 hour format. Simultaneously press the Scan and Hold switches to exit the clock set screen.

**RS-232 ASCII Communications Port** - Units with power monitoring are equipped with an isolated RS-232 ASCII Communications Port, which allows access to unit monitored parameters and alarm information. The RS-232 port connections are located on the low voltage control terminal strip inside the unit. See typical control wiring **Figure 13**.

The ASCII interface default parameters are as follows:

**Interface:** RS-232 Using EIA Voltage Levels  
**Baud Rate:** 9600  
**Parity:** None  
**Data Bits:** 8  
**Stop Bits:** 1  
**Terminator:** <CR>  
**Hand Shaking:** Not Supported  
**Structure:** Half-Duplex  
**Echo:** OFF  
**Change to Receive After Transmit:** 1.28 msec  
**Min. Delay to Transmit After Receive:** 120 µsec  
**Max. Response time Turn Around:** 300 msec  
**Max. Response Completion Time:** 500 msec  
**Min. Delay Between Commands:** 500 msec  
**Max. Intercharacter Delay:** 12.5 msec

The ASCII port uses a Query-Response Format.

The list of available customer commands are shown in **Table 6**. Only one command is serviced at a time. Valid commands are terminated with a carriage return [0Dh]. Commands are accepted in upper or lower case. Responses are in upper case, terminated with a line feed [0Ah] and carriage return [0Dh].

**Table 6 RS-232 ASCII Port Customer Commands**

Command	Description	Typical Response
Time?<CR> Date?<CR>	Unit Time Unit Date	03:40:37A <LF><CR> 05-15-97 <LF> <CR>
UID?<CR> KVA?<CR> V?<CR>	Unit ID Nominal kVA Nominal L-L Voltage	Unit_No_PDU_21B____<LF><CR> 0150<LF><CR> 0208<LF><CR>
SS1?<CR>	System Information (20 character fields with comma separators)	UNIT_MODEL_NUMBER____,SERIAL_NUMBER_____, SITE_ID_NUMBER_____,TAG_NUMBER_____ <LF><CR>
SA?<CR>	Number of Active Alarms, 20 character alarms with time stamp.	02,OUTPUT_OVERVOLTAGE__,05-15-97,01:25:30A, OUTPUT_OVERCURRENT__,05-15-97,01:27:46A<LF><CR>
UPMD?<CR>	Monitored Parameters, 32 Comma Separated Data Fields. See <b>Table 7</b> For Descriptions of Field Positions	0484,0485,0483,0210,0212,0211,0121,0122,0121,0068, 0085,0120,0131,0018,0030,0092,0033,0600,0038,0041, 0043,0549,0632,0599,00001528,0018,0019,0020,0045, 0047,0049,0044<LF><CR>

**Table 7 Monitored Parameters Data Definitions**

<b>Field Number</b>	<b>Data Item</b>	<b>Units</b>
1	Input Voltage A-B	Volts
2	Input Voltage B-C	Volts
3	Input Voltage C-A	Volts
4	Output Voltage X-Y	Volts
5	Output Voltage Y-Z	Volts
6	Output Voltage Z-A	Volts
7	Output Voltage X-N	Volts
8	Output Voltage Y-N	Volts
9	Output Voltage Z-N	Volts
10	Output Current X	Amps
11	Output Current Y	Amps
12	Output Current Z	Amps
13	Neutral Current	Amps
14	Ground Current	0.1 Amps
15	Output Power	kW
16	Power Factor	0.01 Power Factor
17	Output Power	kVA
18	Output Frequency	0.1 Hz
19	Output Vx THD	0.1%
20	Output Vy THD	0.1%
21	Output Vz THD	0.1%
22	Output Ix THD	0.1%
23	Output Iy THD	0.1%
24	Output Iz THD	0.1%
25	Output kW-Hrs	kW-Hrs
26	Output Ix Crest Factor	0.1
27	Output Iy Crest Factor	0.1
28	Output Iz Crest Factor	0.1
29	Output Ix K-Factor	0.1
30	Output Iy K-Factor	0.1
31	Output Iz K-Factor	0.1
32	Output Loading	% of Full Load

---

## 5.0 MAINTENANCE

---

### 5.1 Corrective Maintenance (Repair)

Even the most reliable equipment may fail. Liebert Global Services (LGS) is at your service to assure fast repair and minimize downtime of your installation.



#### WARNING

**ONLY QUALIFIED SERVICE PERSONNEL SHOULD PERFORM MAINTENANCE ON THE DATAWAVE SYSTEM**

**Standard electrical troubleshooting procedures** should be used to isolate problems in the Datawave power conditioner. *If there are questions, don't hesitate to contact Liebert Global Services.*

**Repair or replacement of standard items**, such as circuit breakers and indicator lights can be either handled by qualified electricians or referred to Liebert Global Services.

**Repairs related to the Datawave Monitoring System or power conditioning elements** should be referred to authorized qualified service personnel with training on the servicing of the unit. For assistance contact Liebert Global Services.

To contact Liebert Global Services for information or repair service in the USA, call 1-800-543-2378.

### 5.2 Preventive Maintenance (Inspection & Cleaning)

Air circulation through the Datawave cabinet may cause dust to accumulate on internal components. Cleaning should be done as necessary during electrical inspections.

Annual general system inspections, cleaning, and operation checks are recommended to ensure system performance and long service life.



#### WARNING

**ONLY QUALIFIED SERVICE PERSONNEL SHOULD PERFORM MAINTENANCE ON THE DATAWAVE SYSTEM. ALL VOLTAGE SOURCES TO THE DATAWAVE SYSTEM MUST BE DISCONNECTED BEFORE INSPECTING OR CLEANING WITHIN THE CABINET.**

#### Inspection Schedule

- It is difficult to establish a schedule for periodic cleanings since conditions vary from site to site. Inspections after the first 24 hours, 30 days, and 6 months of operation should help determine a pattern for the inspection schedule.
- Ventilation openings and grilles should be inspected and cleaned as required, every six months to a year.
- Electrical connections and component mountings should be inspected after the first 24 hours, 30 days, and 6 months of operation. Inspections should be conducted annually thereafter. Electrical connections using Belleville washers and locknuts do not require retorquing after initial system start-up. Tightness of all other electrical connections should be checked during annual electrical inspections.
- A complete inspection and operational checkout should be performed annually. This is best done by performing the inspection and start-up procedure as detailed in **3.0 - Inspection and Start-Up Checklist** and **5.3 - Datawave Magnetic Synthesizer Check**.
- Liebert Global Services offers a complete range of preventive maintenance services. These include thorough equipment performance checks and calibration of electronics. Contact Liebert Global Services. In the USA call 1-800-543-2378.



#### NOTE

*Extended product warranties are dependent on proper, regular, preventive maintenance. Contact Liebert Global Services for details.*

---

### 5.3 Datawave Magnetic Synthesizer Check



#### WARNING

**ONLY AUTHORIZED QUALIFIED SERVICE PERSONNEL TRAINED ON THE OPERATION OF THE DATAWAVE SYSTEM SHOULD PERFORM MAINTENANCE TO THE DATAWAVE POWER CONDITIONING ELEMENTS.**

The following is a brief procedure to determine if the Datawave Magnetic Synthesizer Power Conditioning elements are operating properly. This procedure does not supersede the requirements for a thorough visual and physical inspection to determine hot components, loose connections, etc. Recommended practice is to record the measure voltage and currents at start-up and at each preventive maintenance visit for comparison purpose and trend analysis.

- When the Datawave is operating properly, the output voltages (line-to-line and line-to-neutral) and the internal capacitor currents should be balanced. The capacitors are divided into four (4) three-phase capacitor banks, C1 through C4. C1 (secondary winding) and C4 (primary winding) are the main ferroresonant capacitor banks whose currents oscillate in conjunction with the six saturating pulse transformers. C2 and C3 are capacitors associated with the second and third harmonic traps. Under normal operation, the output pulses of the six saturating transformers are combined to form a step-wave approximation of sine wave. The second and third harmonic traps are used for dynamic conditions (such as start-up) to ensure proper transformer saturation sequence for a sine wave output.
- In order to properly test the operation of the synthesizer, ensure that the input voltage to the unit is near nominal (within 5%) and relatively balanced (within 3% of the average). To avoid any possible effects of unbalanced loading or harmonic load currents, the unit should be tested at no load. Also, the unit should be tested at normal operating temperatures.
- With a true RMS voltmeter, measure the output voltages line-to-line and line-to-neutral. The output voltage should be balanced within 1% of the average. The average should be within 3% of the nameplate output voltage.
- With a true RMS clamp-on current meter, measure the current of each phase of each capacitor bank.
- C2 currents can be measured on wires W141, W142, and W143 at the harmonic traps TX11, TX12, and TX13.
- C3 currents can be measured on wires W150, W151, and W152 at the harmonic traps TX14, TX15, and TX16.
- C4 can be measured by clamping on all capacitor wires connected to terminal 1 of transformer TX4 (W160, 164), TX5 (W161, 162), and TX6 (W163, 165). On 50 to 75kVA units, C4 can be measured at the capacitor tray connectors.



#### NOTE

*If parallel wires are used, measure the current in all parallel wires simultaneously to avoid summing errors.*

- The C1 capacitor current is sometimes difficult to measure directly due to wire routing. For ease of measurement, the C1 plus the C2 and C3 currents can be measured. Measure the C1+C2+C3 currents by clamping on all capacitor wires connected to terminal 3 of transformers TX4, TX5, and TX6. On 50 to 75 kVA units, measure the C1 currents on wires W166 & 170, W167 & 168, and W169 & 171 at the capacitor tray connectors.
- The measured capacitor currents should be balanced within 1.5% or 1 amp (whichever is greater). The percent unbalance equals the highest phase minus the lowest phase divided by the average of the 3-phases times 100%. The average of the measured currents should be within 5% or 1 amp (whichever is greater) of the nominal value measured at start-up. If output voltage or capacitor currents are out of tolerance, check for failed capacitors, faulty wiring, or other failed components.







## **Datawave<sup>®</sup> Magnetic Synthesizer**

**15 kVA to 75 kVA; 50 and 60 Hz**

### **Technical Support**

U.S.A.	1-800-222-5877
Outside the U.S.A.	614-841-6755
U.K.	+44 (0) 1793 553355
France	+33 1 4 87 51 52
Germany	+49 89 99 19 220
Italy	+39 2 98250 1
Netherlands	+00 31 475 503333
E-mail	upstech@liebert.com
Web site	<a href="http://www.liebert.com">http://www.liebert.com</a>
Worldwide FAX tech support	614-841-5471

### **The Company Behind The Products**

With more than 500,000 installations around the globe, Liebert is the world leader in computer protection systems. Since its founding in 1965, Liebert has developed a complete range of support and protection systems for sensitive electronics:

- Environmental systems: close-control air conditioning from 1.5 to 60 tons.
- Power conditioning and UPS with power ranges from 250 VA to more than 1000 kVA.
- Integrated systems that provide both environmental and power protection in a single, flexible package.
- Monitoring and control — on-site or remote — from systems of any size or location

Service and support, through more than 100 service centers around the world, and a 24-hour Customer Response Center.

While every precaution has been taken to ensure accuracy and completeness of this literature, Liebert Corporation assumes no responsibility, and disclaims all liability for damages resulting from use of this information or for any errors or omissions.

© 1998 Liebert Corporation. All rights reserved throughout the world. Specifications subject to change without notice.

® Liebert and the Liebert logo are registered trademarks of Liebert Corporation. All names referred to are trademarks or registered trademarks of their respective owners.

Printed in U.S.A.

SL-20141