



POWER PROTECTION

**Interceptor II, SAD Hybrid Advantage, Type SS, LM,  
AccuVar, PowerSure LPM/LPL Series, ATF Series,  
PanelGuard Extension, AccuGuide Products**

**INSTALLATION, OPERATION AND  
MAINTENANCE MANUAL**



# LIEBERT SURGE PROTECTIVE DEVICE INSTALLATION, OPERATION AND MAINTENANCE MANUAL

## TABLE OF CONTENTS

UNPACKING AND INSTALLATION .....	2
Unpacking and Preliminary Inspection.....	2
Handling Considerations.....	2
Storage .....	2
Location Considerations .....	2
Door Closing Adjustments .....	2
Warnings Defined .....	2
ELECTRICAL CONNECTIONS .....	3
Voltage Ratings and Power Source Configurations.....	3
Parallel Connection.....	3
Voltage Ratings and Power Source Configurations (Chart).....	4
Typical Parallel Connections .....	5
System Grounding and Bonding.....	6
SPD Monitoring.....	6
TROUBLESHOOTING / SERVICING / MAINTENANCE.....	7
Troubleshooting .....	7
Servicing .....	7
Corrective Maintenance.....	7
Preventative Maintenance (Inspection and Cleaning) .....	7
PRODUCT INSTALLATIONS .....	8
Typical Parallel Installation – Type SI, HA, SS, LM, ACV, LPM, & LPL.....	8
Active Tracking Filter – Type ATF Series .....	10
Type LPGE Series .....	12
AccuGuide Series .....	13
DIMENSIONAL INFORMATION.....	15
Interceptor II – Type SI Series .....	15
Hybrid Advantage – Type HA Series .....	16
AccuVar Series .....	16
Active Tracking Filter – Type ATF Series .....	17
Type SS Series.....	18
Type LM Series.....	18
PowerSure Medium Exposure – Type LPM Series.....	19
PowerSure Low Exposure – Type LPL Series.....	20
Type LPGE Series .....	21
EXAMPLE INSTALLATIONS.....	22
WARRANTY INFORMATION.....	23
10 Year Warranty.....	23
5 Year Warranty.....	25

## INSTALLATION INSTRUCTIONS

The Liebert Surge Protective Devices (SPDs) are high quality, high energy surge current diversion systems designed to protect sensitive equipment from damaging transient voltage surges. Proper installation is required for maximum system performance.

The installer should perform the following steps to assure a

quality installation. The entire installation manual should be read before starting installation. These instructions do not replace national or local electrical codes. Check applicable electrical codes to ensure compliance. Installation of the Liebert SPD system should only be performed by qualified personnel.

## UNPACKING AND INSTALLATION

### Unpacking and Preliminary Inspection

1. Inspect the shipping crate(s) for damage or signs of mishandling before unpacking the unit.
2. Remove any securing bands and cardboard packing and inspect the unit for any obvious shipping damages.
3. If any damage as a result of shipping is observed, immediately file a claim with the shipping agency and forward a copy to your local Liebert Sales Representative.

### Handling Considerations

Larger units are bolted to a shipping pallet to facilitate handling by forklift or pallet jack. Check the size and weight. Refer to the cabinet data furnished with the unit.

### Storage

The unit should be stored in a clean, dry environment. Storage temperature range is -55°C (-67°F) to +85°C (+185°F). Care should be taken to avoid condensation. All packing and shipping materials should be left intact until the unit is ready for final installation. If the unit has been stored for an extended period of time, the unit should be cleaned and carefully inspected before placing into service.

### Location Considerations

**Environment** – The unit is designed for operation indoors in ambient temperatures of -40°C (-40°F) to +60°C (+140°F) with a relative humidity of 0% to 95% (non-condensing).

The unit is provided in an industrial use enclosure, which is dust-tight and drip-tight and should not be installed in areas with excessive dust, corrosive vapors, flammable materials or explosive atmospheres.

**Audible Noise** – The audible noise of the unit is less than 40 dB at 5 feet, which allows its placement within almost any room if desired.

**Service Clearances** – Service clearance is needed for units with hinged doors on the front that are capable of being opened. Thirty-six inches (36 in / 914 mm) minimum is recommended.



### **EQUIPMENT PERFORMANCE!!**

**For maximum system performance, the unit must be located as close to the protected circuit as practical to minimize interconnecting wiring length.**

For optimum transient surge protection, coordinated surge suppression should be applied at the service entrance and all other electrical connections to the building (telephone, CATV, etc.), at known surge generating loads within the building (large motors, arc welders, switched capacitors, etc.), as well as at sensitive electronic loads (such as computers, electronic appliances, solid state motor drives, etc.). For interconnected electronic loads (such as by way of data cabling), transient surge suppression should also be applied to the interconnecting wiring (data cables).

**Mounting** – Unit is intended to be wall mounted. Refer to individual instruction sheet or unit submittal drawings for typical mounting dimensions and weight.

### Warnings Defined

	<p><b>Danger:</b> Indicates an imminently hazardous situation that, if not avoided, will result in death or serious injury. This signal word is to be limited to the most extreme situations.</p>
	<p><b>Warning:</b> Indicates a potentially hazardous situation that, if not avoided, could result in death or serious injury.</p>
	<p><b>Caution:</b> Indicates a potentially hazardous situation that, if not avoided, may result in minor or moderate injury. It may also be used to alert against unsafe practices.</p>

---

## ELECTRICAL CONNECTIONS

---

All electrical connections should be installed by a qualified (licensed) electrician only. All wiring must comply with the National Electrical Code (NEC) and applicable local codes.

### **DANGER**

**VERIFY THAT ALL POWER CIRCUITS ARE DE-ENERGIZED AND LOCKED OUT BEFORE MAKING ELECTRICAL CONNECTIONS.**

---

### **Voltage Ratings and Power Source Configurations**

---

### **CAUTION**

Before making connections to the unit, verify that the unit model number and nameplate voltage rating are appropriate for connection to the intended power source. See the chart on page 4 for voltage rating applications with typical power source configurations.

---

### **Parallel Connection (see Figures on page 5)**

---

**With parallel connection, the length of the wiring to the surge protective device (SPD) unit must be minimized for best performance. Wires should be as short and straight as possible.**

To reduce the wiring impedance to surge currents, it is recommended that the phase, neutral (if required), and ground conductors are twisted together and routed in the same raceway (conduit). Avoid any sharp bends in the conductors.

**Wire Sizing** – With parallel connection, the size of the wiring to the SPD unit is independent of the protected circuit's ampacity. For suggested wire size refer to individual product sheet.

NEC Article 285-21(B) requires surge suppressor connecting conductors to be at least #14 copper or #12 aluminum.

**Overcurrent Protection** – The SPD unit conducts practically no current under normal operation and only conducts very short duration transient surge currents.

The following is from the National Electric Code 2002 Edition.

**285.21 Connection.** Where a TVSS is installed, it shall be connected as follows:

**(A) Location.**

- (1) **Service Supplied Building or Structure.** The transient voltage surge suppressor shall be connected on the load side of a service disconnect overcurrent device required in 230.91.
- (2) **Feeder Supplied Building or Structure.** The transient voltage surge suppressor shall be connected on the load side of the first overcurrent device at the building or structure.

*Exception to (1) and (2): Where the TVSS is also listed as a surge arrester, the connection shall be as permitted by Article 280.*

- (3) **Separately Derived System.** The TVSS shall be connected on the load side of the first overcurrent device in a separately derived system.

**Disconnect Switch (If Provided)** – All SPD units must still be connected to the load side of the main service disconnect, or load side of a protected circuit's disconnecting means.

**Surge Voltage Ratings** – To obtain the suppression voltage ratings (SVRs), as obtained by Underwriters Laboratory, Incorporated, in accordance with the *Standard for Safety, Transient Voltage Surge Suppressors (TVSS), Standard 1449, Second Edition, dated August 15, 1996*, marked on this product, The wire size listed for each product must be utilized to connect the unit to your facilities' power grid. Connections made with conductors other than the wire size listed may result in different SVRs.

**Circuit Ampacity Limitations** – Representative samples of these products have been investigated by Underwriters Laboratories, Incorporated to withstand, without exposing live circuits or components at system voltages and fault currents ranging from 14,000 AIC up to 200,000 AIC, as described in the *Standard for Safety, Transient Voltage Surge Suppressor (TVSS), Standard 1449, Second Edition, dated August 15, 1996*. Verify each product's fault current rating on the individual installation pages that follow.

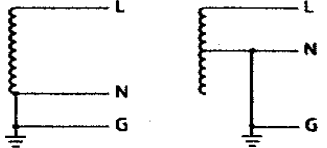
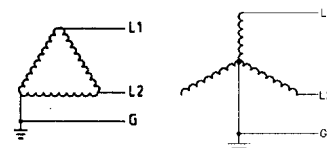
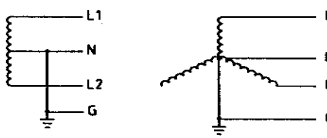
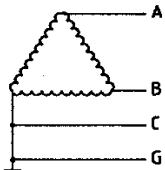
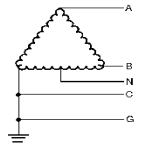
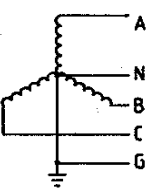
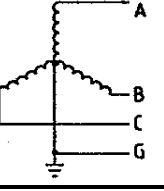
<b>VOLTAGE RATINGS &amp; POWER SOURCE CONFIGURATIONS</b>					
Source Configurations	Nominal Operating Voltage			Maximum Continuous Operating Voltage	Model Voltage Code (Found in part number)
	L-N	L-G	L-L		
<b>Single Phase L-N, 2 W + G</b>					
	120	120	N/A	150 L-N	<b>120N or 120-</b>
	230	230	N/A	275 L-N	<b>230N or 230-</b>
	277	277	N/A	320 L-N	<b>277N or 277-</b>
	346	346	N/A	420 L-N	<b>346N or 346-</b>
<b>Single Phase L-L, 2 W + G</b>					
	N/A	208	208	300 L-L	<b>208L or 208-</b>
	N/A	240	240	300 L-L	<b>240L or 240-</b>
	N/A	400	400	580 L-L	<b>400L or 400-</b>
	N/A	480	480	580 L-L	<b>480L or 480-</b>
	N/A	600	600	680 L-L	<b>600L or 600-</b>
<b>Split Single Phase 3 W + G</b>					
	120	120	208, 240	150 L-N	<b>120S</b>
	240, 277	240, 277	480	320 L-N	<b>240S</b>
	346	346	600	420 L-N	<b>346S</b>
<b>Three Phase Delta, 3 W + G</b>					
	N/A	208	208	300 L-L	<b>208D</b>
	N/A	240	240	300 L-L	<b>240D</b>
	N/A	400	400	580 L-L	<b>400D</b>
	N/A	480	480	580 L-L	<b>480D</b>
	N/A	600	600	680 L-L	<b>600D</b>
<b>Three Phase Delta Hi Leg, 4 W + G</b>					
	A / B / C	A / B / C		A & C / B	
	120/240/120	120/240/120	240	150/320 L-N	<b>240H</b>
	240/480/240	240/480/240	480	320/580 L-N	<b>480H</b>
<b>Three Phase Wye, 4 W + G</b>					
	120	120	208	150 L-N	<b>120Y</b>
	127	127	220	150 L-N	<b>127Y</b>
	220	220	380	320 L-N	<b>220Y</b>
	230	230	400	320 L-N	<b>230Y</b>
	254	254	440	320 L-N	<b>254Y</b>
	277	277	480	320 L-N	<b>277Y</b>
	346	346	600	420 L-N	<b>346Y</b>
<b>Three Phase Wye, 3 W + G No Neutral</b>					
	N/A	120	208	150 L-G	<b>120X or 120Y110</b>
	N/A	127	220	150 L-G	<b>127X or 127Y110</b>
	N/A	220	380	320 L-G	<b>220X or 220Y110</b>
	N/A	230	400	320 L-G	<b>230X or 230Y110</b>
	N/A	254	440	320 L-G	<b>254X or 254Y110</b>
	N/A	277	480	320 L-G	<b>277X or 277Y110</b>
	N/A	346	600	420 L-G	<b>346X or 346Y110</b>

Note 1: For other voltages or source configurations, consult factory.

### Voltage Ratings and Power Source Configurations

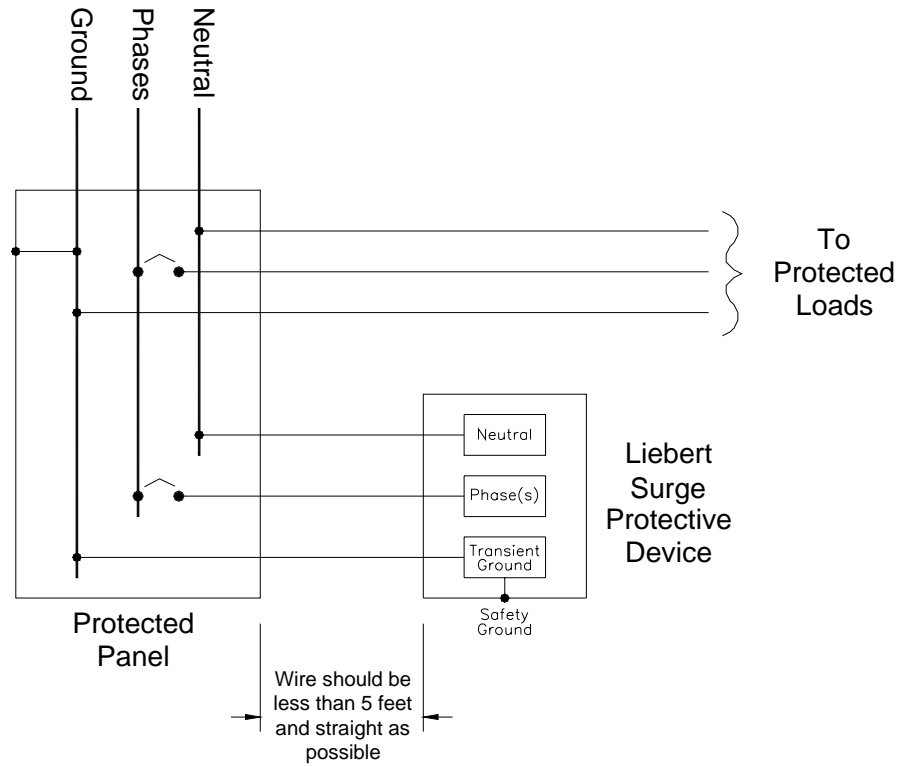

**Typical Parallel Connections (without Internal Rotary Disconnect)**

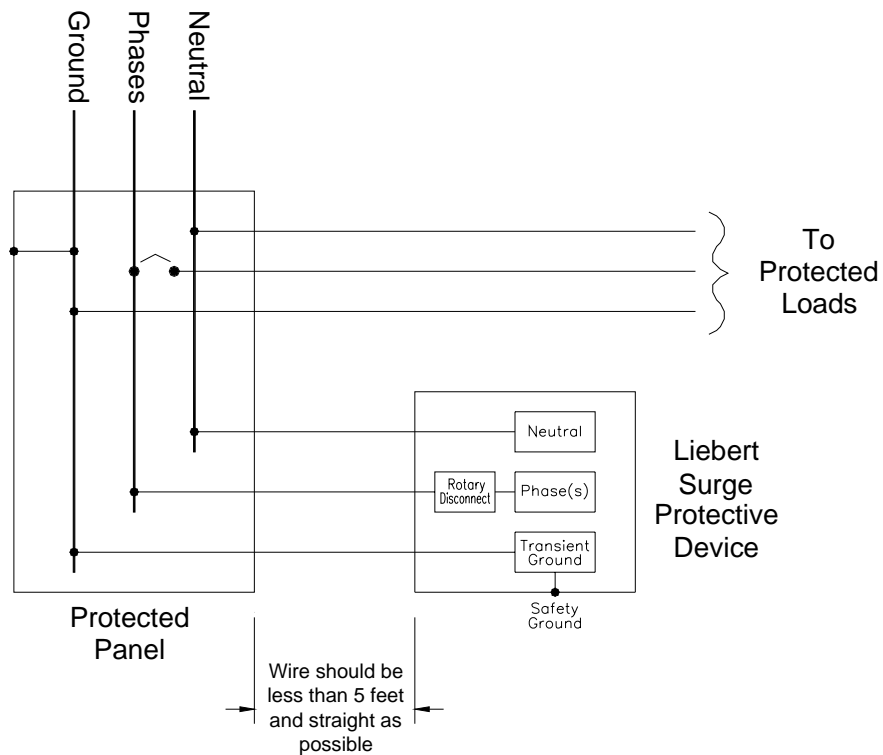

**Typical Parallel Connections (with Internal Rotary Disconnect)**

---

## System Grounding and Bonding

---

The performance and safety of any SPD system is dependent on proper grounding and bonding. Grounding is required for safety. Correct implementation also enhances equipment performance. Incorrect grounding can reduce or impede the SPD's operation.

All electrical circuits to the SPD must include an equipment-grounding conductor as required by the NEC and local codes.

An insulated grounding conductor is required in addition to any metallic raceway, which may be used as a grounding conductor. For parallel-connected SPDs, the grounding conductor should be the same wire size as the associated power conductors. Grounding conductors must be routed with the associated power conductors in the same raceway (conduit).

When metallic raceways are used, adequate electrical continuity must be maintained at all raceway connections, particularly raceway terminations to the electrical enclosures.

**The use of isolating bushings or other means to interrupt a metallic conduit run is a potential safety hazard and is not recommended.**

**Grounding Electrode** – Surge protective devices do not discharge all surges to ground (earth). Surge protective devices divert the surge current back to its source to complete the electrical circuit.

In the case of lightning whose potential is developed with respect to the earth, the SPD diverts the surge current to the grounding electrode (earth connection). However, for most transient surges that are developed by switching loads, the SPD diverts the surge current back to its source without involving the grounding electrode.

For proper SPD performance, the service entrance grounding electrode system must comply with the NEC by having all available electrodes (building steel, metal water pipe, driven rods, concrete encased electrodes, etc.) properly bonded together and connected to the power system grounding.

The use of a separate grounding electrode to ground the SPD defeats the effectiveness of the SPD, is a potential safety hazard, may cause equipment damage, is a NEC violation (reference NEC 250-51 and 250-54), and is not recommended.

## **▲ CAUTION**

**FOR PROPER AND SAFE OPERATION, THE NEUTRAL, (IF PROVIDED), MUST BE RELIABLY CONNECTED TO THE NEUTRAL OF THE SOURCE. FAILURE TO PROVIDE A RELIABLE NEUTRAL CONNECTION MAY RESULT IN MODULE FAILURE!**

---

## SPD Monitoring

---

**External Status Indicators** – These indicators provide a summary of the status of the surge SPD module. For normal conditions, the green “OK” LED is illuminated and the red “Service” LED is extinguished. If the surge SPD module requires replacement, the green “OK” LED is turned off and the red “Service” LED illuminated.

**Summary Alarm Contact (if applicable)** – Summary alarm Form C (1 N.O. and 1 N.C.) relay contacts may be provided for remote indication of the failed surge SPD module.

Contacts are rated 5 amps at 250 VAC maximum with a power factor of 1.0. For units with Summary Alarm Contacts, access to the contacts are typically provided via contact terminals located on the printed circuit board mounted on the inside of the unit's cover.

**Transient Counter (if applicable)** – Transient counters are provided for transient voltage surge monitoring. The counter totalizes surges monitored since the last counter reset.

The transient counter monitors line transient voltages. The circuit totalizes all surges that deviate from the line sine wave envelope by more than a selected percentage. The factory setting is 30% over nominal line voltage. Other settings include 50%, 70%, and 100%.

**Swell Counter (if applicable)** – Swell counters are provided for line voltages that rise 30% above the nominal line voltage for more than 50msec. The counter totalizes swells monitored since the last counter reset.

**Audible Alarm (if applicable)** – If the surge SPD module requires replacement, an audible alarm is activated to draw attention to the fact that repair service is required to restore the system to normal operation. An audible alarm disable is provided to silence the alarm. The system will automatically reset itself after repair. The audible alarm switch and “Service” LED can be tested by depressing the “Test” switch on the system monitor panel.

---

## TROUBLESHOOTING / SERVICING / MAINTENANCE

---

---

### Troubleshooting

---

If status failure indication occurs or Form C relay has changed states, a qualified electrician shall first determine if the systems voltage and proper phasing exists.

If the SPD remains in an alarm condition once the electrician is satisfied that the electrical system and its connections are normal, the unit should be repaired. At this point consult the factory, having available the following information:

- Unit identification number – (*refers to the model and serial numbers detailed on the data label and is located on the front or upper left [hinge] side of the enclosure.*)
- Nature of problem – (*including status of all status indicators and alarms*).

---

### Servicing

---



**ONLY QUALIFIED PERSONNEL SHOULD PERFORM MAINTENANCE ON THE SYSTEM.**

**HAZARDOUS VOLTAGES ARE PRESENT INSIDE THE UNIT DURING NORMAL OPERATIONS.**

**ELECTRICAL SAFETY PRE-CAUTIONS MUST BE FOLLOWED WHEN SERVICING THIS UNIT.**

**TO PREVENT RISK OF ELECTRICAL SHOCK, TURN OFF AND LOCK OUT ALL POWER SOURCES TO THE UNIT BEFORE SERVICING UNIT.**

**(For servicing assistance, contact your local Liebert Sales Representative or Liebert at 800-288-6169 or 607-724-2484.)**

---

### Corrective Maintenance

---

The Liebert SPD is designed for years of trouble-free operation. However, even the most reliable equipment may fail under abnormal conditions.

Diagnostic indicators are provided to indicate when the unit needs replacement (see individual SPD operation of this manual for details). To ensure continuity of surge protection, failed units should be replaced at the earliest convenient service opportunity.

When replacing surge modules, other components should be inspected for damage and replaced if necessary. Standard electrical troubleshooting procedures should be used to isolate problems other than failed surge current diverter modules.

When replacing components, for continued proper operation and safety, replace only with identically rated components. Please contact factory for information on replacement parts.

---

### Preventative Maintenance (Inspection and Cleaning)

---

Periodic system inspections, cleaning, and connection checks are recommended to ensure reliable system performance and continued surge transient protection.

It is difficult to establish a schedule for preventative maintenance since conditions vary from site to site. Inspections for failed surge modules using available diagnostics should be done routinely (weekly or monthly).

## Typical Parallel Installations

### Surge Protective Devices (SPD)



**PowerSure Medium Exposure  
Type LPM Series**



**AccuVar Series**



**PowerSure Low Exposure  
Type LPL Series**



### INSTALLATION INSTRUCTIONS

1. Insure that all power is removed before beginning installation. A qualified licensed electrician shall install all electrical connections.
2. The SPD is provided in the enclosure type listed below. NEMA 12 enclosures are suitable for use in indoor installations. NEMA 3R, NEMA 4 or NEMA 4X enclosures are suitable for use in indoor or outdoor installations.

SPD	Standard Enclosure	Optional Enclosures	SPD	Standard Enclosure	Optional Enclosures
Type SI	NEMA 4	NEMA 4X	Type ACV	NEMA 4X	N/A
Type HA	NEMA 12	NEMA 3R, 4, 4X	Type LPM	NEMA 12	NEMA 3R, 4, 4X
Type SS	NEMA 4X	N/A	Type LPL	ABS Plastic 94V-0	NEMA 1
Type LM	NEMA 12	NEMA 3R, 4, 4X			

3. Determine where the SPD is to be mounted, allowing for minimum length of wire between itself and the input power terminals of the service panel. Punch or cut proper hole size in the side of the SPD closest to the knockout to be utilized in the service panel. Drill mounting holes in wall at location picked for SPD next to service panel using mounting dimensions shown in the tables on the "Dimensional Information" pages in this manual. Mount surge suppressor using the hardware listed.

SPD	Mounting Hardware	SPD	Mounting Hardware
Type SI (Page 15)	3/8-16	Type ACV (Page 16)	#10
Type HA (Page 16)	3/8-16	Type LPM (Page 19)	10-32
Type SS (Page 18)	1/4-20	Type LPL (Page 20)	6-32
Type LM (Page 18)	1/4-20		

4. The SPD has obtained the short circuit current rating shown below.

SPD	Short Circuit Current Rating	SPD	Short Circuit Current Rating
Type SI	200,000 Symmetrical Amperes	Type ACV	200,000 Symmetrical Amperes
Type HA	200,000 Symmetrical Amperes	Type LPM	65,000 Symmetrical Amperes
Type SS	65,000 Symmetrical Amperes	Type LPL	14,000 Symmetrical Amperes
Type LM	200,000 Symmetrical Amperes		

**Circuit Ampacity Limitations.** Representative samples of these products have been investigated by Underwriters Laboratories, Incorporated to withstand, without exposing live circuits or components at system voltages and fault currents of up to the rating shown above, as described in the *Standard for Safety, Transient Voltage Surge Suppressor (TVSS), Standard 1449, Second Edition*, dated August 15, 1996.

An external circuit breaker is not necessary for over-current protection for most units (LPL Units require a 30A circuit breaker). However, it is recommended that the SPD be connected in series with a circuit breaker denoted in the tables below (also indicated on the “Dimensional Information” pages in this manual). The SPD shall be connected in accordance with all national and local electrical codes.

- Connect black wires (line or phase) marked L1/A, L2/B or L3/C, the white wire (neutral) marked N, and the green wire (ground) marked G, of the SPD using the wire range listed below. To yield the best performance of the SPD within the electrical distribution system, keep all conductors as short as possible and avoid sharp bends.

**If the SPD model is a Wye configured unit (4W+G), and a Neutral connection is not available, please contact factory.**

Series	Model #	Suggested Breaker Size	Wire Range
Interceptor II	SI016 - SI025	60 Amp	#6 - #4
	SI032 - SI050	80 Amp	#4 - #2
	SI060 - SI075	80 Amp	#4 - #2
	SI100	100 Amp	#2 - 1/O
Hybrid Advantage	Hxxxx111 (250kA)	60 Amp	#6 - #4
	Hxxxx222 (320kA)	80 Amp	#4 - #2
	Hxxxx333 (400kA)	80 Amp	#4 - #2
	Hxxxx444 (750kA)	80 Amp	#4 - #2
SS Series	All Units	60 Amp	#6 - #4
LM Series	LM060 - LM080	40 Amp	#8 - #6
	LM100 - LM125	40 Amp	#8 - #6
	LM150	80 Amp	#4 - #2
	LM200 - LM250	100 Amp	#4 - #2
AccuVar	All Units	30 Amp	#10
PowerSure LPM	All Units	30 Amp	Included with Unit
PowerSure LPL	All Units	30 Amp	Included with Unit

**Surge Voltage Ratings.** To obtain the suppression voltage ratings (SVRs), as obtained by Underwriters Laboratory, Incorporated, in accordance with the *Standard for Safety, Transient Voltage Surge Suppressors (TVSS), Standard 1449, Second Edition*, dated August 15, 1996, marked on this product, the suggested wire size must be utilized to connect the unit to your facilities power grid. Connections made with conductors other than the size provided may result in different SVRs.

- Connection to Form ‘C’ contacts shall be with #18 – 22 AWG. The ratings of the Form ‘C’ contacts are 5 amps at 250 VAC maximum with a power factor of 1.0.
- Apply power. The surge protector is fully operational when the GREEN LEDs on the modules and the front door of enclosure are illuminated. If the GREEN LEDs are extinguished or a RED LED is illuminated, check to ensure that power is applied to the SPD. If an abnormal indication is present, remove power to the SPD and contact Liebert/Control Concepts at 1-800-288-6169 or 1-607-724-2484.
- Periodically monitor the status of the LEDs. Reduced protection exists if the GREEN LEDs are extinguished or the RED LED is illuminated. Please contact Liebert/Control Concepts at 1-800-288-6169 or 1-607-724-2484.
- The protection modules in these SPDs may be replaceable, contact Liebert/Control Concepts for replacement. (Note: ACV, LPM, & LPL units do not have replaceable modules.)

# Liebert Active Tracking Filter

## Type ATF Series

### Surge Protective Device (SPD)



## INSTALLATION INSTRUCTIONS

1. Ampacity: The filter's maximum continuous current (Ampere) rating must be greater than or equal to the protected load's full load amps or overcurrent protection (Circuit Breaker) rating.
2. Insure that all power is removed before beginning installation. A qualified licensed electrician shall install all electrical connections
3. The SPD is provided in a NEMA 3R, NEMA 4, NEMA 4X or NEMA 12 enclosure. The SPD is suitable for use in indoor (NEMA 12) or outdoor (NEMA 3R, 4, 4X) installations.
4. Determine where the SPD is to be mounted. Punch or cut proper hole size in the side of the SPD closest to the knockout to be utilized in the service panel. Wall Mounted Units: Drill mounting holes in wall at location picked for SPD next to service panel using mounting dimension from the tables on page 17. Mount surge suppressor using 3/8-16 hardware or equivalent.
5. Units up to 225 amps are suitable for short circuit current ratings up to 25,000 amps. For short circuit currents up to 50,000 amps, Class RK5 fuses sized up to 125% of the filter's continuous current rating are required. Units rated at 400 to 800 amps are suitable for available symmetrical short circuit currents up to 50,000 amps. For short circuit currents up to 100,000 amps, Class L Fuses sized up to 125% of the filter's continuous current rating are required. Units 1200 amps and above are suitable for available symmetrical short circuit currents up to 200,000 amps.
6. For best performance, keep input and output wiring separated as much as practical to eliminate input-to-output coupling of noise and transients. Do not route input and output wiring in the same raceway. If practical, terminate input and output raceways (conduits) at opposite ends of the active tracking filter enclosure (input near the top and output near the bottom).
7. The Liebert Active Tracking Filter System is wired in-line (in series) with the protected load(s). See Figures on the following page.
8. Terminals are provided inside the Liebert Active Tracking Filter System for the line (phase), neutral (if used), transient ground, and equipment safety ground connections. See page 11 for terminal wire size ranges.
9. Connect black wires (line or phase) marked L1/A, L2/B or L3/C, the white wire (neutral) marked N, and the green wire (ground) marked G, of the SPD using the wire range listed in the table on page 12 in accordance with the National Electric Code (NEC) Article 285 and all local codes. To yield the best performance of the SPD within the electrical distribution system, avoid sharp bends.
10. Connection to the Form 'C' contacts shall be with #18 – 22 AWG. Contacts are rated 5 amps at 250 VAC maximum with a power factor of 1.0.
11. Apply power. The surge protector is fully operational when the GREEN LEDs on the modules and the front door of enclosure are illuminated. If the GREEN LEDs are extinguished or the RED LED is illuminated, check to ensure that power is applied to the SPD. If an abnormal indication is present, remove power to the SPD and contact Liebert/Control Concepts at 1-800-288-6169 or 1-607-724-2484.
12. Periodically monitor the status of the LEDs. Reduced protection exists if the GREEN LEDs are extinguished or the RED LED is illuminated. Please contact Liebert/Control Concepts at 1-800-288-6169 or 1-607-724-2484.
13. The protection modules in these SPDs are replaceable, contact Liebert/Control Concepts for replacement.

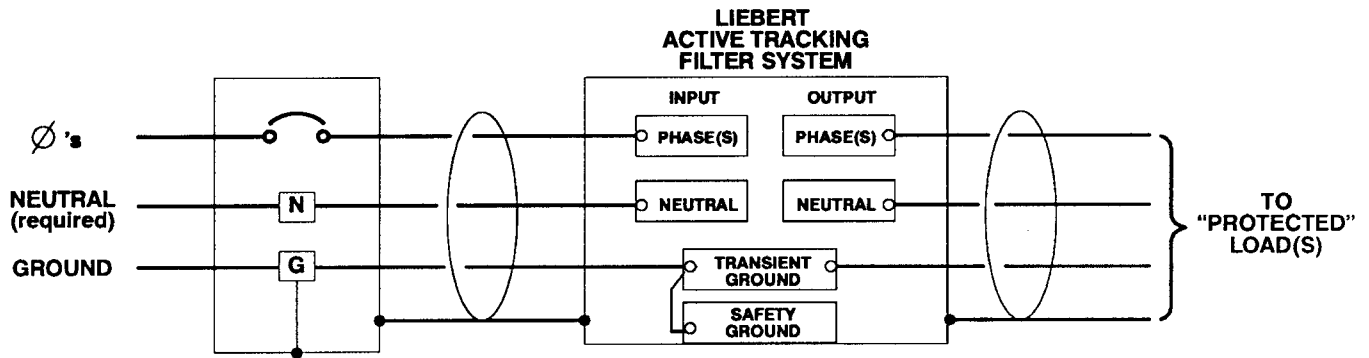

Typical Series Connections for Wye (4 Wire + Ground) or Single Phase (3 Wire + Ground) System

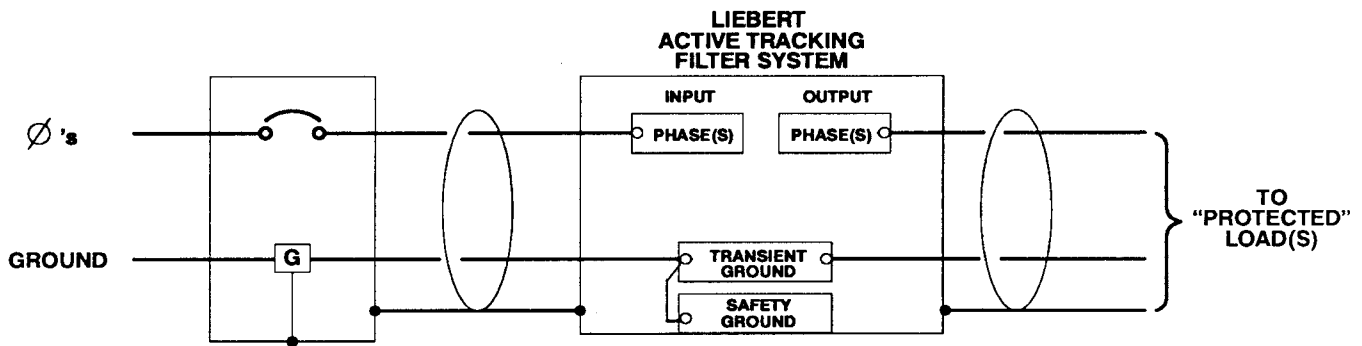

Typical Series Connections for Delta (3 Wire + Ground) System

### TERMINAL WIRE SIZE RANGE

FILTER CONTINUOUS CURRENT RATING	PHASE AND NEUTRAL TERMINALS	TRANSIENT GROUND TERMINAL	SAFETY GROUND TERMINAL
30 – 100 A	# 14 – 2/0 (1)	# 14 – 2/0 (5)	# 14 - # 4 (4)
225 A	# 6 – 250 kcmil (1)	# 14 – 2/0 (5)	# 10 – 1/0 (4)
400 A	# 6 – 250 kcmil (2)	# 6 – 250 kcmil (2)	# 6 – 250 kcmil (4)
800 A	2.75 x .50 Cu Busbar (3)	# 6 – 250 kcmil (2)	# 6 – 250 kcmil (4)
1200 A	(2x) 6.0 x .25 Cu Busbar (3)	# 6 – 250 kcmil (2)	# 6 – 250 kcmil (4)
2000 A	(3x) 6.0 x .25 Cu Busbar (3)	# 6 – 250 kcmil (2)	# 6 – 250 kcmil (2)
4000 A	(5x) 6.0 x .25 Cu Busbar (3)	# 6 – 250 kcmil (2)	# 6 – 250 kcmil (2)

**NOTES:**

1. Single lug with single connection for Input and Output.
2. Single lug with dual connection for Input and Output.
3. Units must be installed with Busbar(s) only! Wire lugs are not U.L. approved.
4. Single lug with single connection.
5. Single lug with dual connection.

# Liebert Type LPGE Series

## Surge Protective Device (SPD)



### INSTALLATION INSTRUCTIONS

1. Insure that all power is removed before beginning installation. A qualified licensed electrician shall install all electrical connections
2. The unit is provided in a NEMA 1 rated industrial-use enclosure and should be installed in areas only appropriate for NEMA 1.
3. The unit is to be wall mounted in an area where sufficient access and working space around the cabinet can be assured. (See NEC Section 110-16.) Position the SPD opposite the incoming feed to the panelboard. For example, if the panelboard is supplied through the top of its enclosure, mount the SPD at the bottom of the panelboard.
4. Knockouts for connection of the suppressor to the panelboard back box are provided on top, bottom, and sides of the unit's enclosure. The diameters of the knockouts vary to accommodate conduit / collar diameters of 1/2 in. to 1 1/4 in. The proper size busing (diameter and length) must be selected to protect the conductors as they transition from the SPD to the panelboard conductor, and to maintain the cosmetic integrity of the Liebert LPGE Series Surge Protection Device.
5. When connecting the SPD to the panelboard, it is important that the panelboards interior and the SPD are protected from any metal shavings, which may result. An inspection and cleaning of the LPGE should be performed before applying power.
6. Representative samples of this product have been investigated by Underwriters Laboratories, Incorporated to withstand, without exposing live circuits or components at system voltages and fault currents of up to 200,000 AIC, as described in the *Standard for Safety, Transient Voltage Surge Suppressor (TVSS), Standard 1449, Second Edition*, dated August 15, 1996.
7. An external circuit breaker is not necessary for over-current protection. However, it is recommended that the SPD be connected in series with a 30A circuit breaker. The SPD shall be connected in accordance with all national and local electrical codes.
8. To obtain the suppression voltage ratings (SVRs), as obtained by Underwriters Laboratory, Incorporated, in accordance with the *Standard for Safety, Transient Voltage Surge Suppressors (TVSS), Standard 1449, Second Edition*, dated August 15, 1996, marked on this product, #8 AWG wire must be utilized to connect the unit to your facilities power grid. Connections made with conductors other than #8 AWG may result in different SVRs.
9. Connect black wires (line or phase) marked L1/A, L2/B or L3/C, the white wire (neutral) marked N, and the green wire (ground) marked G, of the SPD using the wire range listed in the table below in accordance with the National Electric Code (NEC) Article 285 and all local codes. To yield the best performance of the SPD within the electrical distribution system, keep all conductors as short as possible and avoid sharp bends.
10. Connection to the Form 'C' contacts shall be with #18 – 22 AWG. Contacts are rated 5 amps at 250 VAC maximum with a power factor of 1.0.
11. Apply power. The surge protector is fully operational when the GREEN LEDs are illuminated. If the GREEN LEDs are extinguished, check to ensure that power is applied to the SPD. If an abnormal indication is present, remove power to the SPD and contact Liebert/Control Concepts at 1-800-288-6169 or 1-607-724-2484.
12. Periodically monitor the status of the LEDs. Reduced protection exists if the GREEN LEDs are extinguished. Please contact Liebert/Control Concepts at 1-800-288-6169 or 1-607-724-2484.
13. The protection modules in these SPDs are replaceable, contact Liebert/Control Concepts for replacement.

# Liebert AccuGuide Series

## SPD Interconnect Assembly



### INSTALLATION INSTRUCTIONS

All electrical connections shall be installed by a qualified (licensed) electrician. All wiring must comply with the National Electrical Code (NEC) and applicable local codes.

---

## National Electrical Code (NEC) Considerations

---

The National Electrical Code Article 240-21 details specific tap rules that should be considered before installation.

**NEC 240.21 Location in Circuit.** Overcurrent protection shall be provided in each ungrounded circuit conductor and shall be located at the point where the conductors receive their supply except as specified in 240.21(A) through (G). No conductor supplied under the provisions of 240.21(A) through (G) shall supply another conductor under those provisions, except through an overcurrent protective device meeting the requirements of 240.4.

- (A) **Branch-Circuit Conductors.** Branch-circuit tap conductors meeting the requirements specified in 210.19 shall be permitted to have overcurrent protection located as specified in that section.
- (B) **Feeder Taps.** Conductors shall be permitted to be tapped, without overcurrent protection at the tap, to a feeder as specified in 240.21(B)(1) through (5).
  - (1) **Taps Not Over 3 m (10 ft) Long.** Where the length of the tap conductors does not exceed 3 m (10 ft) and the tap conductors comply with all of the following:
    - (1) The Ampacity of the tap conductors (25 Amps in our case) is
      - a. Not less than the combined computed loads on the circuits supplied by the tap conductors, and
      - b. Not less than the rating of the device supplied by the tap conductors or not less than the rating of the overcurrent protective device at the termination of the tap conductors.
    - (2) The tap conductors do not extend beyond the switchboard, panelboard, disconnecting means, or control devices they supply.
    - (3) Except at the point of connection to the feeder, the tap conductors are enclosed in a raceway, which shall extend from the tap to the enclosure of an enclosed switchboard, panelboard, or control devices, or to the back of an open switchboard.
    - (4) For field installations where the tap conductors leave the enclosure or vault in which the tap is made, the rating of the overcurrent device on the line side of the tap conductors shall not exceed 10 times the Ampacity of the tap conductor.
  - (2) **Taps Not Over 7.5 m (25 ft) Long.** Where the length of the tap conductors does not exceed 7.5 m (25 ft) and the tap conductors comply with all of the following:
    - (1) The Ampacity of the tap conductors is not less than one-third of the rating of the overcurrent device protecting the feeder conductors (75 Amp maximum in our case).
    - (2) The tap conductors terminate in a single circuit breaker or a single set of fuses that will limit the load to the Ampacity of the tap conductors. This device shall be permitted to supply any number of additional overcurrent devices on its load side.
    - (3) The tap conductors are suitably protected from physical damage or are enclosed in a raceway.
  - (3) **Taps Supplying a Transformer...** Not Applicable
  - (4) **Taps Over 7.5 m (25 ft) Long.** Not Applicable
  - (5) **Outside Taps of Unlimited Length.** Not Applicable

Flexible liquid tight non-metallic conduit in lengths greater than six feet must be installed in accordance with NEC 351-27.

## Connection

The AccuGuide assembly is provided in standard lengths of 5, 8, 10, 12, 15, and 20 feet. Each end of the assembly will include an additional five feet of #10, 8, 6, or 4 AWG pigtails for connection to the service and to the surge protective device (SPD). Gauge of the pigtail is based on the SPD lug size. See chart below for units and acceptable wire ranges. An additional 10 gauge-grounding conductor is provided with the AccuGuide assembly for use as an equipment ground.

Interceptor II Units	Acceptable Wire Range
All Units - No Disconnect	#14 – 2/O
SI016-025 – With Disconnect	#8 – 1/O
SI032-100 – With Disconnect	#14 – 2/O
LM Units	Acceptable Wire Range
All Units - No Disconnect	#14 – #2
LM060-080 – With Disconnect	#8 – 1/O
LM100-250 – With Disconnect	#14 – 2/O

## Conduit

The AccuGuide assembly is sold without conduit. If conduit housing is required, the following conduit and fitting sizes apply:

No. of Coaxial Cables	Conduit Size (in.)
1	1/2
2	1
3	1
4	1 1/4
5	1 1/4
6	2
7	2

## EQUIPMENT PERFORMANCE

The ideal SPD installation locates the suppression as close to the protected bus as possible. This product was designed to address those instances when a close installation is not possible. However, while the voltage drop experienced with an AccuGuide assembly is significantly reduced, care should be taken to keep connection lengths to a minimum.

Each end of the AccuGuide assembly is shipped with five-foot pigtails. The length is offered as a worst-case need for the panel or switchgear end (our SPD will be much less than 5 feet). We recommend cutting the pigtail to the shortest length possible.

### CAUTION

**Caution:** Pigtails must be supported if pulling AccuGuide assembly through conduit. Grip only the blue coaxial cable body when pulling the assembly through conduit. **Do not** pull AccuGuide assembly using the pigtails or damage may occur.

## Dimensional Information

### Interceptor II - Type SI Series

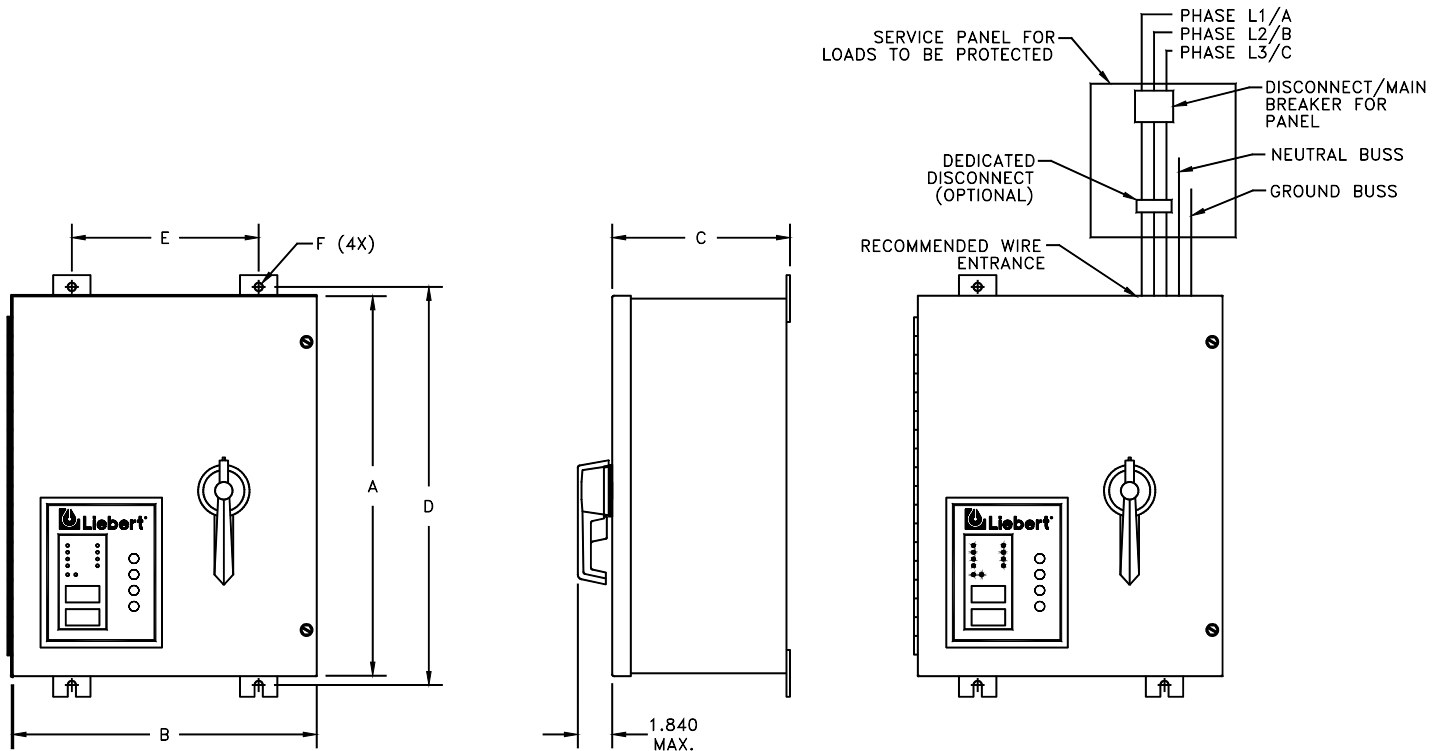

#### Interceptor II, Type SI

Surge Capacity	Suggested Breaker	Wire Range (AWG)	Dimensions (Inches)						Weight (lbs)
			A	B	C	D	E	F	
016 – 025	60 A	6 – 4	16	12	8	17.25	9.5	0.44	35
032 – 050	80 A	4 – 2	16	16	8	17.25	10.0	0.44	49
060 – 075	80 A	4 – 2	20	16	8	21.25	10.0	0.44	55
100	100 A	2 – 1/0	20	20	8	21.25	14.0	0.44	85

#### Interceptor II, Type SI w/Rotary Disconnect

Surge Capacity	Suggested Breaker	Wire Range (AWG)	Dimensions (Inches)						Weight (lbs)
			A	B	C	D	E	F	
016 – 025	60 A	6 – 4	16	16	8	17.25	10.0	0.44	45
032 – 050	80 A	4 – 2	20	16	8	21.25	10.0	0.44	58
060 – 075	80 A	4 – 2	20	20	8	21.25	14.0	0.44	85
100	100 A	2 – 1/0	20	24	8	21.25	18.0	0.44	95

## Hybrid Advantage - Type HA Series

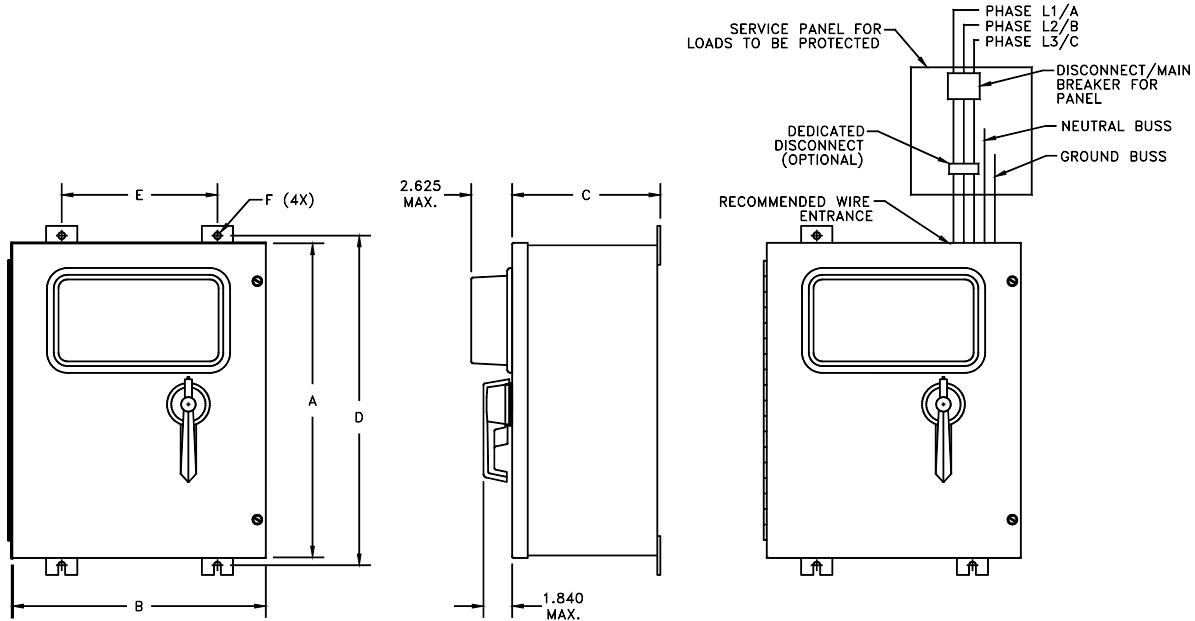

Surge Capacity	Suggested Breaker	Wire Range (AWG)	Dimensions (Inches)						Weight (lbs)
			A	B	C	D	E	F	
250	60 A	6 - 4	20	16	9	21.25	10.0	0.44	56
320	80 A	4 - 2	24	20	9	21.25	14.0	0.44	82
400	80 A	4 - 2	24	24	9	25.25	18.0	0.44	115
750	80 A	4 - 2	30	24	9	31.25	18.0	0.44	153

## AccuVar Series

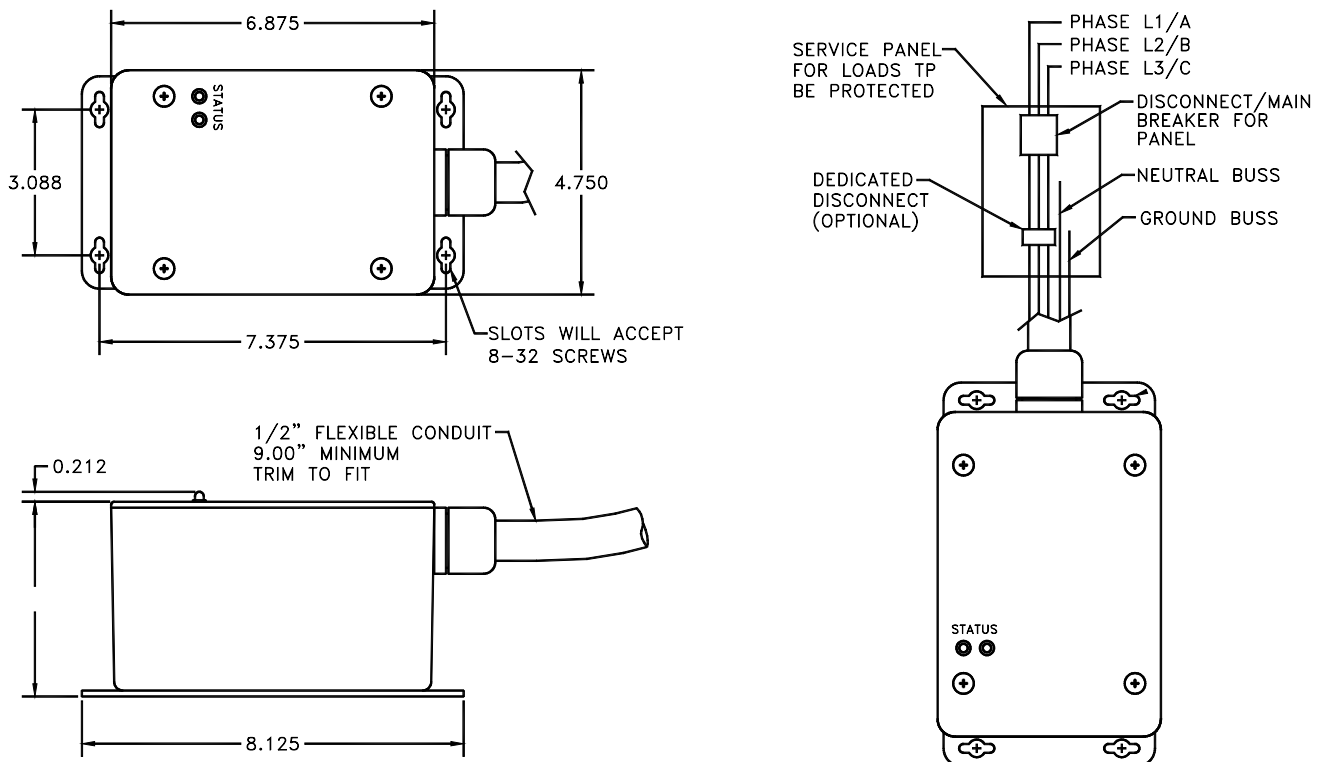

## Active Tracking Filter - Type ATF Series

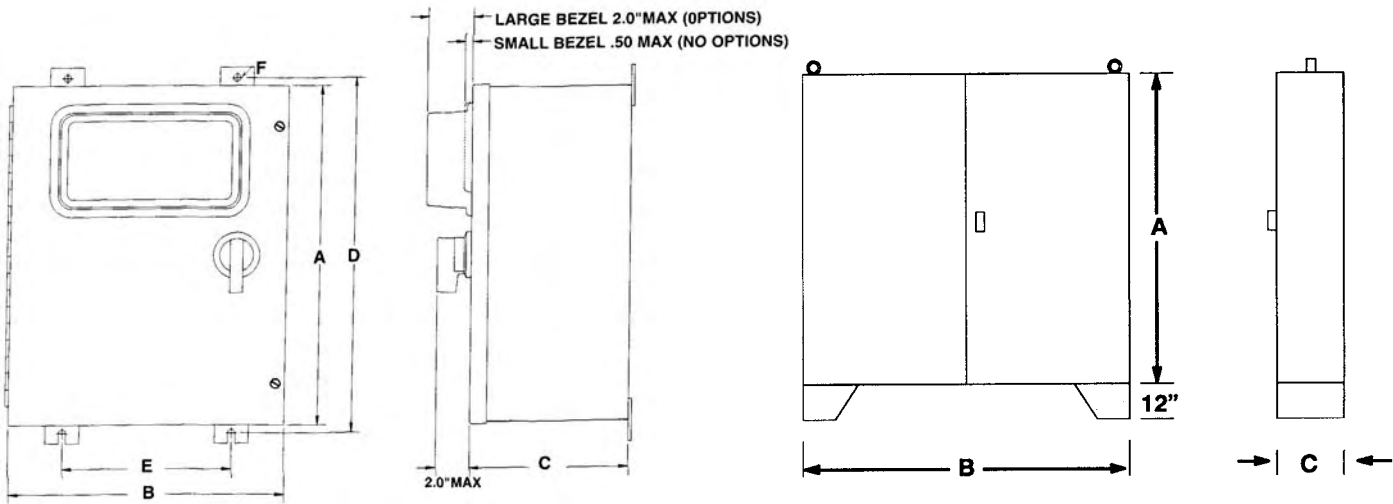

**Typical Cabinet Data (30 to 400Amps)**
**Typical Cabinet Data (800 to 4000Amps)**

Current Rating	Model XXX = VOLTAGE	Application	Dimensions (Inches)						Weight	
			A	B	C	D	E	F	Lbs	Kg
30A	FxxxN/L30	Single Phase	24.0	20.0	9.0	21.25	10.0	.44	35	15.9
	FxxxS30	Split Phase	24.0	20.0	9.0	25.25	14.0	.44	45	20.4
	FxxxD30	Three Phase Delta	24.0	20.0	9.0	25.25	14.0	.44	50	22.7
	FxxxY30	Three Phase Wye	24.0	20.0	9.0	25.25	14.0	.44	60	27.2
60A	FxxxN/L60	Single Phase	24.0	20.0	9.0	21.25	10.0	.44	35	15.9
	FxxxS60	Split Phase	24.0	20.0	9.0	25.25	14.0	.44	45	20.4
	FxxxD60	Three Phase Delta	24.0	20.0	9.0	25.25	14.0	.44	50	22.7
	FxxxY60	Three Phase Wye	24.0	20.0	9.0	25.25	14.0	.44	60	27.2
100A	FxxxN/L100	Single Phase	30.0	24.0	9.0	25.25	14.0	.44	60	27.2
	FxxxS100	Split Phase	30.0	24.0	9.0	31.25	18.0	.44	70	31.8
	FxxxD100	Three Phase Delta	30.0	24.0	9.0	31.25	18.0	.44	70	31.8
	FxxxY100	Three Phase Wye	30.0	24.0	9.0	31.25	18.0	.44	80	36.3
225A	FxxxN/L225	Single Phase L – N	30.0	24.0	9.0	25.25	14.0	.44	60	27.2
	FxxxS225	Split Phase	30.0	24.0	9.0	31.25	18.0	.44	70	31.8
	FxxxD225	Three Phase Delta	30.0	24.0	9.0	31.25	18.0	.44	70	31.8
	FxxxY225	Three Phase Wye	30.0	24.0	9.0	31.25	18.0	.44	80	36.3
400A	FxxxD400	Three Phase Delta	48.0	36.0	12.0	49.25	30.0	.44	275	125
	FxxxY400	Three Phase Wye	48.0	36.0	12.0	49.25	30.0	.44	300	136

Current Rating	Model XXX = VOLTAGE	Application	Dimensions (Inches)			Weight	
			A	B	C	Lbs	Kg
800A	FxxxD800 FxxxY800	Three Phase Delta	60.0	48.0	12.0	500	227
		Three Phase Wye	60.0	48.0	12.0	530	241
1200A	FxxxD1200 FxxxY1200	Three Phase Delta	60.0	48.0	20.0	700	318
		Three Phase Wye	60.0	48.0	20.0	750	340
2000A	FxxxD2000 FxxxY2000	Three Phase Delta	60.0	48.0	20.0	875	397
		Three Phase Wye	60.0	48.0	20.0	950	431
4000A	FxxxD4000 FxxxY4000	Three Phase Delta	60.0	48.0	20.0	1175	533
		Three Phase Wye	60.0	48.0	20.0	1300	590

NOTE: Consult factory for special instructions on caseless and switchgear models.

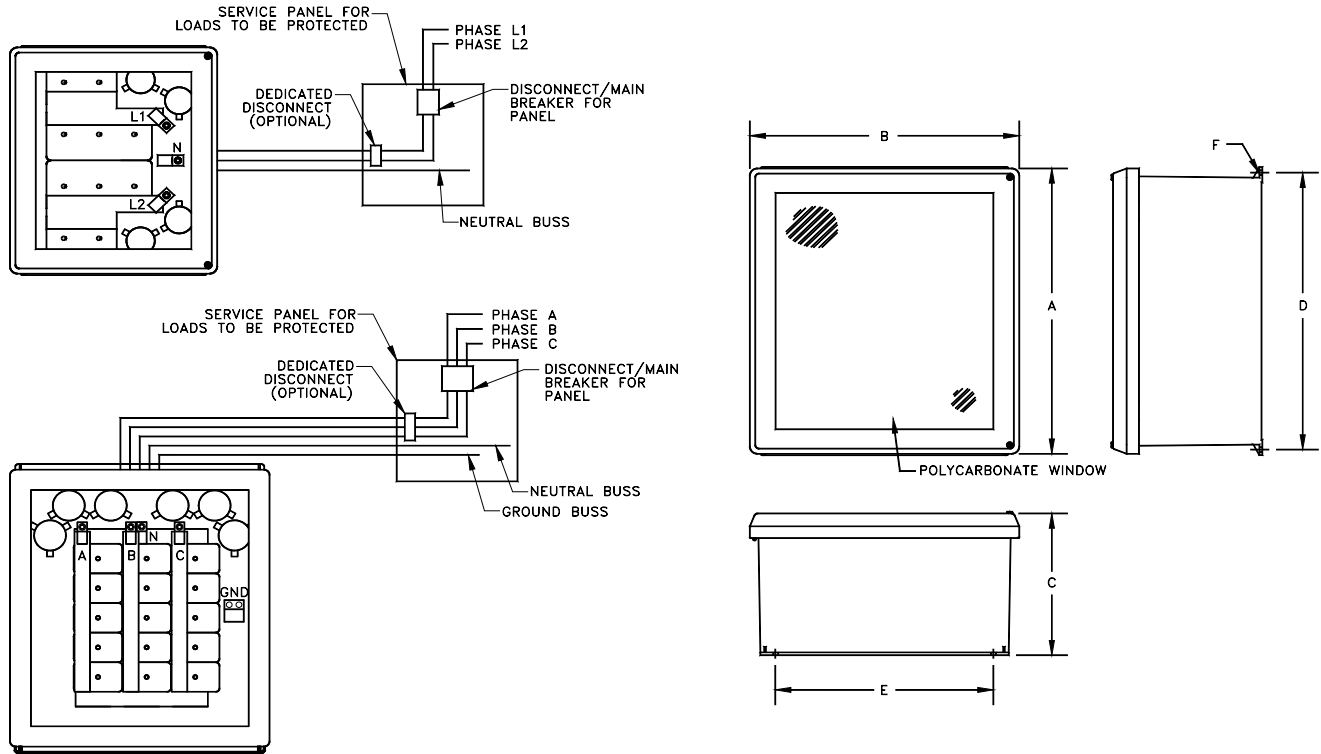
### Type SS Series



Voltage Source	Suggested Breaker	Wire Range (AWG)	Dimensions (Inches)						Weight (lbs)
			A	B	C	D	E	F	
Split Phase	60 A	6 - 4	15.32	13.32	6.6	14.75	10.0	0.32	26
Three Phase	60 A	6 - 4	19.32	17.32	9.6	18.75	12.0	0.32	43

### Type LM Series

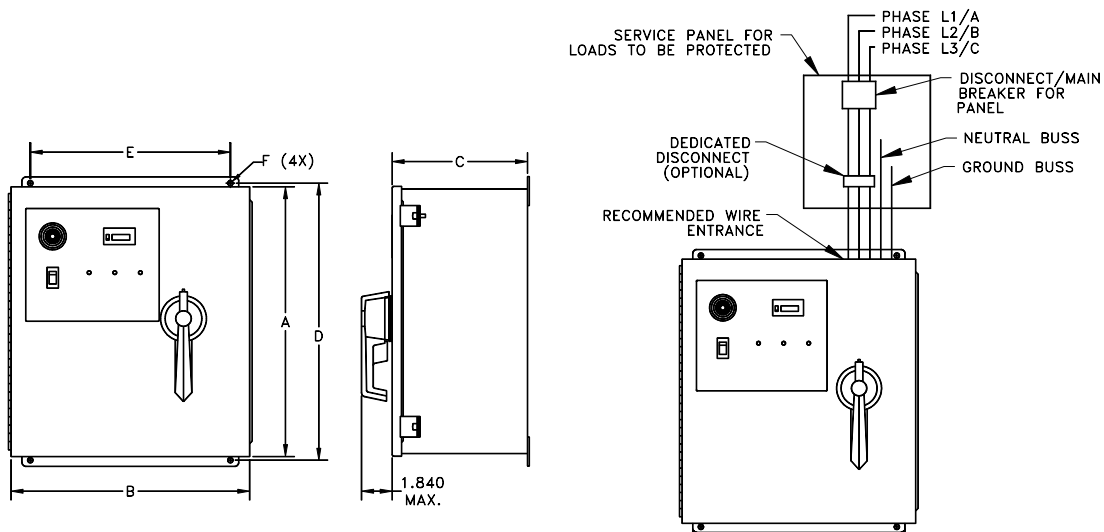

Surge Capacity	Suggested Breaker	Wire Range (AWG)	Dimensions (Inches)						Weight (lbs)
			A	B	C	D	E	F	
060-080	40 A	8 - 6	16	14	8	16.75	12.0	0.31	32
100-125	40 A	8 - 6	16	14	8	16.75	12.0	0.31	41
150	80 A	4 - 2	16	14	8	16.75	12.0	0.31	41
200-250	100 A	4 - 2	20	16	9	21.25	10	0.44	56

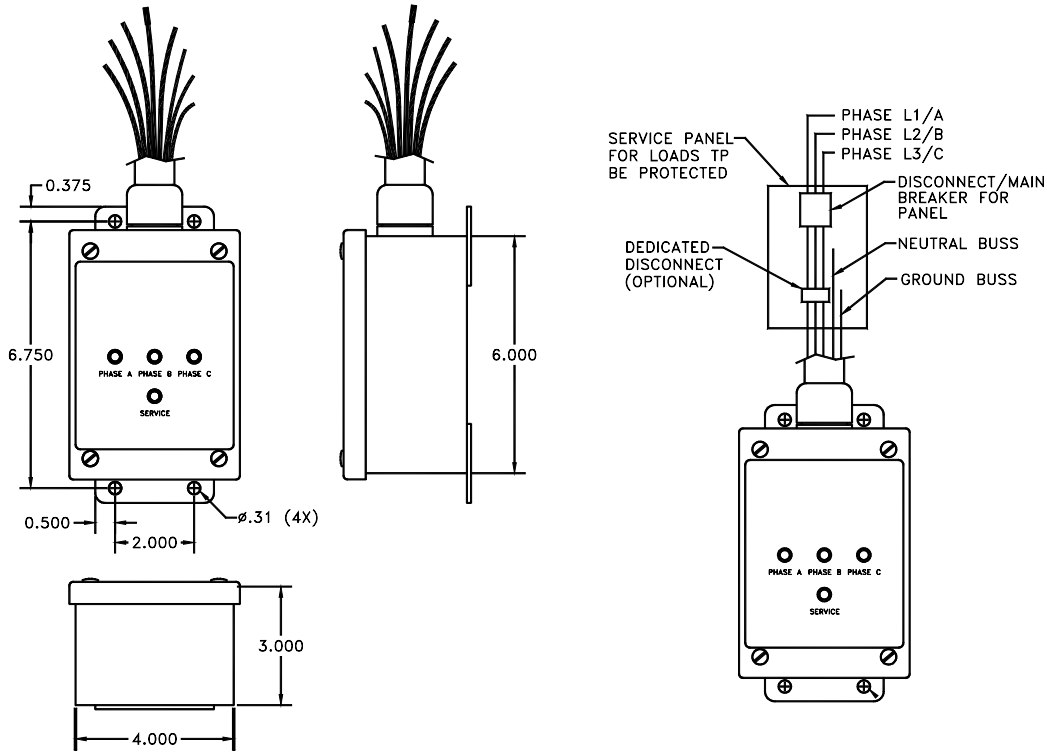
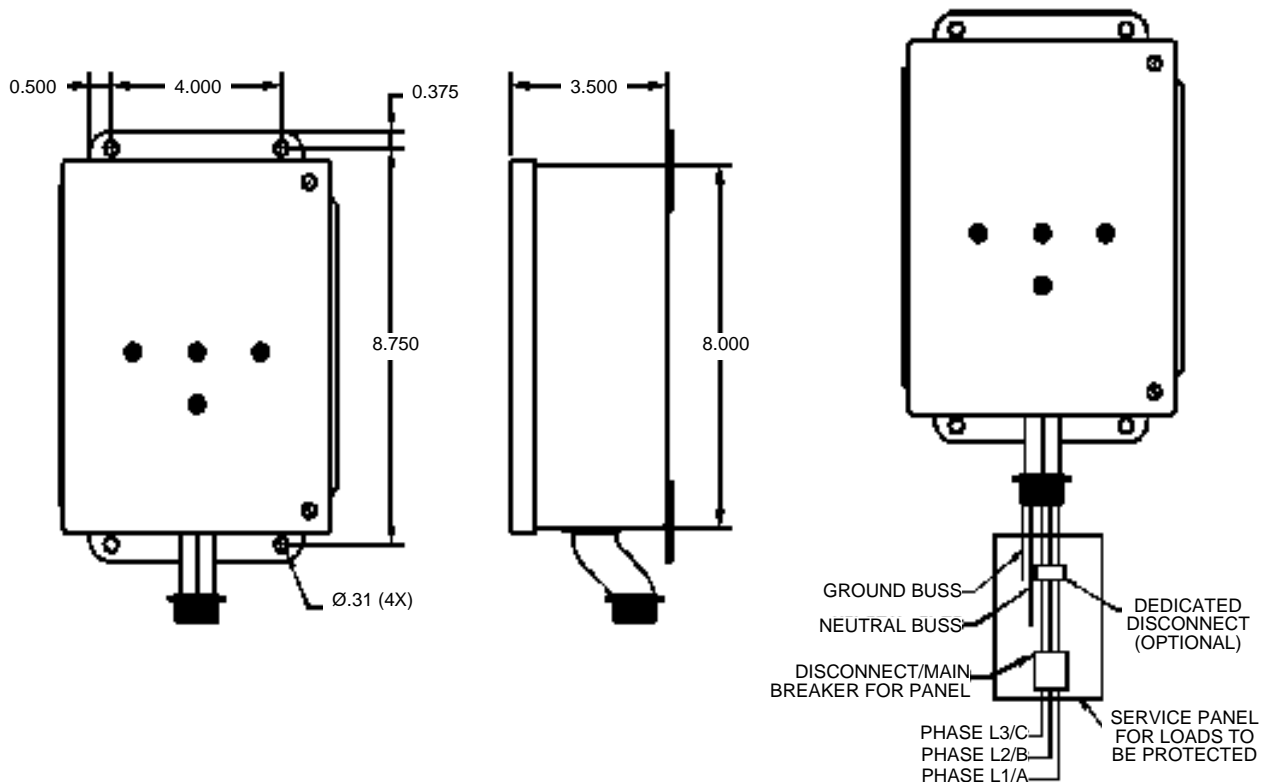
**PowerSure Medium Exposure - Type LPM 100-2 Series**

**PowerSure Medium Exposure - Type LPM 160 Series**

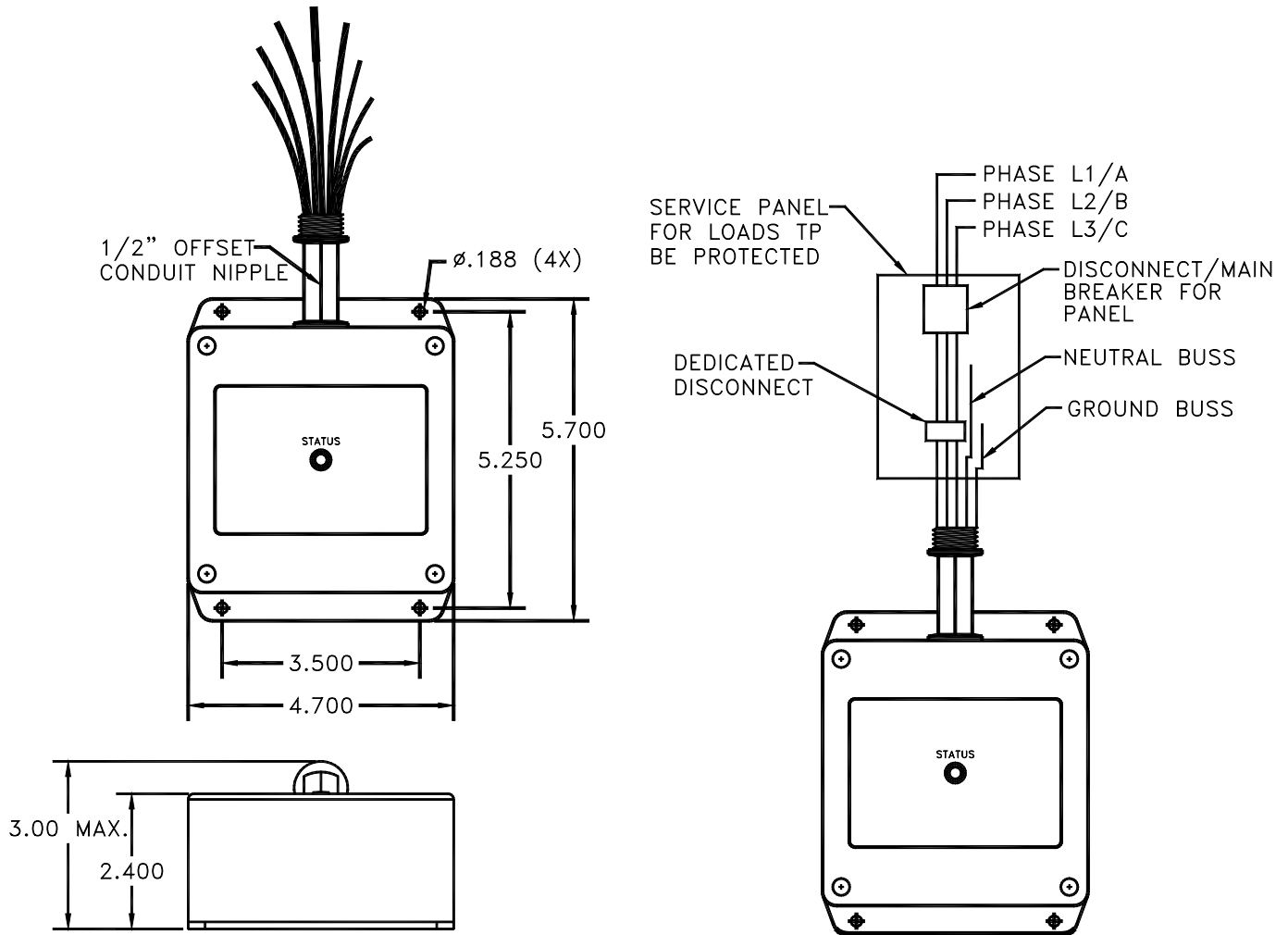
## PowerSure Low Exposure - Type LPL Series

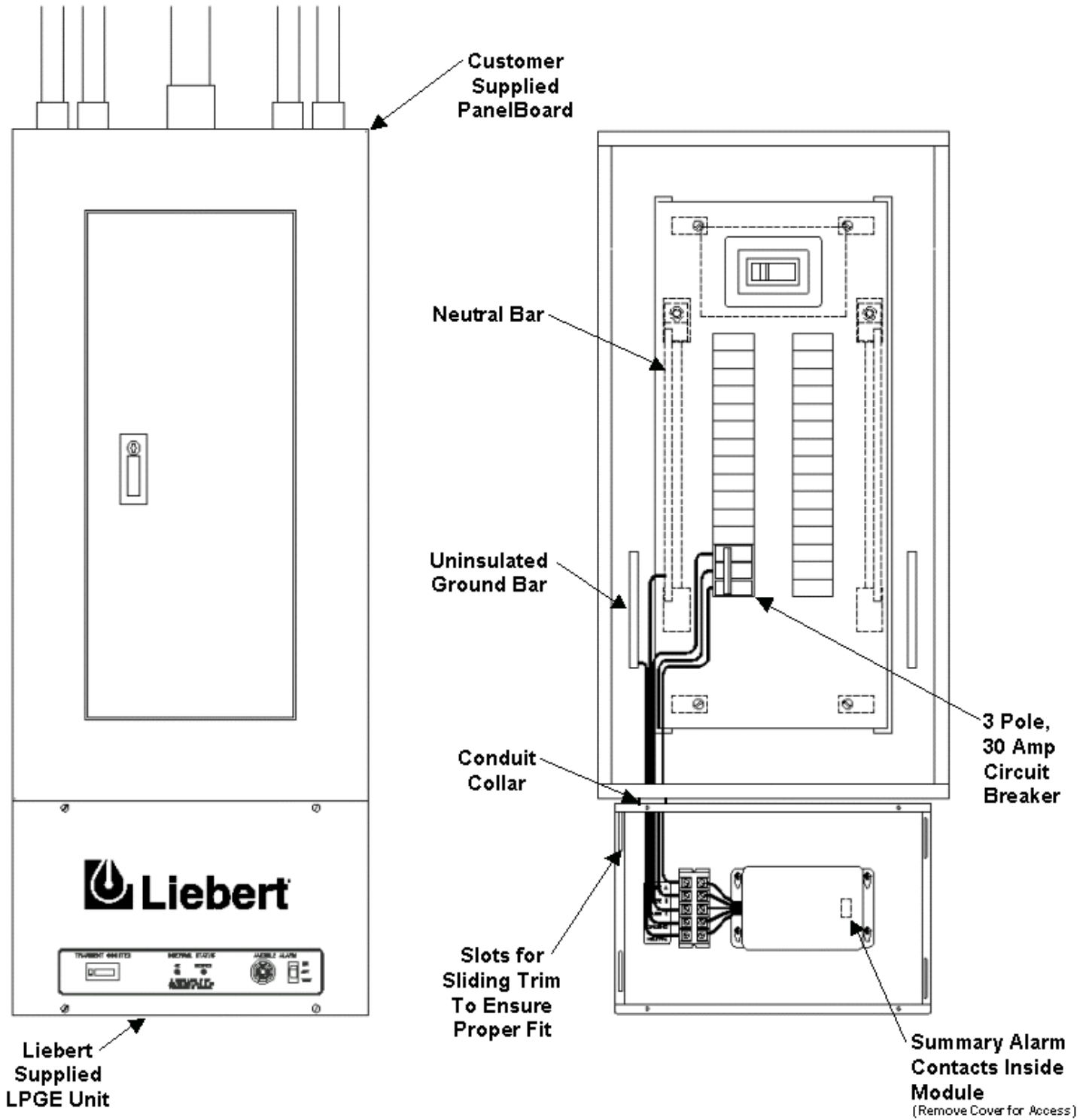

### Type LPGE Series



### Example Installations

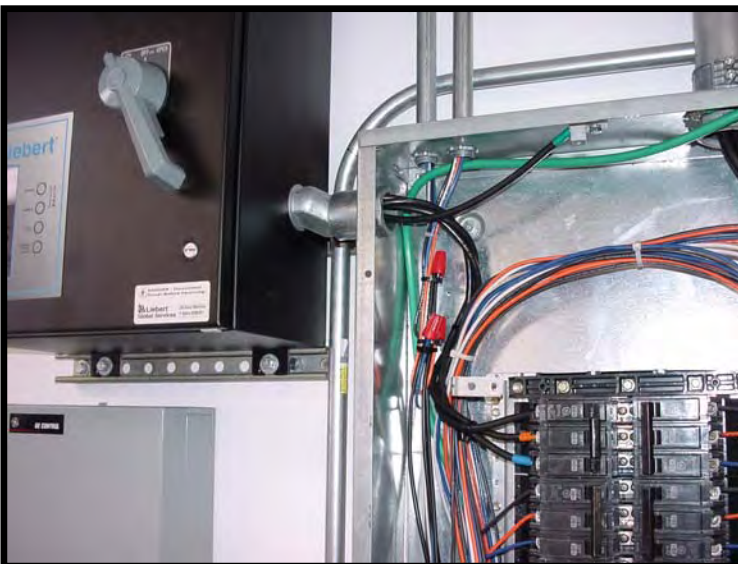
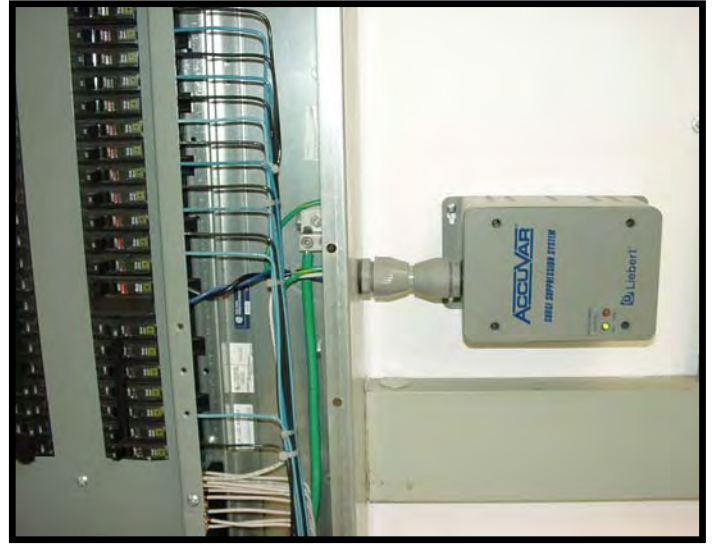
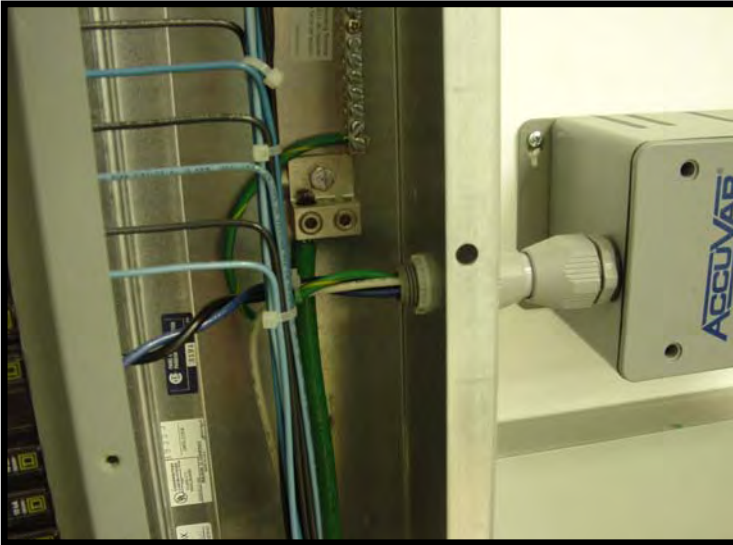

**LIMITED WARRANTY**

This Warranty is given **ONLY** to purchasers who buy for commercial or industrial use in the ordinary course of each purchaser's business.

**General:**

Liebert Corporation products and systems are in our opinion the finest available. We take pride in our products and are pleased that you have chosen them. Under certain circumstances we offer with our products the following Ten Year Warranty Against Defects in Material and Workmanship.

Please read your Warranty carefully. This Warranty sets forth our responsibilities in the unlikely event of defect and tells you how to obtain performance under this Warranty.

**TEN YEAR LIMITED WARRANTY AGAINST DEFECTS IN MATERIAL AND WORKMANSHIP****LIEBERT PRODUCTS COVERED:**

Interceptor<sup>®</sup> Transient Voltage Surge Suppressors, Interceptor Active Tracking<sup>®</sup> Filters, Hybrid Advantage Transient Voltage Surge Suppressors and Accuvar<sup>®</sup> Transient Voltage Surge Suppressors.

**Terms of Warranty:**

As provided herein, the Liebert product is warranted to be free of defects in material and workmanship for a period of ten (10) years from the date of product shipment from Liebert. The shipment date will be determined only from the Liebert bill of lading. If any part or portion of the Liebert product fails to conform to the warranty within the warranty period, Liebert, at its option, will furnish new or factory remanufactured parts for repair or replacement of that part or portion.

**Warranty Extends to First Purchaser for Use, Non-transferable:**

This Warranty is extended to the first person, firm, association or corporation for whom the Liebert product specified herein is originally installed for use (the "User") in the fifty United States (excluding territories) or Canada. This Warranty is not transferable or assignable without the prior written permission of Liebert.

**Assignment of Warranties:**

Liebert assigns to User any warranties which are made by manufacturers and suppliers of components of the Liebert product and which are assignable, but Liebert makes **NO REPRESENTATIONS** as to the effectiveness or extent of such warranties, assumes **NO RESPONSIBILITY** for any matters which may be warranted by such manufacturers or suppliers and extends no coverage under this warranty to such components.

**Drawings, Descriptions:**

Liebert warrants for the period and on the terms of the Warranty set forth herein that the Liebert product will conform to the certified drawings, if any, applicable thereto, to Liebert's final invoices, and to applicable Liebert product brochures and manuals current as of the date of product shipment ("Descriptions"). Liebert does not control the installation and use of any Liebert product. Accordingly, it is understood that the Descriptions are **NOT WARRANTIES OF PERFORMANCE** and **NOT WARRANTIES OF FITNESS FOR A PARTICULAR PURPOSE**.

**Obtaining Performance Under This Warranty:**

Within a reasonable time, but in no case to exceed thirty (30) days, after User's discovery of a defect, User shall contact Liebert at 1-800-LIEBERT (543-2378) and request a return authorization number. User shall ship the product, with proof of purchase, to Liebert freight prepaid. Liebert products shipped to Liebert without a return authorization number will be refused and returned freight collect to User at User's expense. Liebert products shipped by User to Liebert which have incurred freight damage due to User's improper packaging of the product will not be covered by this Warranty and any repairs or replacement parts, components or products needed will be invoiced in the full current price amount and returned freight collect to User.

Subject to the limitations specified herein, Liebert will repair or replace, at its option, without charge for Liebert labor or materials, subsequent to its inspection and F.O.B. Liebert's facility, the Liebert product warranted hereunder which does not conform to the Warranty. Replacement parts, components or products shipped to User prior to Liebert's receipt and inspection of the product claimed to be defective shall be invoiced in the full current price amount and shipped freight collect F.O.B. Liebert's facility. Warranty coverage will be extended only after Liebert's receipt of the claimed defective product within thirty (30) days of shipment of any replacement parts, components or products, if applicable, and only if Liebert's inspection discloses the claimed defect and the returned product shows no signs of treatment or use which would void the coverage of this Warranty. All defective products and component parts replaced under this Warranty become the property of Liebert.

**Warranty Performance of Component Manufacturers:**

It is Liebert's practice, consistent with its desire to remedy Warranty defects in the most prompt and effective manner possible, to cooperate with and utilize the services of component manufacturers and their authorized representatives in the performance of work to correct defects in the product components. Accordingly, Liebert may utilize third parties in the performance of Warranty work, including repair or replacement hereunder, where, in Liebert's opinion, such work can be performed in less time, with less expense, or in closer proximity to the Liebert product.

**Items Not Covered By Warranty:**

THIS WARRANTY DOES NOT COVER DAMAGE OR DEFECT CAUSED BY misuse, improper application, wrong or inadequate electrical current or connection, negligence, inappropriate on site operating conditions, corrosive atmosphere, repair by non-Liebert designated personnel, accident in transit, tampering, alterations, a change in location or operating use, exposure to the elements, Acts of God, theft or installation contrary to Liebert's recommendations or specifications, or in any event if the Liebert serial number has been altered, defaced or removed. Notwithstanding the foregoing, the following Acts of God are covered: lightning-induced surges, which are transients, spikes or other sub-cycle, discontinuous events impinging on normally applied voltage as defined by reference data in the latest version of IEEE C62.41 and the Liebert product performance specifications.

THIS WARRANTY DOES NOT COVER shipping costs, installation costs, circuit breaker resetting or maintenance or service items and further, except as provided herein, does NOT include labor costs or transportation charges arising from the replacement of the Liebert product or any part thereof or charges to remove or reinstall same at any premises of the User.

THIS WARRANTY DOES NOT COVER DAMAGE OR DEFECT CAUSED BY use of the Liebert product in combination with any electrical or electronic components, circuits, systems, assemblies, or other materials not furnished by Liebert. Liebert does NOT warrant the suitability for use or the results of the Liebert product in combination with the products of others.

THE PRODUCTS LISTED IN THIS WARRANTY ARE NOT DESIGNED FOR USE IN THE FOLLOWING APPLICATIONS: (i) ANY NUCLEAR OR RELATED APPLICATIONS; AND (ii) LIFE SUPPORT AND PATIENT-CONNECTED AND APPLIED MEDICAL AND DENTAL APPLICATIONS.

REPAIR OR REPLACEMENT OF A DEFECTIVE PRODUCT OR PART THEREOF DOES NOT EXTEND THE ORIGINAL WARRANTY PERIOD.

**Limitations:**

- THIS WARRANTY IS IN LIEU OF AND EXCLUDES ALL OTHER WARRANTIES, EXPRESS OR IMPLIED, INCLUDING MERCHANTABILITY AND FITNESS FOR A PARTICULAR PURPOSE.
- USER'S SOLE AND EXCLUSIVE REMEDY IS REPAIR OR REPLACEMENT OF THE LIEBERT PRODUCT AS SET FORTH HEREIN.
- IF USER'S REMEDY IS DEEMED TO FAIL OF ITS ESSENTIAL PURPOSE BY A COURT OF COMPETENT JURISDICTION, LIEBERT'S RESPONSIBILITY FOR PROPERTY LOSS OR DAMAGE SHALL NOT EXCEED THE NET PRODUCT PURCHASE PRICE.
- IN NO EVENT SHALL LIEBERT ASSUME ANY LIABILITY FOR INDIRECT, SPECIAL, INCIDENTAL, OR CONSEQUENTIAL DAMAGES OF ANY KIND WHATSOEVER, INCLUDING WITHOUT LIMITATION, LOST PROFITS, BUSINESS INTERRUPTION OR LOSS OF DATA, WHETHER ANY CLAIM IS BASED UPON THEORIES OF CONTRACT, NEGLIGENCE, STRICT LIABILITY, TORT OR OTHERWISE.

**Miscellaneous:**

- NO SALESPERSON, EMPLOYEE OR AGENT OF LIEBERT IS AUTHORIZED TO ADD TO OR VARY THE TERMS OF THIS WARRANTY. Warranty terms may be modified, if at all, only in a writing signed by a Liebert officer.
- Liebert obligations under this warranty are conditioned upon Liebert timely receipt of full payment of the product purchase price and any other amounts due. Liebert reserves the right to supplement or change the terms of this Warranty in any subsequent warranty offering to User or others.
- In the event that any provision of this Warranty should be or becomes invalid and/or unenforceable during the warranty period, the remaining terms and provisions shall continue in full force and effect.
- This Warranty shall be governed by, and construed under, the laws of the State of Ohio, without reference to the conflict of laws principles thereof.
- This Warranty represents the entire agreement between Liebert and User with respect to the subject matter herein and supersedes all prior or contemporaneous oral or written communications, representations, understandings or agreements relating to this subject.

**LIMITED WARRANTY**

This Warranty is given **ONLY** to purchasers who buy for commercial or industrial use in the ordinary course of each purchaser's business.

**General:**

Liebert Corporation products and systems are in our opinion the finest available. We take pride in our products and are pleased that you have chosen them. Under certain circumstances we offer with our products the following Five Year Warranty Against Defects in Material and Workmanship.

Please read your Warranty carefully. This Warranty sets forth our responsibilities in the unlikely event of defect and tells you how to obtain performance under this Warranty.

**FIVE YEAR LIMITED WARRANTY AGAINST DEFECTS IN MATERIAL AND WORKMANSHIP****LIEBERT PRODUCTS COVERED:**

Panelguard Extension, LM Series Transient Voltage Surge Suppressors, Accuguide<sup>®</sup> Cable, and PowerSure Panel Transient Voltage Surge Suppressors.

**Terms of Warranty:**

As provided herein, the Liebert product is warranted to be free of defects in material and workmanship for a period of five (5) years from the date of product shipment from Liebert. The shipment date will be determined only from the Liebert bill of lading. If any part or portion of the Liebert product fails to conform to the warranty within the warranty period, Liebert, at its option, will furnish new or factory remanufactured parts for repair or replacement of that part or portion.

**Warranty Extends to First Purchaser for Use, Non-transferable:**

This Warranty is extended to the first person, firm, association or corporation for whom the Liebert product specified herein is originally installed for use (the "User") in the fifty United States or Canada. This Warranty is not transferable or assignable without the prior written permission of Liebert.

**Assignment of Warranties:**

Liebert assigns to User any warranties which are made by manufacturers and suppliers of components of the Liebert product and which are assignable, but Liebert makes **NO REPRESENTATIONS** as to the effectiveness or extent of such warranties, assumes **NO RESPONSIBILITY** for any matters which may be warranted by such manufacturers or suppliers and extends no coverage under this warranty to such components.

**Drawings, Descriptions:**

Liebert warrants for the period and on the terms of the Warranty set forth herein that the Liebert product will conform to the certified drawings, if any, applicable thereto, to Liebert's final invoices, and to applicable Liebert product brochures and manuals current as of the date of product shipment ("Descriptions"). Liebert does not control the installation and use of any Liebert product. Accordingly, it is understood that the Descriptions are **NOT WARRANTIES OF PERFORMANCE** and **NOT WARRANTIES OF FITNESS FOR A PARTICULAR PURPOSE**.

**Obtaining Performance Under This Warranty:**

Within a reasonable time, but in no case to exceed thirty (30) days, after User's discovery of a defect, User shall contact Liebert at 1-800-LIEBERT (543-2378) and request a return authorization number. User shall ship the product, with proof of purchase, to Liebert freight prepaid. Liebert products shipped to Liebert without a return authorization number will be refused and returned freight collect to User at User's expense. Liebert products shipped by User to Liebert which have incurred freight damage due to User's improper packaging of the product will not be covered by this Warranty and any repairs or replacement parts, components or products needed will be invoiced in the full current price amount and returned freight collect to User.

Subject to the limitations specified herein, Liebert will repair or replace, at its option, without charge for Liebert labor or materials, subsequent to its inspection and F.O.B. Liebert's facility, the Liebert product that does not conform to the Warranty. Replacement parts, components or products shipped to User prior to Liebert's receipt and inspection of the product claimed to be defective shall be invoiced in the full current price amount and shipped freight collect F.O.B. Liebert's facility. Warranty coverage will be extended only after Liebert's receipt of the claimed defective product within thirty (30) days of shipment of any replacement parts, components or products, if applicable, and only if Liebert's inspection discloses the claimed defect and the returned product shows no signs of treatment or use which would void the coverage of this Warranty. All defective products and component parts replaced under this Warranty become the property of Liebert.

**Warranty Performance of Component Manufacturers:**

It is Liebert's practice, consistent with its desire to remedy Warranty defects in the most prompt and effective manner possible, to cooperate with and utilize the services of component manufacturers and their authorized representatives in the performance of work to correct defects in the product components. Accordingly, Liebert may utilize third parties in the performance of Warranty work, including repair or replacement hereunder, where, in Liebert's opinion, such work can be performed in less time, with less expense, or in closer proximity to the Liebert product.

**Items Not Covered By Warranty:**

THIS WARRANTY DOES NOT COVER DAMAGE OR DEFECT CAUSED BY misuse, improper application, wrong or inadequate electrical current or connection, negligence, inappropriate on site operating conditions, corrosive atmosphere, repair by non-Liebert designated personnel, accident in transit, tampering, alterations, a change in location or operating use, exposure to the elements, Acts of God, theft or installation contrary to Liebert's recommendations or specifications, or in any event if the Liebert serial number has been altered, defaced or removed. Notwithstanding the foregoing, the following Acts of God are covered: lightning-induced surges, which are transients, spikes or other sub-cycle, discontinuous events impinging on normally applied voltage as defined by reference data in the latest version of IEEE C62.41 and the Liebert product performance specifications.

THIS WARRANTY DOES NOT COVER shipping costs, installation costs, circuit breaker resetting or maintenance or service items and further, except as provided herein, does NOT include labor costs or transportation charges arising from the replacement of the Liebert product or any part thereof or charges to remove or reinstall same at any premises of the User.

THIS WARRANTY DOES NOT COVER DAMAGE OR DEFECT CAUSED BY use of the Liebert product in combination with any electrical or electronic components, circuits, systems, assemblies, or other materials not furnished by Liebert. Liebert does NOT warrant the suitability for use or the results of the Liebert product in combination with the products of others.

THE PRODUCTS LISTED IN THIS WARRANTY ARE NOT DESIGNED FOR USE IN THE FOLLOWING APPLICATIONS: (i) ANY NUCLEAR OR RELATED APPLICATIONS; AND (ii) LIFE SUPPORT AND PATIENT-CONNECTED AND APPLIED MEDICAL AND DENTAL APPLICATIONS.

REPAIR OR REPLACEMENT OF A DEFECTIVE PRODUCT OR PART THEREOF DOES NOT EXTEND THE ORIGINAL WARRANTY PERIOD.

**Limitations:**

- THIS WARRANTY IS IN LIEU OF AND EXCLUDES ALL OTHER WARRANTIES, EXPRESS OR IMPLIED, INCLUDING MERCHANTABILITY AND FITNESS FOR A PARTICULAR PURPOSE.
- USER'S SOLE AND EXCLUSIVE REMEDY IS REPAIR OR REPLACEMENT OF THE LIEBERT PRODUCT AS SET FORTH HEREIN.
- IF USER'S REMEDY IS DEEMED TO FAIL OF ITS ESSENTIAL PURPOSE BY A COURT OF COMPETENT JURISDICTION, LIEBERT'S RESPONSIBILITY FOR PROPERTY LOSS OR DAMAGE SHALL NOT EXCEED THE NET PRODUCT PURCHASE PRICE.
- IN NO EVENT SHALL LIEBERT ASSUME ANY LIABILITY FOR INDIRECT, SPECIAL, INCIDENTAL, OR CONSEQUENTIAL DAMAGES OF ANY KIND WHATSOEVER, INCLUDING WITHOUT LIMITATION, LOST PROFITS, BUSINESS INTERRUPTION OR LOSS OF DATA, WHETHER ANY CLAIM IS BASED UPON THEORIES OF CONTRACT, NEGLIGENCE, STRICT LIABILITY, TORT OR OTHERWISE.

**Miscellaneous:**

- NO SALESPERSON, EMPLOYEE OR AGENT OF LIEBERT IS AUTHORIZED TO ADD TO OR VARY THE TERMS OF THIS WARRANTY. Warranty terms may be modified, if at all, only in a writing signed by a Liebert officer.
- Liebert obligations under this warranty are conditioned upon Liebert timely receipt of full payment of the product purchase price and any other amounts due. Liebert reserves the right to supplement or change the terms of this Warranty in any subsequent warranty offering to User or others.
- In the event that any provision of this Warranty should be or becomes invalid and/or unenforceable during the warranty period, the remaining terms and provisions shall continue in full force and effect.
- This Warranty shall be governed by, and construed under, the laws of the State of Ohio, without reference to the conflict of laws principles thereof.
- This Warranty represents the entire agreement between Liebert and User with respect to the subject matter herein and supersedes all prior or contemporaneous oral or written communications, representations, understandings or agreements relating to this subject.



**POWER PROTECTION**