

■ Solar Power Systems
for *Business-Critical Continuity*[™]

SunnySure[™] Solar Power Solution for Telecommunication



SunnySure™ Solar Power Solution for Telecommunication

Application scope:

- Communication sites, Mobile base stations
- Microwave relay stations and transmission relay stations
- Military, Electrical Power and Railway stations

Features:

- **Green and energy-saving**
- **Pollution reduction:** Reduce the discharge of 170 tons of carbon dioxide each year
- **Applicable for the rural area without utility power supply:** Increase the coverage of communication signals
- **Less maintenance efforts:** Reduce maintenance cost
- **Long life:** Long life solar power controller and photovoltaic cells

Features:

- **Green and energy-saving:** Can save 30% energy consumption
- **Pollution reduction:** Reduce the discharge of more than 50 tons of carbon dioxide each year
- **Integration of multi energy supplies:** Reduce investment cost
- **Avoid peak electricity billing time:** Improve the reliability of power supply and reduce the operation cost in the same time
- **High reliability:** Reduce the battery discharging times and discharging depth, and prolong the battery life

Emerson Network Power Solar Power Solution, utilizing cutting edge solar/electrical conversion control technology, provides energy-saving and environmental friendly integrated power supply with energy sources such as wind, solar power, and diesel generator.

The innovated solution, regarded as the green site, uses optimized hardware design, charging control technology and power consumption management to help operators realize a high level of power saving. Every 10,000 sites can save up to 170 millions kWh energy each year and reduce the discharge of 1.7 million tons of carbon dioxide each year based on the assumption for 2KW site.

SunnySure™ Independent Solar Power System

Solar panel + Solar controller + Batteries

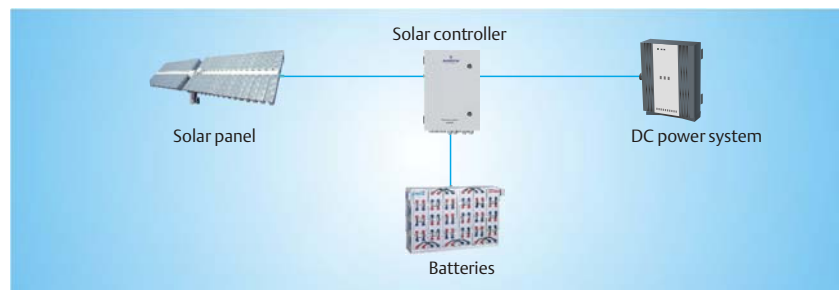

SunnySure™ Hybrid Solution

Solar panel + Diesel generator + Utility Power + Solar controller + Batteries

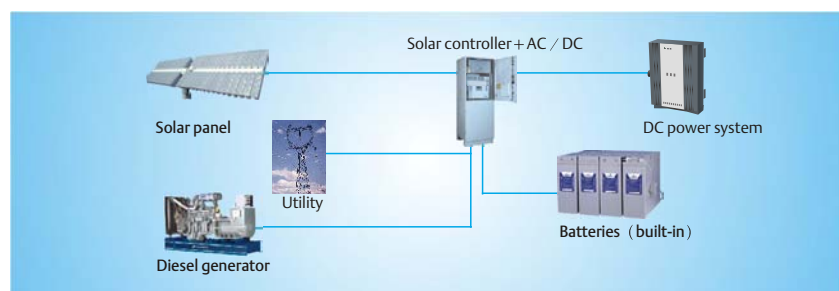
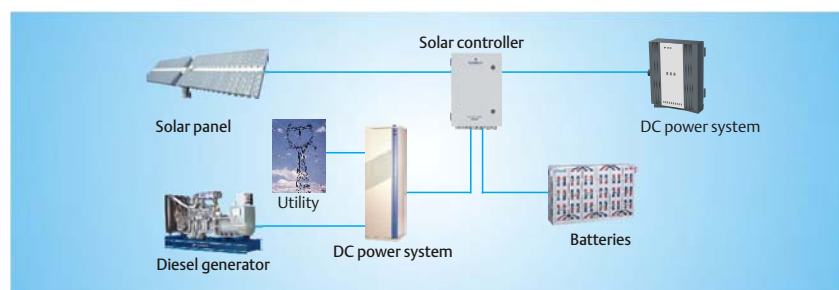

SunnySure™ Solar Power Solution for Telecommunication

SunnySure™ Solar Power + Wind Power Solution

Solar panel + wind power generator + solar controller + batteries

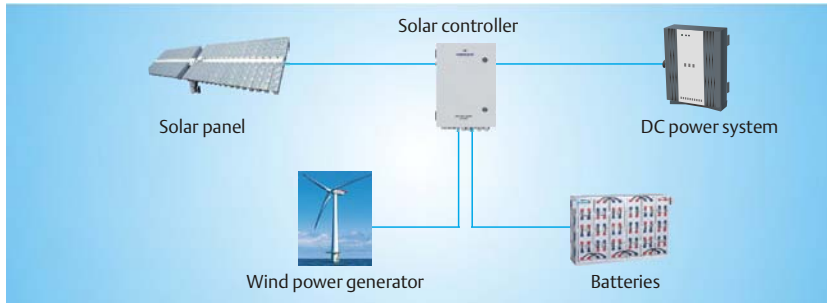

SunnySure™ Solar Power + Wind Power + Utility Power Solution

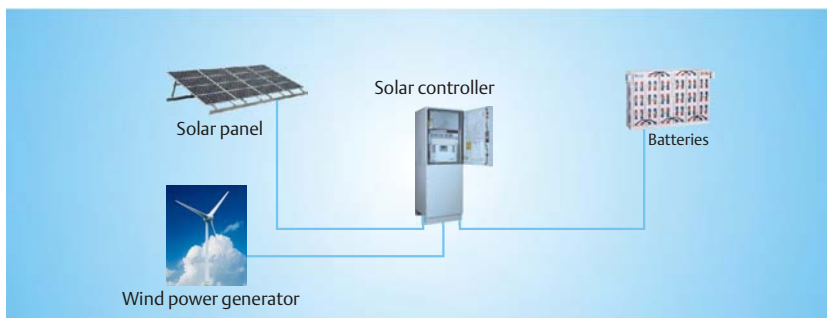
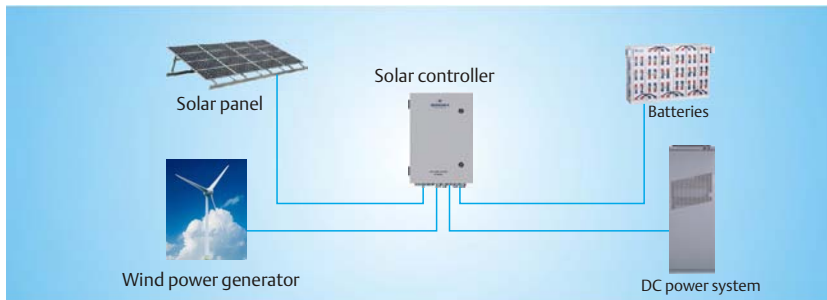

Features:

- **Green and energy-saving:** 100% energy consumption comes from green energy
- **Pollution reduction:** Reduce the discharge of more than 170 tons of carbon dioxide each year
- **Integration of multi energy supplies:** Reduce the investment cost and improve the reliability
- **High adaptability:** Flexible configuration according to the different wind and solar energy resources in different regions
- **High reliability:** Reduce the battery discharging depth thus prolong the battery life cycle

Features:

- **Green and energy-saving:** Can save more than 50% energy consumption
- **Pollution reduction:** Reduce the discharge of more than 75 tons of carbon dioxide each year
- **High reliability:** Use utility power supply as backup to reduce the chance of operation interruption
- **Integration of multi energy supplies:** Utilize the natural resources as much as possible
- **High adaptability:** Flexible configuration according to the different wind, solar energy and utility power supply resources in different regions
- **Battery configuration:** Reduce the investment, and prolong the battery life



SunnySure™ Solar Power Controller

Emerson Solar Controller is the core for the Solar Power System. The main functions include: switching control of solar panel, connection control of wind power generator and diesel generator, battery charging / discharging management, man-machine operating interface and equipment status monitoring.

Emerson solar power controller is an intelligent remote control unit for the system. The high reliability and adaptability depends on charging control technology without power loss. The system MTBF reaches 500,000 hours and the service life is up to 15 years.

Features

- Perfect battery charging / discharging management
- Multi patented technologies on solar power panel management
- Various power system available according to different energy supplies
- Loss-less charging control improves the system reliability and prolongs the system life cycle
- Current back-feed prevention function of the solar panel effectively prolong solar panel life
- Can record charging and discharging current and the amount of generated power every day, calculate the battery capacity in real time. Records of 31 days information could be stored
- Operation temperature range: -30℃ - 60℃
- 100 history alarm information can be recorded
- All the interfaces have lightning protection functions with built-in 40kVA SPD
- Provide both BLVD and LLVD
- Dual redundancy control realizes high reliability and convenience of maintenance

Functions of SunnySure™ Solar Power Controller

Connection / disconnection control of solar panel

- Connection / disconnection control of solar panel ensures the normal charging voltage and current for battery

Battery management

- Realize the conversion between float charging and boost charging according to the input voltage and current, battery capacity and load
- The over voltage and over current points are configurable; therefore protected the main equipment and battery effectively

Protection

- Current back-feed prevention function for solar panel
- Over current, over voltage and over temperature protection functions are used to improve system reliability

Temperature compensation

- Intelligent compensation according to the ambient temperature change

Supervision/Monitoring functions

- Multi-language display with large size high brightness LCD, user-friendly interface
- Real time calendar
- Can connect to centralize monitoring center through RS485 / RS232 / CAN bus easily
- Battery charging / discharging and capacity recording function
- Optional manual / auto control functions to realize remote testing, monitoring, communication and configuration
- Optional GPRS / GSM dual module enables real time information on hand

Alarm functions

- System fault can be detected and reported to the host computer
- Alarm for solar panel failure and loss
- 100 PCS of history alarm records can be recorded
- 6 auxiliary alarm relay outputs and 3 auxiliary alarm relay inputs

SunnySure™ Series Solar Controller

SunnySure™ Wall-mounted Solar Controller

- Flexible installation: can be wall-mounted or pole-mounted
- IP55 protection for outdoor application
- Front access and user-friendly menu interface

SunnySure™ Embedded Solar Power Controller

- 19-inch standard subrack design could be embedded in 19 inch cabinet
- Front access and user-friendly menu interface
- Diversity energy supply for different systems
- Neatly cabling by side access, more safe

SunnySure™ Integrated Power System and Controller

- Can integrate wind , solar and utility in one power system
- That solar power takes the priority realizes energy saving effectively and reduces the battery discharging times in the same time
- Small footprint and fast installation
- IP55 protection for outdoor application



SunnySure™ Solar Power Controller Series

Naming rules of SunnySure™ Series Solar Power Controller

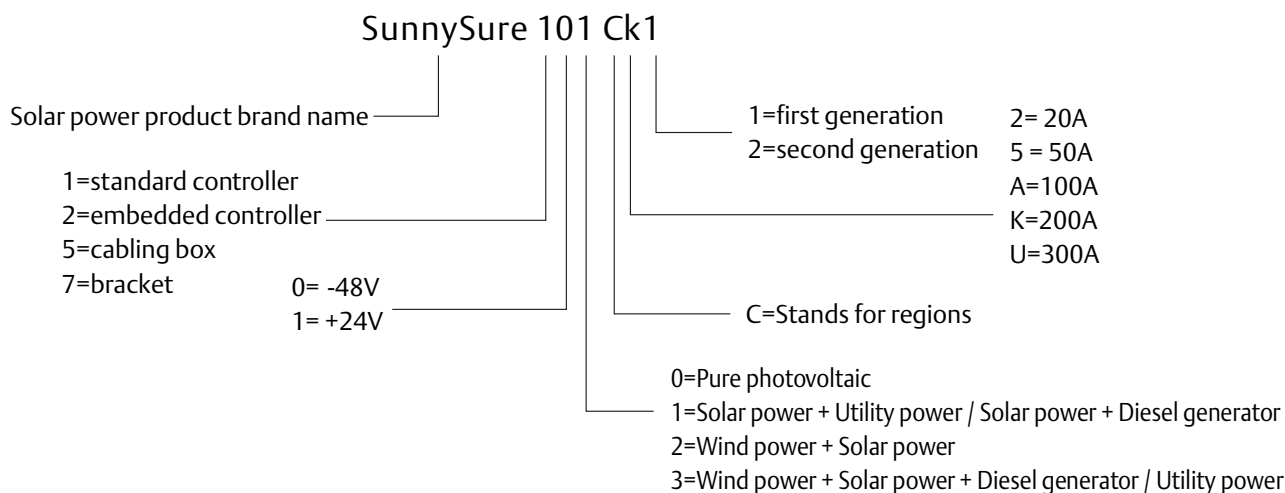

Specifications of SunnySure™ Wall-mounted Solar Power Controller

Model		SunnySure10(n)C21	SunnySure10(n)C51	SunnySure10(n)CA1	SunnySure10(n)CK1	SunnySure10(n)CU1
Input	Input rated voltage	48V	48V	48V	48V	48V
	n=0 Solar power input	16A×2	32A×2	63A×4	63A×4	63A×6
	n=1 Solar power input Utility power (Diesel generator)	16A×2	32A×2	63A×4	63A×4	63A×6
		16A×2	32A×2	63A×4	63A×4	63A×6
	n=2 Solar power input Wind power input	16A×2	32A×2	63A×4	63A×4	63A×6
		16A×2	32A×2	63A×4	63A×4	63A×6
	n=3 Solar power input Wind power input Utility power (Diesel generator)	16A×2	32A×2	63A×4	63A×4	63A×6
16A×2		32A×2	63A×4	63A×4	63A×6	
16A×2		32A×2	63A×4	63A×4	63A×6	
Output	Output rated voltage	48V	48V	48V	48V	48V
	Load current	10A	20A	30A	50A	100A
	Output circuit breaker	16A × 1	16A × 2	63A × 1	63A × 1	125A × 1
		32A × 2	32A × 2	32A × 1	32A × 1	63A × 1
	Efficiency	> 99.5%	> 99.5%	> 99.5%	> 99.5%	> 99.5%

Note: When n=0, it indicates independent solar power system; When n=1, it indicates solar power + utility power / solar power + diesel generator system
 When n=2, it indicates wind power + solar power system; When n=3, it indicates wind power + solar power + utility power system

Mechanical Parameters of SunnySure™ Wall-mounted Solar Power Controller

Parts	Dimensions H×W×D(mm)	Weight (Kg)
SunnySure10(n)C21	550×400×135	10Kg
SunnySure10(n)C51	580×420×140	14Kg
SunnySure10(n)CA1	620×480×182	17Kg
SunnySure10(n)CK1	620×480×182	20Kg
SunnySure10(n)CU1	620×480×182	22Kg

SunnySure™ Series Solar Power Controller

Specifications of SunnySure™ Embedded Solar Power Controller

Model		Sunnysure20(n)C21	Sunnysure20(n)C51	Sunnysure20(n)CA1	Sunnysure20(n)CK1	Sunnysure20(n)CU1	
Input	Input rated voltage	48V	48V	48V	48V	48V	
	n=0 Solar power input	16A×2	32A×2	63A×6	63A×4	63A×4	
	n=1 Solar power input Utility power (Diesel generator)	Solar power input	16A×2	32A×2	63A×6	63A×4	63A×4
		Utility power (Diesel generator)	16A×2	32A×2	63A×6	63A×4	63A×4
	n=2 Solar power input Wind power input	Solar power input	16A×2	32A×2	63A×6	63A×4	63A×4
		Wind power input	16A×2	32A×2	63A×6	63A×4	63A×4
	n=3 Solar power input Wind power input Utility power (Diesel generator)	Solar power input	16A×2	32A×2	63A×6	63A×4	63A×4
Wind power input		16A×2	32A×2	63A×6	63A×4	63A×4	
Utility power (Diesel generator)		16A×2	32A×2	63A×6	63A×4	63A×4	
Output	Output rated voltage	48V	48V	48V	48V	48V	
	Load current	10A	20A	30A	100A	50A	
	Output circuit breaker	LLVD	16A × 1	16A × 2	63A × 1	63A × 1	125A × 1
		BLVD	32A × 2	32A × 2	32A × 1 16A × 2	32A × 1 16A × 2	63A × 1 32A × 2
Efficiency	> 99.5%	> 99.5%	> 99.5%	> 99.5%	> 99.5%		

Note: When n=0, it indicates independent solar power system; When n=1, it indicates solar power + utility power / solar power + diesel generator system
When n=2, it indicates wind power + solar power system; When n=3, it indicates wind power + solar power + utility power system

Mechanical Parameters of SunnySure™ Embedded Solar Power Controller

Controller model	Dimensions H×W×D	Maximum Weight
SunnySure20(n)C21	436X300X263.9	8Kg
SunnySure20(n)C51	436X300X263.9	10Kg
SunnySure20(n)CA1	436X300X263.9	15Kg
SunnySure20(n)CK1	436X300X263.9	20Kg
SunnySure20(n)CU1	436X300X263.9	25Kg

Installation Dimensions of SunnySure™ Pole-mounted Solar Power Controller

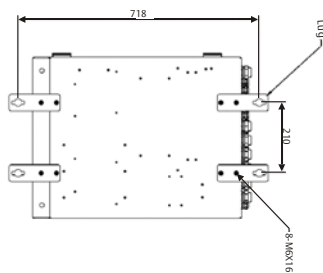

Installation Dimensions of SunnySure™ Wall-mounted Solar Power Controller

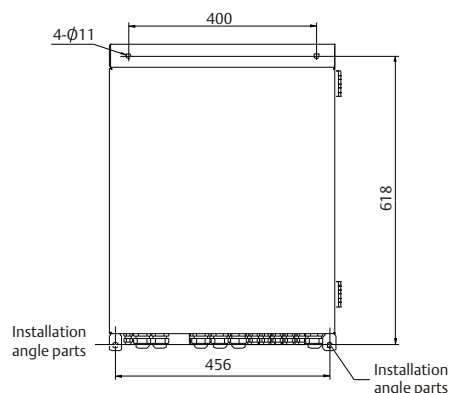

Installation Dimensions of SunnySure™ Embedded Solar Power Controller

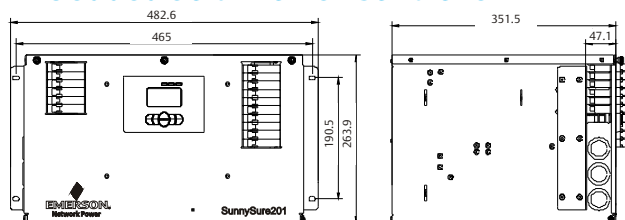

**Emerson Network Power Asia Pacific
(Headquarters)**

T: 852-25722201 F: 852-28029250

Australia

T: 1800-065345 F: 61-2-97438737

China

T: 86-755-86010808 F: 86-755-86010909

Hong Kong

T: 852-25722201 F: 852-28310114

India

T: 91-22-25807000 / 2388 F: 91-22-25828358

Indonesia

T: 62-21-2513003 F: 62-21-2510622

Japan

T: 81-3-54038594 F: 81-3-54032924

Korea

T: 82-2-34831502 F: 82-2-5927883

Malaysia

T: 603-7884 5000 F: 603-7884 5188

New Zealand

T: 64-3-3430235 F: 64-3-3430250

Philippines

T: 63-2-8934177 / 178 F: 63-2-8112027

Singapore

T: 65-64672211 F: 65-64670130

Taiwan

T: 886-2-2528 3535 F: 886-2-2528 3100

Thailand

T: 66-2-6178260 F: 66-2-6178277 / 278

Vietnam

T: 84-4-762 8908 F: 84-4-762 8909

Emerson Network Power.

The global leader in enabling business-critical continuity.

www.EmersonNetworkPower-Partner.com

■ AC Power Systems
■ Connectivity
■ DC Power Systems

■ Embedded Power
■ Rack Solutions
■ Outside Plant

■ Power Switching and Control
■ Precision Cooling
■ Site Monitoring

■ Surge Protection
■ Embedded Computing
■ Services

Business-Critical Continuity, Emerson Network Power and the Emerson Network Power logo are trademarks and service marks of Emerson Electric Co.
© 2009 Emerson Electric Co.