

Liebert XDP™

User Manual—50-60 Hz; 160kw Nominal Capacity



GENERAL SAFETY GUIDELINES



WARNING

Risk of electric shock. Can cause injury or death.

Disconnect local and remote power supplies before working within.

Before proceeding with installation of the XDP, read all instructions, verify that all the parts are included and check the nameplate to be sure the XDP voltage matches the available utility power.

Follow all applicable codes.



WARNING

Risk of unit falling over. Can cause death, injury or property damage. The XDP is top-heavy. Use extreme caution and care when moving and installing this unit.



NOTE

This document is intended to be used together with site specific documentation and documentation for other parts of the system (heat rejection devices and cooling modules).



NOTE

Before any action that could cause a disturbance in the XD system's cooling function is begun, the facility manager MUST be informed. In addition, after the action is taken and the work is finished, the facility manager MUST be informed.



CAUTION

Risk of piping and component rupture. May cause injury or equipment damage.

Do not close service valves without following recommended procedures for repair, maintenance and replacement of components. Closing service valves may isolate liquid refrigerant, causing high pressure and rupture of piping. Install pressure relief valves in field piping that may become isolated by service valves.

Figure i Model number nomenclature

Example: XDP160A--1

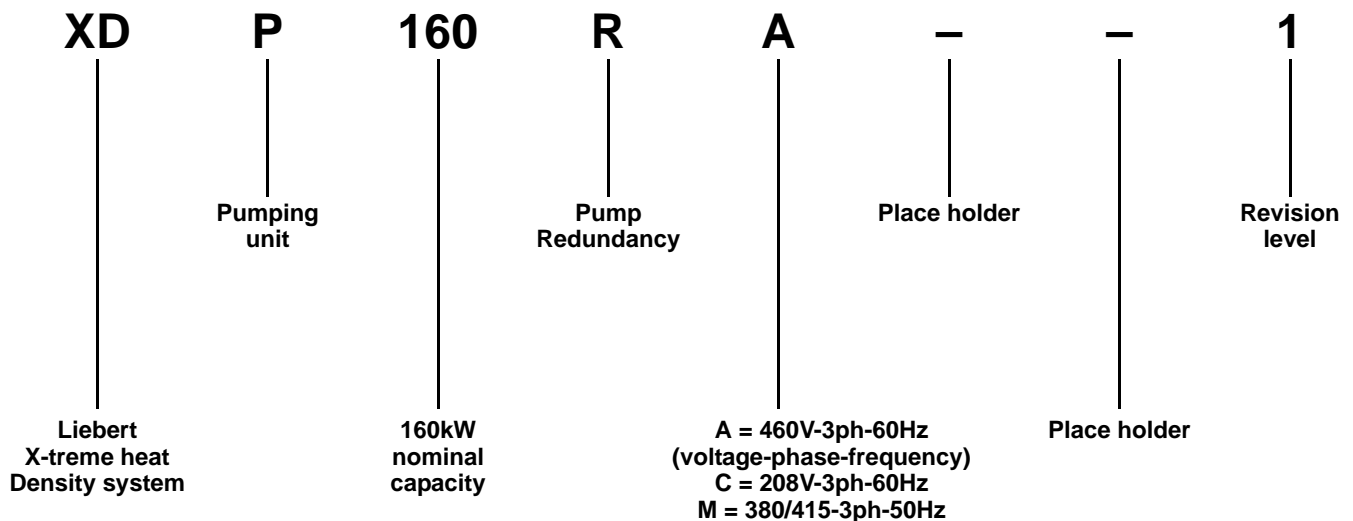

TABLE OF CONTENTS

GENERAL SAFETY GUIDELINES	INSIDE FRONT COVER
1.0 PRODUCT DESCRIPTION	1
1.1 General Product Information.....	1
1.1.1 Product/System Description.....	1
1.2 Equipment Inspection	1
1.3 Equipment Handling	2
1.3.1 Handling With Skid	2
1.3.2 Removal from Skid	2
1.3.3 Removing Piano Jacks	4
1.4 Mechanical Considerations	5
1.4.1 Positioning the XDP	5
1.5 Electrical Information	7
1.6 High Voltage Connections	7
1.6.1 Connecting High-Voltage Cables.....	7
1.7 Extra Low Voltage (ELV) Connections	9
2.0 PIPING	11
2.1 Connection Sizes.....	11
2.1.1 Recommended Pipe Size.....	11
2.2 XDP Interconnection with XD Cooling Modules.....	11
2.3 Piping Installation Method	12
2.3.1 Bypass Flow Controller	12
2.4 Piping Details—Shut-Off/Isolation Valves	13
2.4.1 Piping Installation Method	14
2.4.2 Piping Mains.....	14
2.4.3 Evacuation and Leak Check	14
2.5 Checklist for Proper Installation.....	14
3.0 CHECKLIST FOR XDP STARTUP	15
4.0 MICROPROCESSOR CONTROL	17
4.1 Feature Overview	17
4.1.1 Display	17
4.2 Controls.....	18
4.2.1 Feature Overview.....	18

4.3	Main Menu	18
4.3.1	Viewing or Changing Settings	18
4.3.2	SETPOINTS	19
4.3.3	STATUS	19
4.3.4	ACTIVE ALARMS	19
4.3.5	ALARM HISTORY	19
4.3.6	TIME	20
4.3.7	DATE	20
4.3.8	SETUP OPERATION	20
4.3.9	Password Security—SETPT PASSWORD and SERVICE PASSWORD	22
4.3.10	CALIBRATE SENSOR	23
4.3.11	ALARM ENABLE	23
4.3.12	ALARM TIME DELAY	23
4.3.13	COM ALARM ENABLE	23
4.3.14	CUSTOM ALARMS	24
4.3.15	CUSTOM TEXT	24
4.3.16	DIAGNOSTICS	24
5.0	ALARM DESCRIPTIONS AND SOLUTIONS	25
5.1	Alarm Descriptions	25
5.2	Red and Green Lamp Indicators	26
5.3	Alter Alarm Settings	26
5.3.1	Enable or Disable Alarms	26
5.3.2	Increase or Decrease Alarm Time Delays	27
5.4	System Shutdown Causes	27
6.0	TROUBLESHOOTING	28
7.0	MAINTENANCE	29
8.0	SPECIFICATIONS	30

FIGURES

Figure i	Model number nomenclature	Inside Front Cover
Figure 1	XDP components	1
Figure 2	Tie-down brackets and lag bolts to be removed.	2
Figure 3	Removing pallet boards for piano jack insertion.	3
Figure 4	XDP strapped to piano jack	3
Figure 5	Remove remaining lag bolts from one runner	3
Figure 6	Remove runner from pallet.	4
Figure 7	Sliding pallet from under XDP.	4
Figure 8	Dimensions	5
Figure 9	Piping access points	6
Figure 10	Front view of XDP and electrical enclosure.	7
Figure 11	Electrical enclosure knockout locations for field wiring.	8
Figure 12	High voltage connections—60Hz	8
Figure 13	High voltage connections—50Hz	9
Figure 14	Electrical enclosure knockout locations for Extra Low Voltage	9
Figure 15	XDP Extra Low Voltage field connections points	10
Figure 16	Piping arrangement for XDP/XDC used with XD cooling modules	12
Figure 17	Bypass flow controller arrangement	12
Figure 18	Bypass flow controller details, dimensions	13
Figure 19	General piping details	13
Figure 20	System R-134a liquid level	16
Figure 21	User interface	17

TABLES

Table 1	XDP dimensions	5
Table 2	Unit piping outlet connection sizes, inches, OD Cu	6
Table 3	Supply, return pipe sizes for refrigerant loop	11
Table 4	Bypass flow controllers.	12
Table 5	System refrigerant volume calculations – XDP with any model XDO/XDH/XDV/XD CoolFrame	16
Table 6	XDP pump light indicator—208V and 400V units	16
Table 7	User interface keypad functions.	17
Table 8	Setpoint functions, default values and allowable ranges	19
Table 9	Setup operation functions default values and allowable ranges.	20
Table 10	XDP DIP switches and factory settings.	21
Table 11	Liebert XDP specifications	30

1.0 PRODUCT DESCRIPTION

1.1 General Product Information

1.1.1 Product/System Description

Liebert's XDP refrigerant distribution unit is an interface between the building chilled water system and the cooling modules in the Liebert XD system. It is designed to circulate and control refrigerant to the cooling modules that are in the room with heat-producing equipment. The XDP consists of a cabinet that includes a heat exchanger, circulating pump(s), control valve, receiver, controls, valves and piping.

The XDP monitors room conditions and prevents coil condensation by maintaining the refrigerant being pumped to the cooling modules at a temperature above the room's dew point.

All functions, such as switching pumps (if applicable), controlling refrigerant temperature, etc., are automatic.

The XDP is rated for 160kW (546,000 BTU/H) of cooling.

Figure 1 XDP components

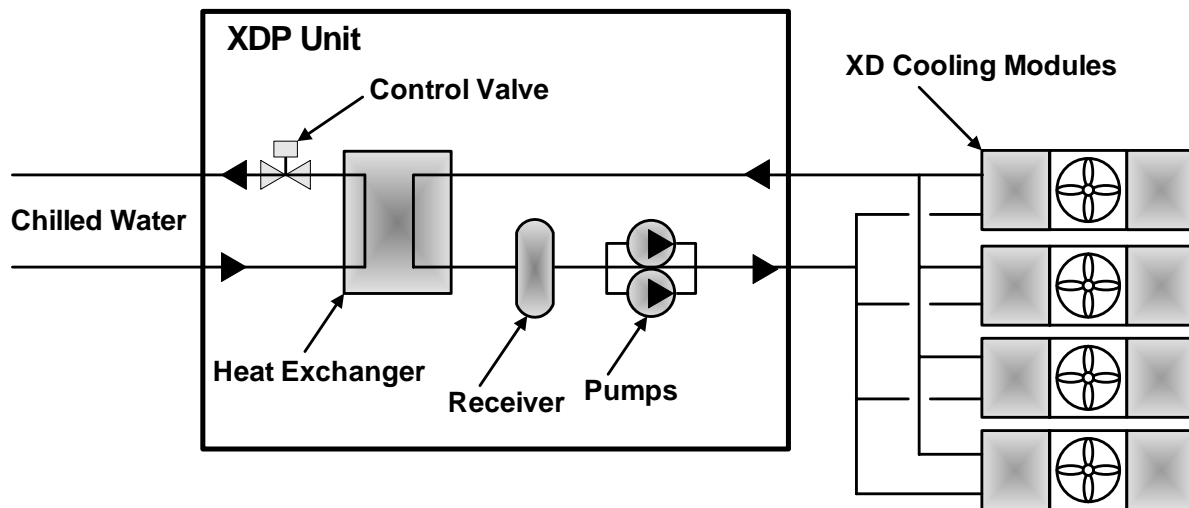

1.2 Equipment Inspection

When the unit is delivered, inspect all items for visible and concealed damage. Damage should be immediately reported to the carrier and a damage claim filed with a copy sent to Liebert or to your sales representative.

1.3 Equipment Handling



WARNING

Risk of unit falling over. Can cause injury or death.

The XDP is top-heavy. Use extreme caution and care when moving and installing this unit.



NOTE

Personnel should be properly trained and certified to move and rig equipment.

1.3.1 Handling With Skid

- Always keep the unit upright, indoors and protected from damage.
- If possible, transport the unit using a forklift truck. Otherwise use a crane with belts or cables. In either case, do NOT press on the top edges of the packaging.
- If using a forklift, make sure the forks (if adjustable) are spread to the widest allowable distance to still fit under the skid.
- When moving the skidded unit with a forklift truck, do not lift the unit any higher than 6" (152mm) off the ground. If circumstances require the unit to be lifted higher than 6" (152mm), great care must be exercised and all by-standing personnel are to be no closer than 20 feet (6m) from the lift point of the unit.



CAUTION

Risk of structural interference. Can cause equipment or building damage.

While on the skid, the unit is too tall (83" [2108mm] overall height) to fit through a standard doorway. Any attempt to move the unit, while skidded, through a standard doorway will cause damage to the unit and to the building.

1.3.2 Removal from Skid

Liebert recommends using dual hand trucks or a similar method to remove the XDP from the skid. This is to ensure that both ends of the unit are firmly secure and to provide a good means of unit mobility.

1. Always keep the unit upright, indoors and protected from possible damage.
2. Remove the exterior packaging. Leave the plastic bag over the XDP until the unit has been moved to its final location. The bag will protect the painted panels against scuffing.
3. Remove two (2) corner tie-down brackets from one side of the unit, on a non-runner notch side of the pallet. Remove eight (8) lag bolts from two (2) end deck boards on the same end where the tie-down brackets were removed (refer to **Figure 2**).

Figure 2 Tie-down brackets and lag bolts to be removed

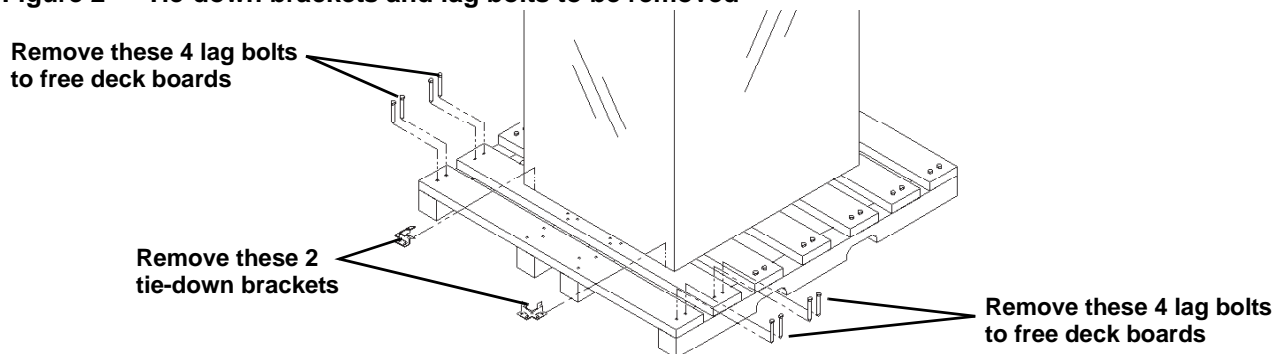

- Remove the two (2) end deck boards from one end of the pallet and the attached, notched section of the center runners (refer to **Figure 3**).

Figure 3 Removing pallet boards for piano jack insertion

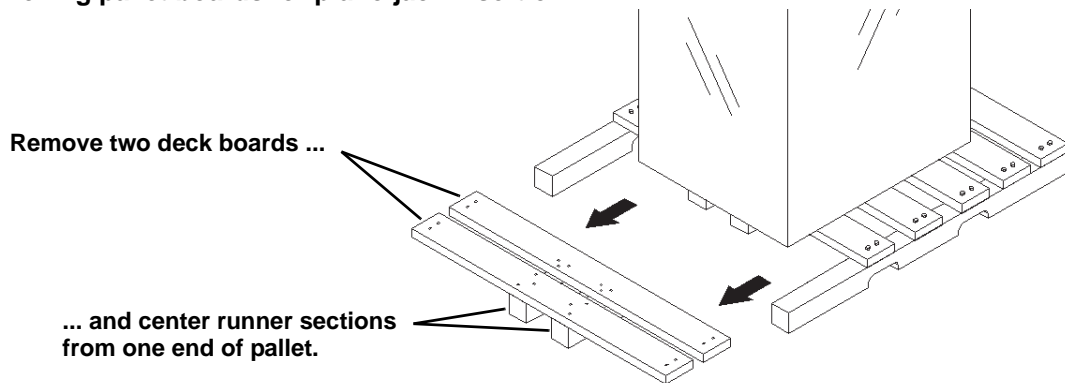

- Place a piano jack with its forks snugly against the bottom of the unit and strap the XDP securely to the jack (refer to **Figure 4**).



NOTE

Place a mover's blanket or other cushioning material between the piano jack and the unit's side panels.

Figure 4 XDP strapped to piano jack

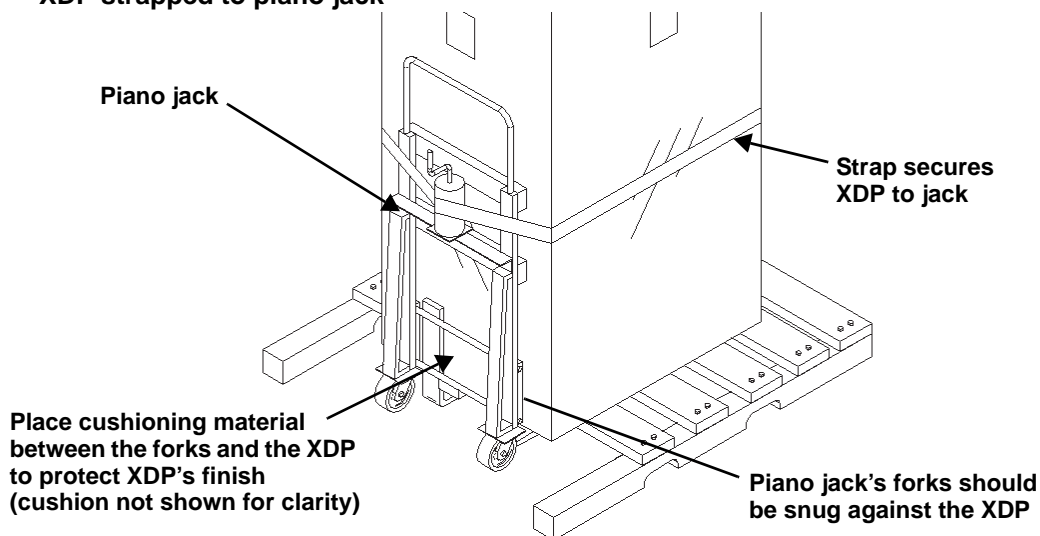

- Repeat **Steps 2, 4 and 5** for the opposite side of the unit. When these steps have been completed, the XDP will be supported by two piano jacks, one on either side.
- Remove all of the remaining lag bolts from one (1) of the pallet's outside runners (see **Figure 5**).

Figure 5 Remove remaining lag bolts from one runner

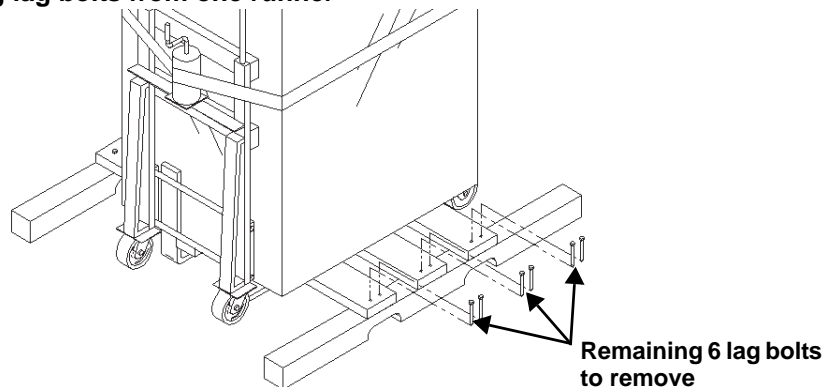

8. Remove the runner from which all lag bolts have been removed (refer to **Figure 6**).

Figure 6 Remove runner from pallet

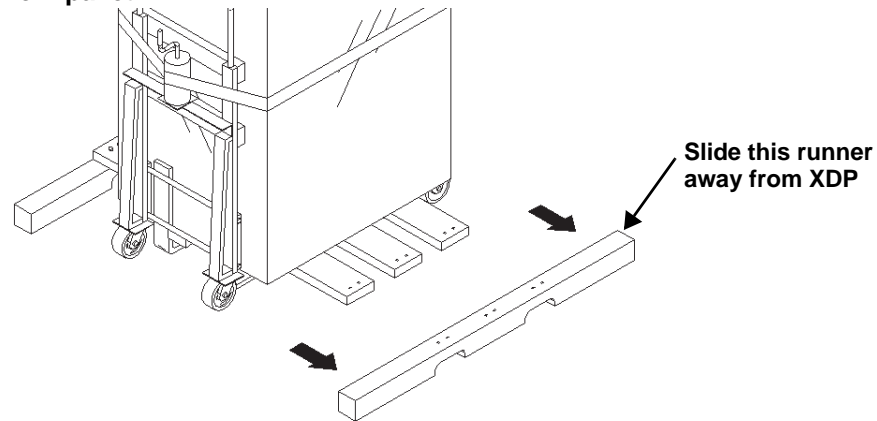

9. Using the pallet jacks, raise the secured unit to the highest point that the piano jacks will allow. Once the unit has been raised, slide the remainder of the pallet from under the XDP (see **Figure 7**). Lower the XDP so that its base is approximately 1" (25.4mm) off the ground.

Figure 7 Sliding pallet from under XDP

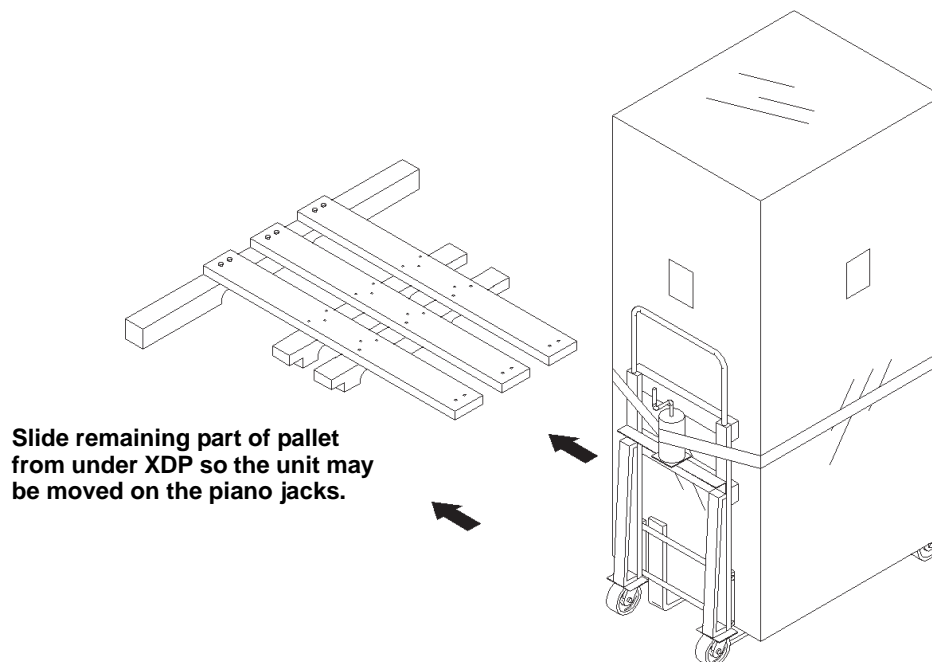

1.3.3 Removing Piano Jacks

Once the unit has been moved to the installation location, Liebert recommends the following method to remove the piano jacks:

1. Lower the unit as far as the piano jacks will allow.
2. Undo all strapping holding the piano jacks to the unit.
3. Remove all cushioning material used to protect the unit from the straps and the piano jacks.
4. Use a pry bar or other lever to lift one side of the XDP enough to allow removal of the piano jack.
5. Repeat **Step 4** to remove the piano jack on the opposite side.
6. Remove the plastic bag.

1.4 Mechanical Considerations

1.4.1 Positioning the XDP

Install the XDP according to the site specific documentation and secure the unit to the floor.

The XDP can be installed near a wall or another XDP. However, there must be at least 3 feet (92cm) clearance in front of the XDP as service access for components in the unit.

For additional technical information, refer to the System Design and Configuration Document for the Liebert XD™ System, SL-16655. The document is available in electronic format at Liebert's Web site, www.liebert.com, as well as from your local Liebert representative.

Figure 8 Dimensions

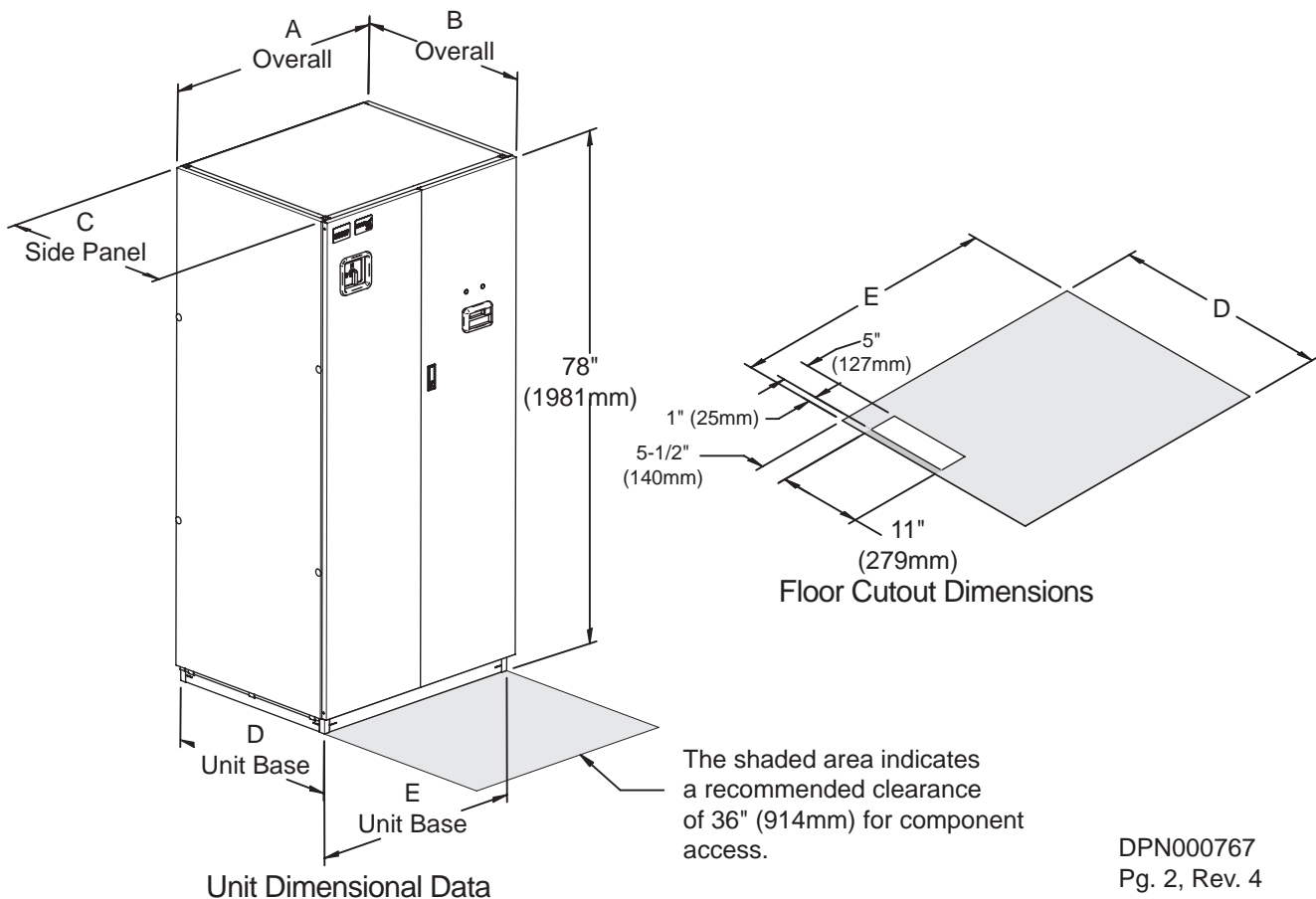
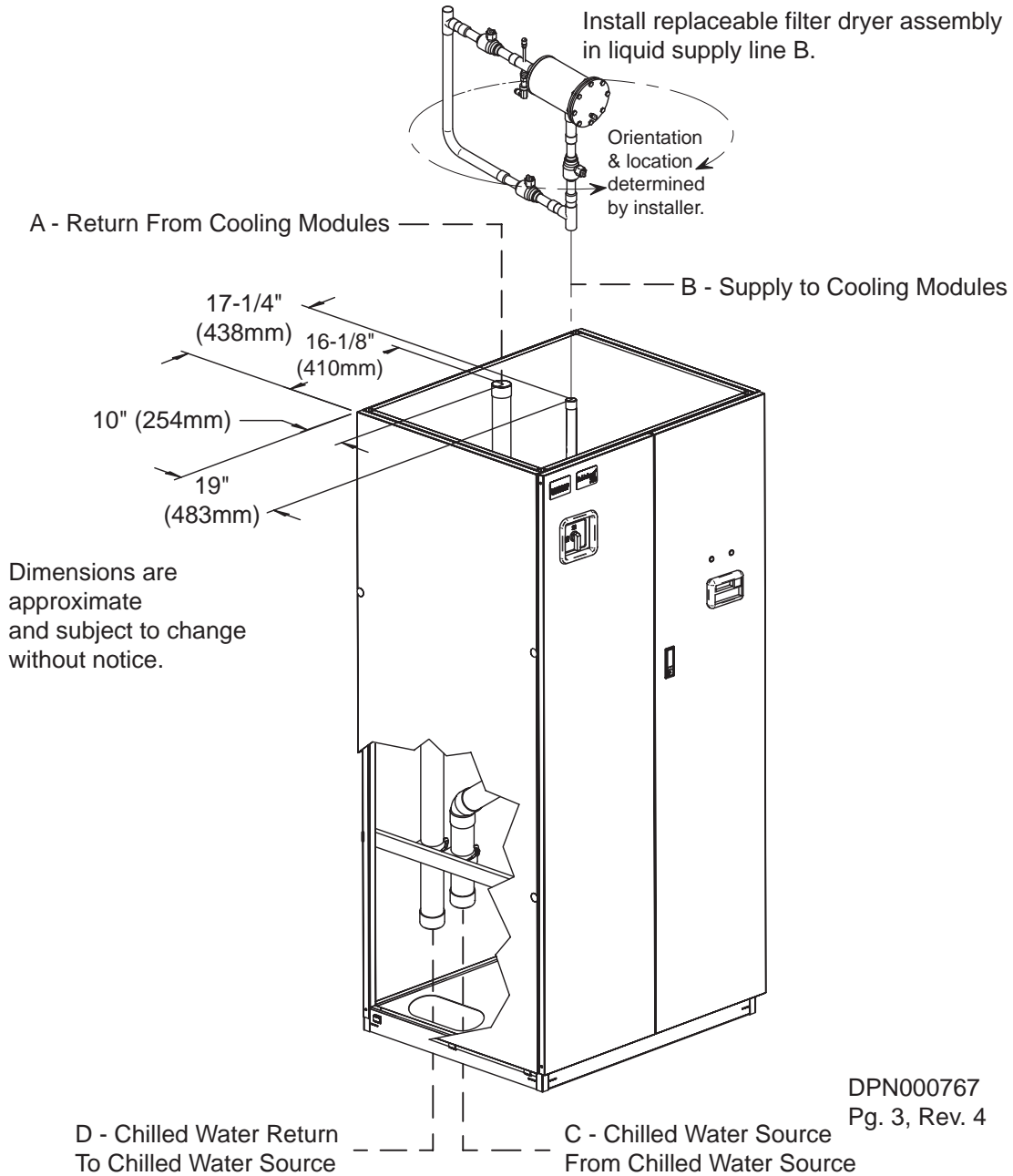

Table 1 XDP dimensions

Model 50/60Hz	Dimensional Data inches (mm)					Shipping Weight, lb (kg)	
	A	B	C	D	E	Domestic	Export
XDP160	38 (965)	34 (864)	33-1/8 (841)	33 (838)	36 (914)	990 (449)	1067 (484)

Figure 9 Piping access points



DPN000767
Pg. 3, Rev. 4

Table 2 Unit piping outlet connection sizes, inches, OD Cu

Model	Pipe Connection Point			
	A	B	C	D
50/60 HZ				
XDP160	2-1/8	1-1/8	2-5/8	2-5/8

1.5 Electrical Information

1.6 High Voltage Connections

Make sure the actual supply voltage and frequency correspond to the voltage and frequency indicated on the XDP's rating plate. The unit must be installed in accordance with national wiring regulations.

Connect cables for high voltage supply to the electrical box in the XDP according to **Figure 12** and make sure that the phases are correctly connected.



WARNING

Risk of electric shock. Can cause injury or death.

Disconnect all local and remote electric power before working within the unit.



CAUTION

Risk of sharp edges and heavy parts. Can cause injury or equipment damage.

Wear gloves to prevent injury to hands.

Damage to wiring or components may make unit unsafe to operate.

Use caution when installing wiring to prevent damage to factory wiring.

Install protective bushings in wiring knockouts as required.

Do not disturb factory wiring or route field-installed wiring over electrical terminals.

Use NEC Class 1 wiring for all hazardous voltage electrical power supplies.

Check and retighten all wiring connections before starting.

1.6.1 Connecting High-Voltage Cables

1. Turn the XDP's disconnect switch to the Off position (see **Figure 10**). Open the front doors and push down on the enclosure cover latch to open the hazardous voltage enclosure cover.

Figure 10 Front view of XDP and electrical enclosure

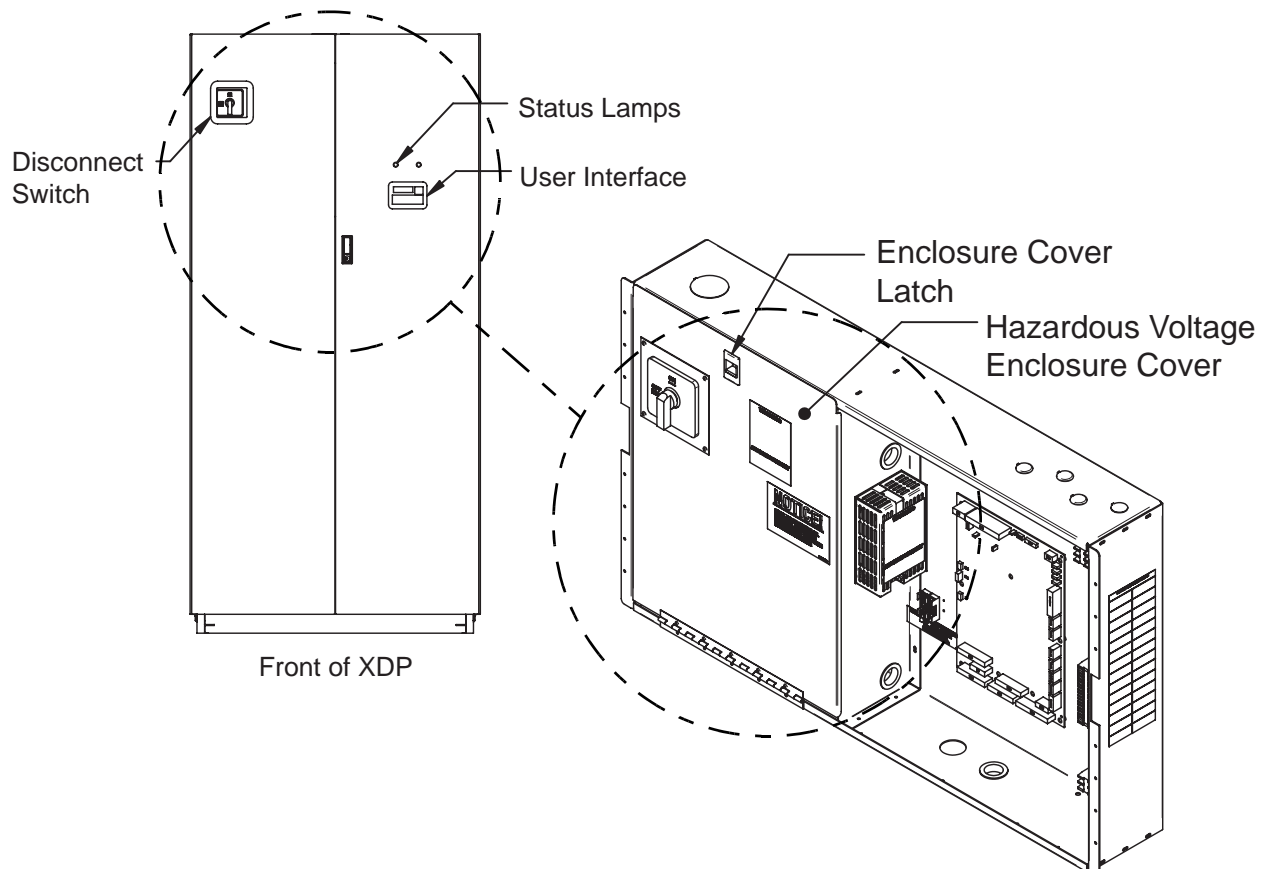

- Determine which knockouts in the electrical enclosure will be used and remove them (see **Figure 11**).

Figure 11 Electrical enclosure knockout locations for field wiring

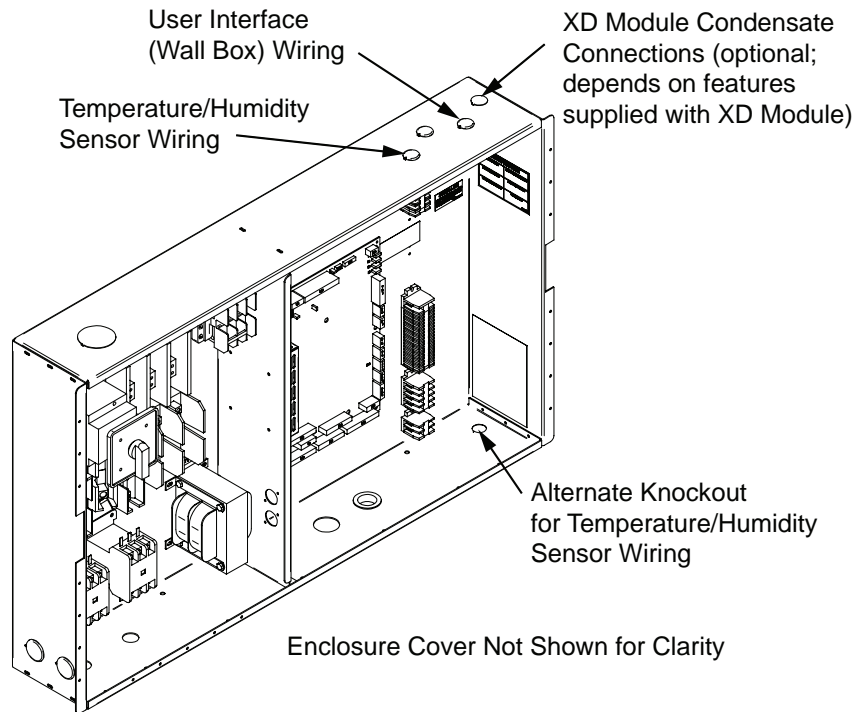

- Route the input hazardous voltage electrical power wiring through the top left knockout (see **Figure 11**) to the disconnect switch L1, L2 and L3 (see **Figures 12 and 13**). Observe proper phasing.
- Connect the ground wire to the ground lug (see **Figures 12 and 13**), which is in the middle left of the enclosure.

Figure 12 High voltage connections—60Hz

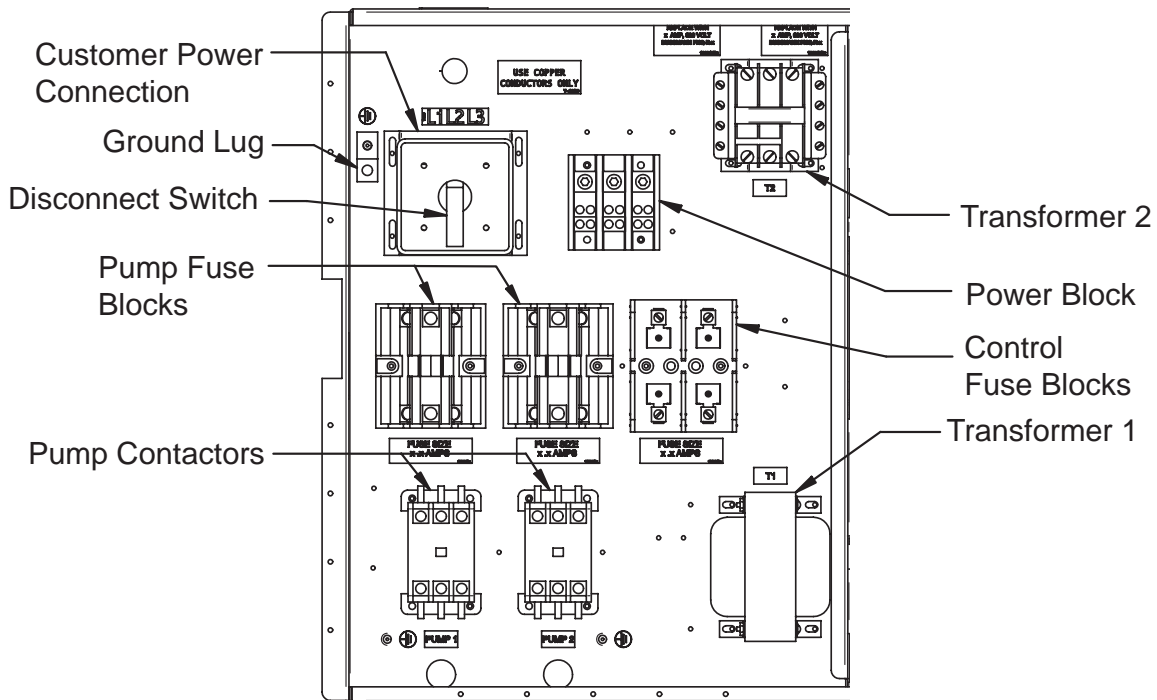
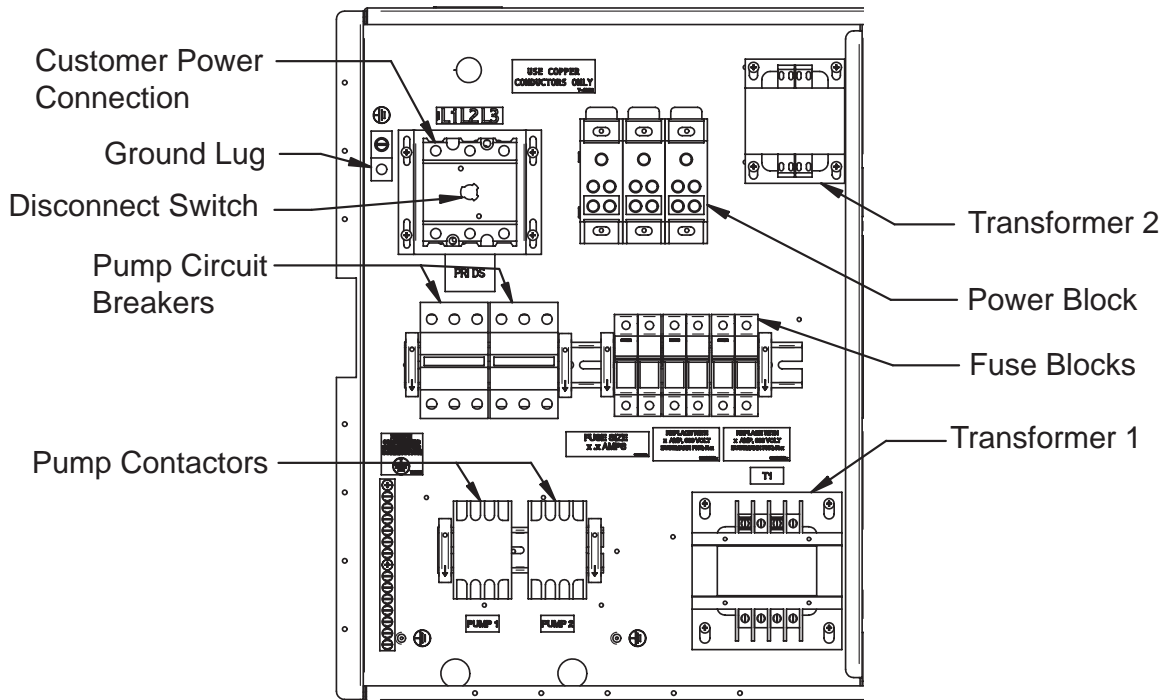

Figure 13 High voltage connections—50Hz



1.7 Extra Low Voltage (ELV) Connections

Extra Low Voltage power output is 30V and 100VA or less.

1. Turn off all unit power before connecting cables or wires. Failure to do so may damage this equipment (refer to **Figure 14**).
2. Route low voltage electrical connections through the appropriate knockouts as indicated below.
3. User interface requires four thermostat-type wires (jacketed) connected to the control board (see **Figure 15**).

Figure 14 Electrical enclosure knockout locations for Extra Low Voltage

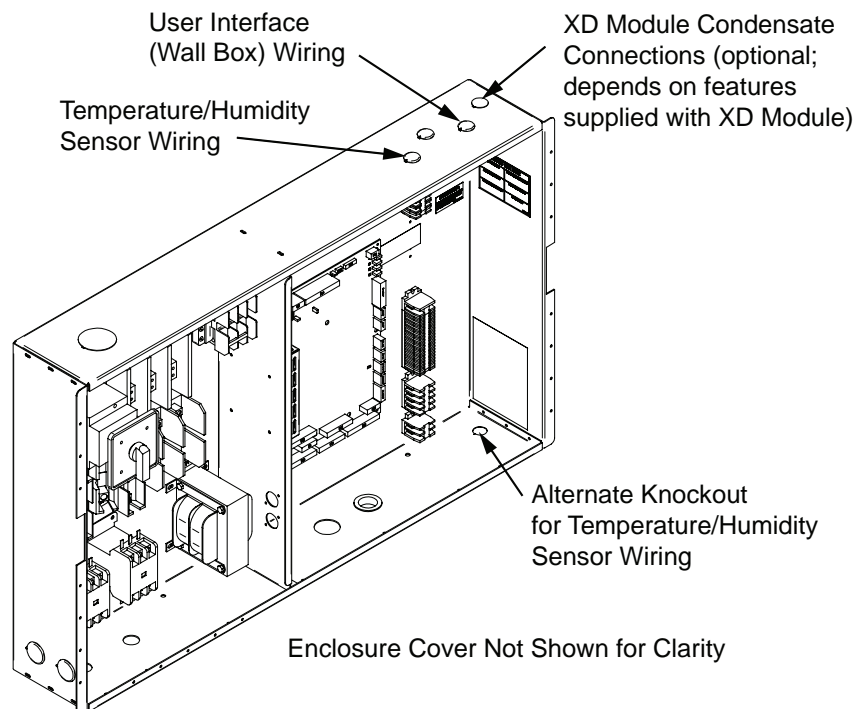

Field Connections—All Units

- Connect the control display panel cable to terminal block TB3 terminals 1 through 4 on the XDP control board as shown (refer to **Figure 15**). The display panel may be mounted in the XDP front right door if the XDP is located in the area that it conditions. The display panel must always be installed in the conditioned space.
- Connect the provided remote temperature / humidity sensor extension cable to the factory-installed cable connected to P16 on the control board. Install this sensor in the higher-temperature portion of the cold aisle in the space conditioned by the XD cooling module connected to the XDP.
- Place the sensor on the RETURN AIR side of the primary air mover (e.g., Liebert Deluxe System 3) or directly in the cold aisle. Do not install the sensor where ambient air may cause false readings, for example, near unsealed doors, windows and similar areas.

Field Connections—Optional for All Units

- Connect field wiring from the optional XD cooling module condensation detection circuit to terminal strip locations H2O (24) and H2O (51).
- Connect optional field wiring from remote devices to remote alarm device, common alarm output, site monitor and remote shutdown, if applicable. See terminal strip descriptions in **Figure 15**.

Figure 15 XDP Extra Low Voltage field connections points

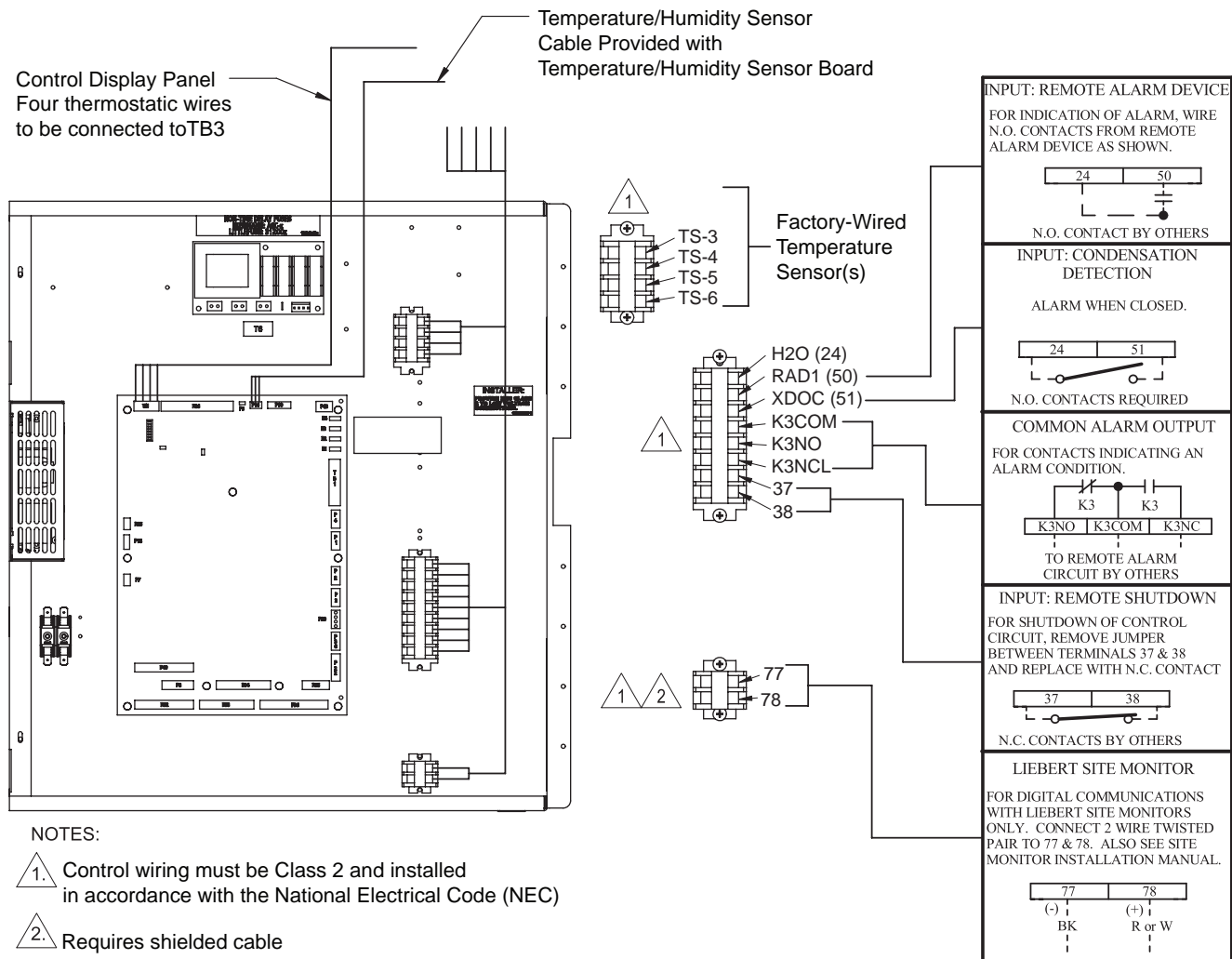

2.0 PIPING

2.1 Connection Sizes

The copper pipe connections on the XDP are:

Building Chilled Water Supply	2-5/8" OD
Building Chilled Water Return	2-5/8" OD
Refrigerant Supply	1-1/8" OD
Refrigerant Return	2-1/8" OD

2.1.1 Recommended Pipe Size

Connect the main pipes between the XDP and the XD cooling modules according to site specific documentation and the configuration guide for the Liebert XD system.

Elbows and restrictions must be minimized to get good fluid flow.

Table 3 Supply, return pipe sizes for refrigerant loop

Pipe Function	Size / Equivalent Pipe Length
XDP supply line, from XDP supply to farthest XD cooling module	1-1/8" OD for lengths up to 60 feet
	1-3/8" OD for lengths over 60 but less than 175 feet
XDP return line, from farthest XD cooling module to XDP return	2-1/8" OD for lengths up to 60 feet
	2-5/8" OD for lengths over 60 but less than 175 feet
From any model XDO/XDH supply to supply line of XDP	1/2" OD for lengths up to 10 feet
	7/8" OD for lengths over 10 but less than 25 feet
From any model XDO/XDH return to return line of XDP	7/8" OD for lengths up to 10 feet
	1-1/8" OD for lengths over 10 but less than 25 feet
From any model XDV/XD CoolFrame supply to supply line of XDP	1/2" OD for lengths up to 10 feet
	5/8" OD for lengths over 10 but less than 35 feet
From any model XDV/XD CoolFrame return to return line of XDP	5/8" OD for lengths up to 10 feet
	7/8" OD for lengths over 10 but less than 35 feet

2.2 XDP Interconnection with XD Cooling Modules

All piping must be ASTM (American Society for Testing and Materials) Type L copper pipe.

The XDP may be connected to XD cooling modules with either Liebert's XD prefabricated piping assembly or with rigid, off-the-shelf piping. In either setup, piping for the XD system is arranged in a manner similar to piping for a chilled water system. XD cooling modules are connected in parallel between main return and supply pipes going to and from the XDP/XDC. For piping details, refer to Liebert's XD System Design Manual, SL-16655. **The guidelines provided for pipe size must be strictly followed. Failure to size the main lines and connection lines adequately may result in reduced cooling capacity.** The critical aspects of pipe sizing are related to refrigerant volume and pressure drop. Both must be minimized.

Figure 16 Piping arrangement for XDP/XDC used with XD cooling modules

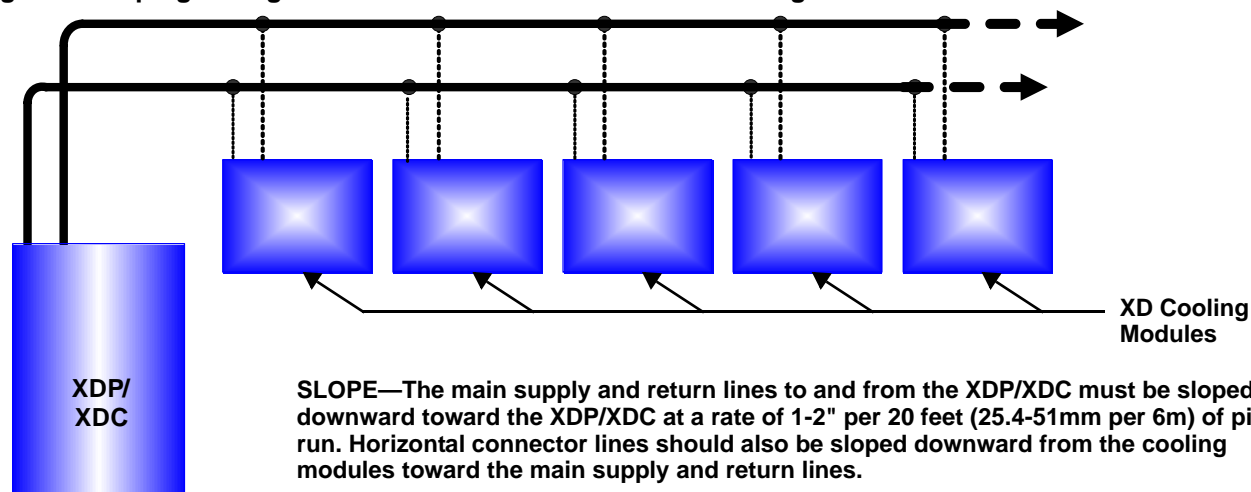

2.3 Piping Installation Method

The assembly and connection means used for piping in the XD system are similar to that of conventional refrigeration systems. All piping should be installed with high-temperature brazed joints. Brazing material may be used, but soft soldering is not recommended. If brazing material is used, the lines being brazed **MUST** be filled with flowing dry nitrogen during brazing to prevent excessive oxidation and scale formation inside the piping. Prevailing good refrigeration practices should be employed for piping supports, leak testing, dehydration and charging.

2.3.1 Bypass Flow Controller

One or more bypass flow controllers are required, depending on the number of cooling modules used. Calculate the combined model size of all cooling module in your system. Find this total model size in **Table 4** to determine the required number of bypass flow controllers. For example, if six XDV8 and one XDH-32 modules are used, the combined model size is 80; two flow controllers are required.

Table 4 Bypass flow controllers

Cooling Modules - Total Model Size	Required Number of Bypass Flow Controllers
32 to 63	3
64 to 95	2
96 to 127	1
128 to 160	0

Figure 17 Bypass flow controller arrangement

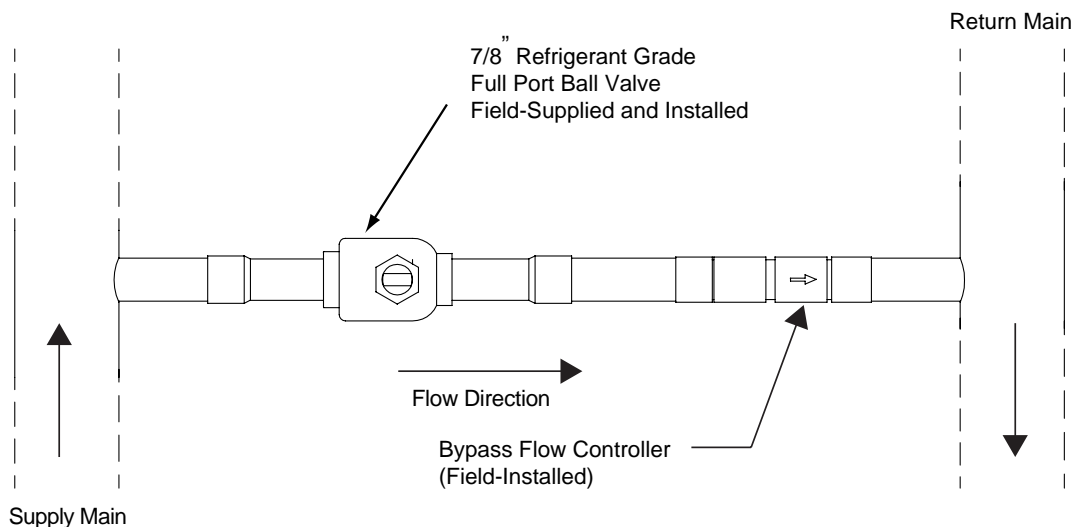
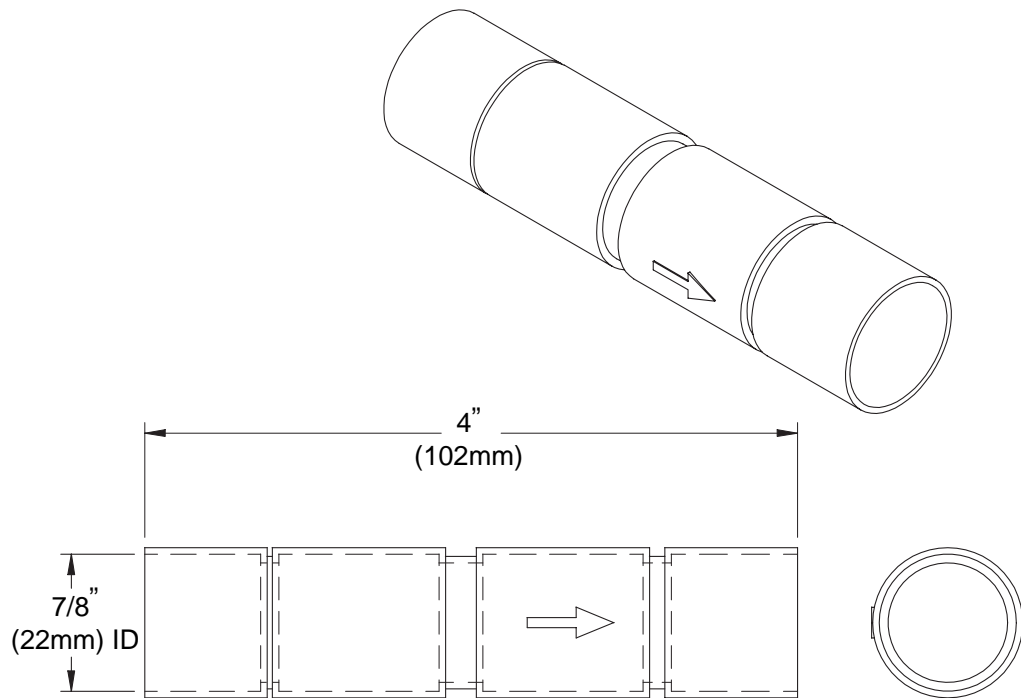

Figure 18 Bypass flow controller details, dimensions



2.4 Piping Details—Shut-Off/Isolation Valves

To allow for maintenance of the XDP, isolation valves must be installed on the chilled water circuit (see Figure 19).

Figure 19 General piping details

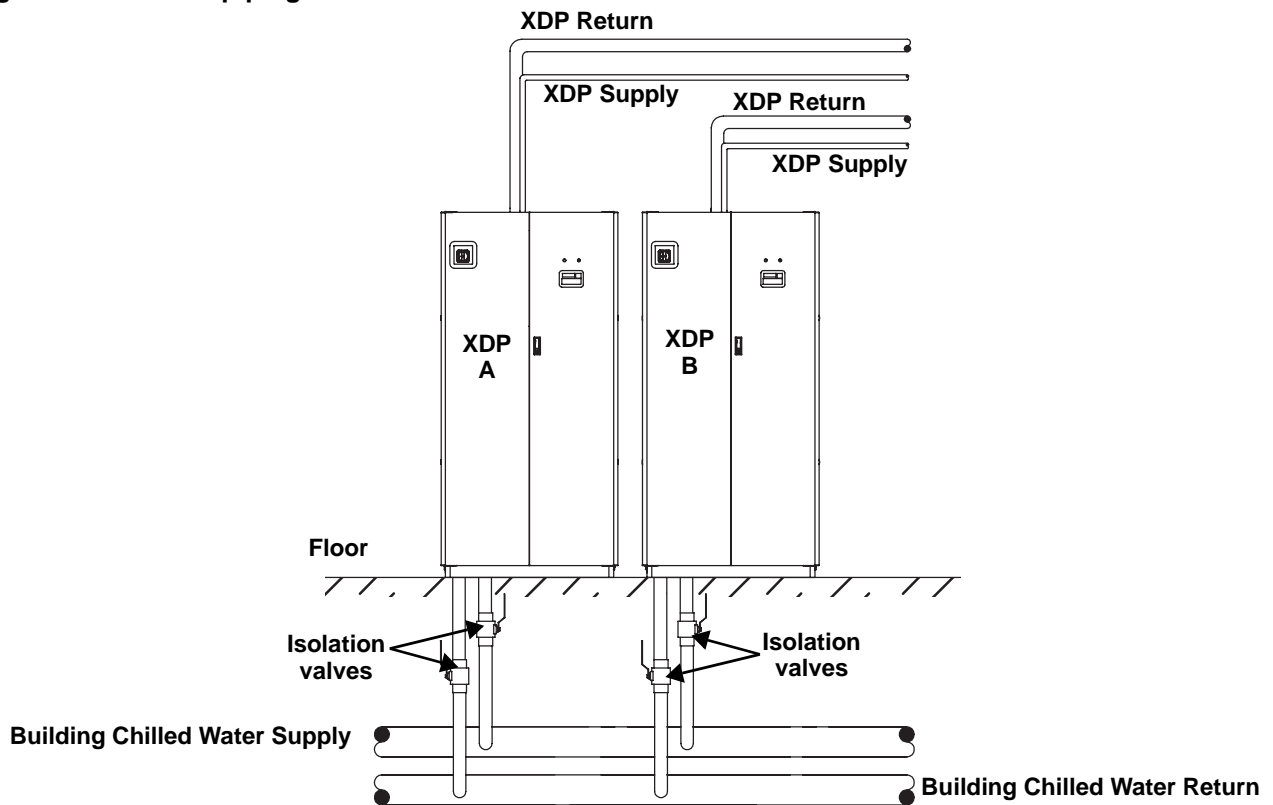

2.4.1 Piping Installation Method

All piping should be installed with high temperature brazed joints. Prevailing good refrigeration practices should be employed for piping supports, leak testing, dehydration and charging. Liebert highly recommends venting the pressure relief of the XDP (located at the top of the receiver) outside of the conditioned space where it is open to the atmosphere.

2.4.2 Piping Mains

All refrigeration piping mains, both supply and return, should be installed with a downward pitch toward the XDP of 1-2" for every 20 feet (25.4-51mm per 6m) of pipe run.

Install a 20-40 mesh strainer on the chilled water supply to the XDP. The strainer is needed to prevent particles in the chilled water from entering the heat exchanger of the XDP.

2.4.3 Evacuation and Leak Check

1. Open all service valves, including those located outside of the XDC.
2. Place 150 psig (1034kPa; 10.34 bars) of dry nitrogen with a tracer of R-134a in the system.



CAUTION

Risk of overpressurization. Can cause equipment damage.

Do not exceed 150 psig (1034 kPa; 10.34 bars) in the R-134a circuit.

3. Check the system for leaks with a suitable leak finder
4. After completion of the leak testing, release the test pressure (per local code) and connect to vacuum pump(s) at the Schrader valves.
5. After four hours of pulling a deep vacuum, check the vacuum level and if it has not changed, break the vacuum with dry nitrogen.
6. Pull a second vacuum to 250 microns or less. Recheck the vacuum level after 2 hours.

2.5 Checklist for Proper Installation

- 1. Unpack and check received material.
- 2. Position the XDP and secure it to the floor.
- 3. Wire high voltage connections.
- 4. Wire low voltage connections.
- 5. Connect the building chilled water piping to the XDP.
- 6. Connect the XD cooling module piping to the XDP.
- 7. Check the system for leaks.
- 8. Hold a vacuum on the system.
- 9. Charge the system with refrigerant.
- 10. Make sure that all piping has proper insulation.

3.0 CHECKLIST FOR XDP STARTUP



WARNING

Risk of piping and component rupture. May cause injury or equipment damage. Closing service valves may isolate liquid refrigerant, causing high pressure and rupture of piping. Do not close valves without following recommended procedures for repair, maintenance and replacement of components. Install pressure relief valves in field piping that may become isolated by service valves.



NOTE

Before any action that could cause a disturbance in the XD system's cooling function is begun, the facility manager MUST be informed. In addition, after the action is taken and the work is finished, the facility manager MUST be informed

1. Verify that bypass flow controllers were installed (if applicable), see **Table 4**.
2. Check all isolation ball valves in the XDP and XD cooling module and verify that all are open.
3. Check rotation of the XDP's pumps.
 - On 460V units only**, use the rotation device provided—this device must be held against the pump housing—at the inspection screw prior to energizing the pumps—counterclockwise indicates proper rotation; clockwise indicates incorrect rotation.
 - On 208V units only**, view the LED indicator on the pump—Green indicates proper rotation; Green and Red indicate incorrect rotation.
4. Check rotation of fans on XD cooling module units.
5. Verify that air is being discharged into the cold aisle.
6. Confirm that the total calculated refrigerant R-134a amount has been properly charged into the system (see **Table 5**).
7. Confirm that the remote temperature/humidity sensor provided has been installed in the correct location.

The correct location is near the return side of a main air mover, such as a Liebert Deluxe System 3. If more than one XDP is installed, use a different location for each remote sensor for best temperature/humidity calculation.

The XDP system is now ready to be turned ON.

1. Turn On all of the XD cooling module fans.
2. Turn the XDP On via its user interface (I/O button). Allow the system to attempt to start for at least 2 minutes.
 - If the XDP pump cannot maintain flow and continues to switch over due to starting difficulties, proceed to **Step 4** and refer to **6.0 - Troubleshooting**.
3. If constant flow is established, wait until the XDP has been operating for 10-15 minutes, then verify that the refrigerant level in the receiver sight glass is between the second and third level (see **Figure 20**). Add or remove charge, if necessary.
4. Check pressure differential functionality:

The XDP system should be On. If it is Off:

- a. Turn On the XD cooling module fans
- b. Turn the XDP On via user interface (I/O button).

If there is no “Loss of Flow” alarm present—This suggests that there is flow. Test the pressure differential by closing the ball valve on either the suction line or discharge line to stop the flow.

This should prompt an alarm for “loss of flow on P1.” This alarm confirms that the switch has opened on low pressure (below 6 psi; 41kPa; 0.41 bars).

If there is a “Loss of Flow” alarm present—This suggests that there is no flow. Verify that this is correctly annunciated by looking at the sight glass in the receiver. If a true no-flow condition exists, the level will not move.

However, **if there is flow, but the differential reading is faulty**, the level will slowly drop, indicating flow, while the loss of flow alarm is annunciated.

Check the pressure differential physically by making sure that the electrical connections are properly connected. Then check the pressure differential electrically by making sure that the unit has 24VAC across it.

Figure 20 System R-134a liquid level

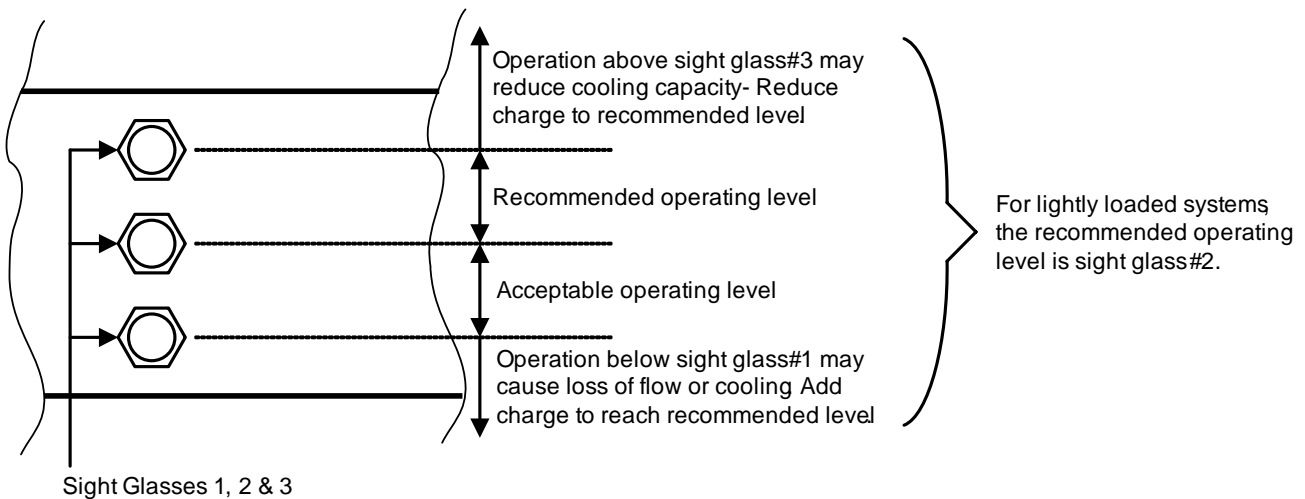

NOTE

All lengths in **Table 5** are actual pipe lengths, not equivalent pipe lengths.



NOTE

System refrigerant volume calculations in **Table 5** are based on a fully loaded system. Additional charge may be required for lightly loaded systems.

Table 5 System refrigerant volume calculations – XDP with any model XDO/XDH/XDV/XD CoolFrame

157 lb. (65.7kg) R-134a per XDP (includes charge of one XDP while running)
+3.55 lb. (0.66kg) R-134a per XDO (does not include piping connector lines to and from XDO)
+2.32 lb. (1.05kg) R-134a per XDV (does not include piping connector lines to and from XDV)
5.32 lb. (2.41kg) R-134a per XDH (does not include piping connector lines to and from XDH)
1.41 lb. (0.64kg) R-134a per XD CoolFrame (does not include piping connector lines to and from XD CoolFrame)
0.45 lb. per foot (0.2kg per 305mm) of main supply actual length per 1-1/8" OD copper tubing
0.68 lb. per foot (0.3kg per 305mm) of main supply actual length per 1-3/8" OD copper tubing
0.28 lb. per foot (0.12kg per 305mm) of main return actual length per 2-1/8" OD copper tubing
0.43 lb. per foot (0.195 kg per 305mm) of main return actual length per 2-5/8" OD copper tubing
0.08 lb. per foot (0.04kg per 305mm) of 1/2" OD XDO/XDH/XDV/XD CoolFrame supply connector actual length
0.13 lb. per foot (0.06kg per 305mm) of 5/8" OD copper tubing XDV/XD CoolFrame supply connector actual length
0.26 lb. per foot (0.12kg per 305mm) of 7/8" OD XDO/XDH supply connector actual length
0.02 lb. per foot (0.01kg per 305mm) of 5/8" OD copper tubing XDV/XD CoolFrame return connector actual length
0.04 lb. per foot (0.02kg per 305mm) of 7/8" OD copper tubing XDV/XD CoolFrame return connector actual length
0.04 lb. per foot (0.02kg per 305mm) of 7/8" OD copper tubing XDO/XDH return connector actual length
0.07 lb. per foot (0.03kg per 305mm) of 1-1/8" OD copper tubing XDO/XDH return connector actual length
= Amount of refrigerant needed for ONE system combining an XDP with XDO, XDH, XDV and XD CoolFrame

Table 6 XDP pump light indicator—208V and 400V units

Indicator Lights		Description
Green	Red	
Off	Off	The electricity supply has been switched off or the pump has been cut out by the thermal switch.
On	Off	The electricity supply has been switched on. Normal operation.
On	On	The electricity supply has been switched on. The direction of rotation is wrong .

4.0 MICROPROCESSOR CONTROL

4.1 Feature Overview

The microprocessor control for the Liebert XDP unit features an easy-to-use menu-driven LCD. The menu, control features and circuit board details are described in this section.

Figure 21 User interface



Active alarms are displayed on the LCD screen and sound an audible beep. To silence an alarm, press the Alarm Silence/Help key as prompted on the display.

Setpoints, DIP switch settings and other selections were made during factory testing of the unit based on typical operating conditions. (Other default selections were made according to options included with the unit.)

ADJUST THE FACTORY DEFAULTS ONLY IF THEY DO NOT MEET YOUR SPECIFICATIONS.

Allowable ranges are displayed by pressing the Help key. A password will be required (if enabled) to change setpoints, time delays, etc.

The display normally shows the leaving refrigerant temperature on the first line and alternates between the dew point and the number of alarms present on the second line.

4.1.1 Display

To turn the unit On, press the On/Off (I/O) key after power is applied to the XDP.

To turn the unit Off, press the On/Off (I/O) key before power is disconnected.

Table 7 User interface keypad functions

Keypad	Function
On/Off (I/O)	Turns the unit On or Off (top far left keypad)
Menu	Enables the user to access the program menu to change setpoints, alarms, etc. (top near left)
Up Arrow Key	Raises the value of displayed parameter while in a set mode (set points, time, etc).(arrow, top near right)
Escape (Esc)	Allows user to move back to a previous menu (top far right)
Alarm Silence	If an alarm is present, press this key to silence the alarm. Help text will appear if this key is pressed when no alarm is present (bottom left)
Down Arrow Key	Lowens the value of displayed parameter while in a set mode (set points, time, etc).(arrow, bottom near right).
Enter	After setting a control value, press ENTER to store the information in the microprocessor (bottom right).

4.2 Controls

The Microprocessor Control for the Liebert XDP features an easy-to-use, menu-driven liquid crystal display. The menus, control features and circuit board details are described in this section.

4.2.1 Feature Overview

The XDP maintains the refrigerant being pumped to XD cooling modules at a temperature above the room dew point, preventing condensation.

4.3 Main Menu

Press the MENU key to display the Main Menu. The menu selections are:

- SETPOINTS
- STATUS
- ACTIVE ALARMS
- ALARM HISTORY
- TIME
- DATE
- SETUP OPERATION
- SETPT PASSWORD
- SERVICE PASSWORD
- CALIBRATE SENSOR
- ALARM ENABLE
- ALARM TIME DELAY
- COM ALARM ENABLE
- CUSTOM ALARMS
- CUSTOM TEXT
- DIAGNOSTICS
- END OF MENU

4.3.1 Viewing or Changing Settings

To access a menu option:

1. Use the Up or Down arrow keys to scroll to the menu option.
2. Press the ENTER button to view the current setting.
3. To change the setting, use the Up or Down arrow keys.
4. Press ENTER to save the change.

4.3.2 SETPOINTS

Selecting SETPOINTS from the Main Menu will reveal the following menu items:

Table 8 Setpoint functions, default values and allowable ranges

Menu Item	Function	Default, °F (°C)	Range, °F (°C)
MIN TEMP SP	Minimum room temperature setpoint	72 (22)	50-80 (10-27)
HI CW TEMP	High chilled water temperature setpoint	55 (13)	35 to 95 (2-35)
HI AIR TEMP	High room air temperature setpoint	80 (27)	35 to 95 (2-35)
LO AIR TEMP	Low room air temperature setpoint	65 (18)	35 to 95 (2-35)

* For optimal cooling performance, the minimum temperature setpoint should be at least 1-2° below the expected temperature at the remote sensor, which may require additional consideration of the remote sensor location or minimum temperature setting. If the minimum temperature setpoint is set above the typical remote temperature sensor reading, this will reduce the XD cooling output and, in extreme cases, cause erratic XD performance.

MIN TEMP SP

Minimum Room Temperature Setpoint—This is used to keep the room temperature above the setpoint. The XDP can lower the room temperature too much depending on the room dew point and load. This setpoint will back off the cooling to keep the room temperature above this temperature.



NOTE

This is not a true room temperature setpoint. The XDP has no heaters, it will try to cool as much as possible. If it is able to cool the room to this setpoint, it will back off its cooling capability to try to keep the room temperature at or above this setpoint.

HIGH CW TEMP

High Chilled Water Temperature Setpoint—There could be many reasons that the chilled water temperature is above this setpoint (e.g., chiller problem, control valve failure, etc.) This is the setpoint at which the HIGH CW TEMP alarm will be activated.

HI AIR TEMP

High Room Air Temperature Setpoint—This is the setpoint at which the HIGH REMOTE TEMP and HIGH LOCAL TEMP alarms will be activated.

LOW AIR TEMP

Low Room Air Temperature Setpoint—This is the setpoint at which the LOW REMOTE TEMP and LOW LOCAL TEMP alarms will be activated.

4.3.3 STATUS

The user can check the status of the control valve, pump operation, and refrigerant and chilled water temperature.

CONTROL VALVE—0-100%

PUMP 1—On/Off

PUMP 2—On/Off

REFRIG T—Refrigerant temperature 0-100° F

CW TEMP—Chilled Water temperature 0-100° F

4.3.4 ACTIVE ALARMS

This submenu allows the user to review any present alarms. If no alarms are present, the screen will read “No Alarms Present.” If any alarms are occurring, the screen will display “Alarm XX of YY,” followed by the alarm text (“XX” is the reference number of the alarm shown, “YY” is the total number of alarms).

If more than one alarm is present, use the Up or Down arrow keys to scroll through the alarms.

4.3.5 ALARM HISTORY

This submenu allows the user to review the 60 most-recent alarms. The first line of the screen will show the alarm number—01 being the newest—and the name of the alarm. The second line of the screen will show the most recent alarm’s date and the time in 24 hour format. Use the Up or Down arrow key to scroll through the alarm history list.

4.3.6 TIME

To change the time, press ENTER to select the function, then use the Up or Down arrow key to change the first character, press ENTER to store, then press the Up or Down arrow key to change the second character, press ENTER to store, etc.



NOTE

The clock uses the 24-hour system (for example, 17:00 would be 5:00 PM). The date and time are kept current even when the control board is not powered.

4.3.7 DATE

To change the date, press ENTER, then use the Up or Down arrow key to change the first character, press ENTER to store, press the Up or Down arrow key to change the second character, etc.

4.3.8 SETUP OPERATION



NOTE

None of these setpoints should be changed before consulting a Liebert representative. Changing any of these setpoints could drastically affect the system.

Selecting Setpoint/Setup from the Main Menu will display the following selections:

Table 9 Setup operation functions default values and allowable ranges.

Menu Item	Function	Default	Range
RESTART	Restart time delay	0.1 min	0 to 9.9 min (0 = manual restart)
C/F DEGREES	Celsius or Fahrenheit	F	C or F
PUMP START TD	Pump start time delay	10 sec	3 - 120 sec
PUMP WAIT TD	Pump wait time delay	10 sec	3 - 120 sec
PUMP OFF TD	Pump off time delay	5 sec	5 - 120 sec
LEAD PUMP	Lead Pump	Pump 1	Pump 1 / Pump 2
DIPSWCH	DIP switch status	NA	NA
VALVE TIME	Control valve travel time	60 sec	50 - 250 sec

Use the Up and Down arrow keys to scroll through the submenu, then press the ENTER button to access a function. To make changes or review the current setting, see **4.3.1 - Viewing or Changing Settings**.



NOTE

Setpoints and system setup parameters are kept in non-volatile memory.

RESTART TIME DELAY

This function specifies the time for the unit to restart after main power is restored to the unit. If several systems are operating, the time delays should be set to different values to cause a sequential start. Delay can be set from 0.1 minutes (6 seconds) to 9.9 minutes. Setting the value to "NO!" will prevent the unit from restarting when power is restored. In this case, the unit must be restarted manually by pressing the "On/Off" key.

To make changes or review the current setting, see **4.3.1 - Viewing or Changing Settings**.

C/F DEGREES

The control can be selected to show readings and setpoints in either degrees Fahrenheit (F) or Celsius (C). To make changes or review the setting, see **4.3.1 - Viewing or Changing Settings**.

PUMP START TD

The user may set a pump start time delay (in seconds) to ensure that refrigerant begins flowing when the pump starts. If refrigerant does not begin flowing before this delay expires, the pump will stop for a period that the user may also specify (see **PUMP OFF TD**). After this delay, the pump will again begin its startup sequence.

To make changes or review the current setting, see **4.3.1 - Viewing or Changing Settings**.

PUMP WAIT TD

The user may set the pump wait time delay to prevent the pump from continuing to run when refrigerant is not flowing. When the control detects a loss of refrigerant flow, the pump continues operating for the period specified in the PUMPWAIT TD.

If refrigerant flow resumes during the specified interval, the pump will continue operating. If the wait time expires and refrigerant flow has not resumed, the pump will shut down, activate an alarm for loss of flow to the pump and the second pump will be started.

To make changes or review the current setting, see **4.3.1 - Viewing or Changing Settings**.

PUMP OFF TD

The user can set the amount of time a pump will remain off when refrigerant flow is interrupted or stops. After the time delay has expired, the control will try to start a pump—unless there is a problem with the building chilled water system or if the refrigerant temperature sensor has failed.

To make changes or review the current setting, see **4.3.1 - Viewing or Changing Settings**.

LEAD PUMP

The user can select which pump is the lead pump, either pump #1 or pump #2. For example, if pump #1 is selected, it will be the primary pump and will switch to the standby pump (the pump that is not selected) on a loss of flow after a programmed time delay has elapsed.

To make changes or review the current setting, see **4.3.1 - Viewing or Changing Settings**.

DPSWCH

This menu displays the status of the eight-position DIP switch on the XDP control board. If a selector is beside the numeral “1,” the switch is On. If a selector is beside the numeral “0,” the switch is Off.

For proper operation, DIP switches 1-7 MUST be off and DIP switch 8 MUST be on.

Table 10 XDP DIP switches and factory settings

DIP Switch	Factory Setting
1	Off
2	Off
3	Off
4	Off
5	Off
6	Off
7	Off
8	On = XDP; Off = XDWP

VALVE TIME

This value is the number of seconds it takes the control valve to travel from fully closed to fully open. If the control loses the analog feedback position from the control valve, the control will close the valve, then calculate how long to open the valve for the current call for cooling.

For example, if VALVE TIME is set to 60 seconds and there is a 50% call for cooling, the valve will open for 30 seconds, leaving the valve halfway open. To make changes or review the current setting, see **4.3.1 - Viewing or Changing Settings**.

Scroll through this submenu by using the Up or Down arrow key. To make changes or review the current setting, see **4.3.1 - Viewing or Changing Settings**.

For example, to change the DEWPOINT MARGIN:

- a. From the main Status display, press MENU.
- b. Scroll to the SETPOINTS using the Up or Down arrow key.
- c. Press ENTER to select the SETPOINTS submenu.
- d. Scroll to DEWPOINT MARGIN using the Up or Down arrow key.
- e. Press ENTER
- f. Use the Up arrow key to increase the value or use the Down arrow key to lower the value.
- g. Press ENTER to store.



NOTE

Setpoints and system setup parameters are kept in non-volatile memory.

4.3.9 Password Security—SETPT PASSWORD and SERVICE PASSWORD

Setpoints, setup operations and alarm settings may be secured with three-digit passwords to prevent unauthorized changes. The password function for SETPT PASSWORD and for SERVICE PASSWORD is enabled by default. Passwords are enabled or disabled through DIP switch #8.

- To enable the password security feature, open the user interface display cover and set DIP switch #8 to the Off position, then close the cover.
- To disable the password security feature, open the user interface display cover and set DIP switch #8 to the On position, then close the cover.

Change Password—SETPT PASSWORD

The factory default SETPT PASSWORD is “123”—this password protects setpoints and some alarm settings. To change the SETPT PASSWORD:

1. Press the MENU key to display the Main Menu.
2. Use the Up or Down arrow keys to scroll to the SETPT PASSWORD function.
3. Press ENTER to access the SETPT PASSWORD function. The LCD will display three zeros (000).
4. Enter the present, three-digit password.
 - a. Use the Up or Down arrow key to enter the first number.
 - b. Press the ENTER button to select the second number in the password.
 - c. Use the Up or Down arrow key to enter the second number.
 - d. Enter the third number by repeating **Steps b and c**.
 - e. Press the ENTER button to accept the password. The LCD will display the message PASSWORD OK.
5. Press the ENTER button; the LCD displays the message ENTER NEW PSW and the current password. The first numeral will be selected.
6. Use the Up or Down arrow key to enter the first number of the new password. Press the ENTER button to select the second numeral in the password.
7. Use the Up or Down arrow key to enter the second number of the new password. Press the ENTER button to select the third numeral in the password.
8. Use the Up or Down arrow key to enter the third number of the new password. Press the ENTER button to save the new password.

Change Password—SERVICE PASSWORD

The factory default SERVICE PASSWORD is “123”—this password protects setup operations and more-critical alarm settings. To change the SERVICE PASSWORD:

1. Press the MENU key to display the Main Menu.
2. Use the Up or Down arrow key to scroll to the SERVICE PASSWORD function.
3. Press ENTER to access the SERVICE PASSWORD function. The LCD will display three zeros (000).
4. Enter the present, three-digit password.
 - a. Use the Up or Down arrow key to enter the first number.
 - b. Press the ENTER button to select the second number in the password.
 - c. Use the Up or Down arrow key to enter the second number.
 - d. Enter the third number by repeating **Steps b** and **c**.
 - e. Press the ENTER button to accept the password. The LCD will display the message PASSWORD OK.
5. Press the ENTER button; the LCD displays the message ENTER NEW PSW and the current password. The first numeral will be selected.
6. Use the Up or Down arrow key to enter the first number of the new password. Press the ENTER button to select the second numeral in the password.
7. Use the Up or Down arrow key to enter the second number of the new password. Press the ENTER button to select the third numeral in the password.
8. Use the Up or Down arrow key to enter the third number of the new password. Press the ENTER button to save the new password.

4.3.10 CALIBRATE SENSOR

The local and the remote temperature and humidity sensors can be calibrated by selecting this menu item. The temperature sensor can be calibrated $\pm 5^{\circ}\text{F}$ and the humidity sensor can be calibrated $\pm 10\%$ RH. To prevent coil condensation that could damage the XDP, the sensors must be calibrated to a known source.

4.3.11 ALARM ENABLE

Some alarms can be disabled or enabled as part of the user’s customized setup. An alarm that has been disabled will not report to the wall box beeper nor to the common alarm relay. Alarms are enabled by default.

Use the Up or Down arrow key to select a particular alarm; “YES” enables the alarm, “NO” disables the alarm. Press ENTER to save the change.

4.3.12 ALARM TIME DELAY

Some alarms can be programmed with a time delay as a means of preventing nuisance alarms. This function specifies the amount of time an alarm must be present before the XDP recognizes and annunciates the alarm. If the alarm condition goes away before the time delay has expired, the alarm will not be recognized, and the time delay timer will be reset.

4.3.13 COM ALARM ENABLE

Each individual alarm can be selected to energize or not to energize the common alarm relay. If the energize common alarm function is set to YES, the relay is energized immediately as the alarm is annunciated and de-energized when the alarm condition goes away (only after the alarm has been recognized). If the alarm is completely DISABLED, the alarm has no effect on the common alarm relay.

Use the Up or Down arrow key to scroll to a particular alarm, press the ENTER button to select it, then press the ENTER button to change the state (Yes or No).

4.3.14 CUSTOM ALARMS

This is the menu where the user selects the alarm message that will be displayed when there is an input to the customer alarm input on the control board. This menu has four choices: one user-defined custom message (see **CUSTOM TEXT** below for details) and three preprogrammed messages:

- SMOKE DETECTED
 - CUSTOM 1 (default custom message. If the user enters a custom text message, that custom text will replace “CUSTOM 1.”)
 - WATER FLOW LOSS
 - STANDBY UNIT ON
1. Press the ENTER button to access the menu
 2. Use the Up or Down arrow key to view the messages.
 3. Press the ENTER button to select the message to be displayed.

4.3.15 CUSTOM TEXT

This menu permits the user to set up a custom text message with a maximum length of 16 characters. The message may use any of the following characters or a blank space:

ABCDEFGHIJKLMNOPQRSTUVWXYZ#%*-0123456789

This custom text can be designated as the custom alarm text in the “CUSTOM ALARMS” menu (see **CUSTOM ALARMS** above). To define the message:

1. Press the ENTER button to access the menu.
2. Use the Up or Down arrow key to change the character with the pointer below it.
3. Press the ENTER button to go to the next character.
4. Repeat the steps for all characters in the message (maximum of 16 characters).
5. Press the ENTER button to accept new custom text.

4.3.16 DIAGNOSTICS

This allows the user to perform checks on inputs, outputs, and conduct a test of the XDP control board from the wall box.

Entering the “TEST OUTPUTS” will interrupt system operation. Selecting “TEST INPUTS” or “TEST MICRO” will not interrupt system operation. Pressing ENTER and selecting “TEST OUTPUTS” will permit the user to toggle the following outputs On and Off:

PUMP 1—On/Off
 PUMP 2—On/Off
 CTR VALVE XX.Xma—OPEN/CLOSE (control valve and 4-20mA feedback signal)
 GREEN LAMP—On/Off
 RED LAMP—On/Off
 COMMON ALARM—On/Off

Pressing ENTER and selecting “TEST INPUTS” will permit the user to read the following inputs:

INPUT POWER—On/Off
 CONDENSATION—On/Off (condensation detection)
 DIFF PRESSURE—On/Off (differential pressure switch)
 CUSTOMER ALARM—On/Off

Pressing ENTER and selecting “TEST MICRO” will permit the user to test the microcontroller and associated circuitry on the XDP control board.

5.0 ALARM DESCRIPTIONS AND SOLUTIONS

5.1 Alarm Descriptions



NOTE

*Alarms **must be acknowledged** before they can be reset. To acknowledge or silence an alarm, press the ALARM SILENCE / ? key.*

- **LOSS OF FLOW P1**—Activated when Pump 1 is commanded to run and the differential pressure switch does not sense differential pressure (set at 6 psi; 41kPa; 0.41 bars). After attempting to start Pump 1 for 120 seconds (including time delays), the XDP will automatically switch to the other pump to establish flow.
- **LOSS OF FLOW P2**—Activated when Pump 2 is commanded to run and the differential pressure switch does not sense differential pressure (set at 6 psi; 41kPa; 0.41 bars). After attempting to start Pump 2 for 120 seconds (including time delays), the XDP will automatically switch to the other pump to establish flow.
- **SHORT CYCLE**—Activated when the XDP is trying to establish flow (differential pressure), and it is unable to do it. The XDP will attempt to establish flow for 4 minutes on each pump, for a total of 8 minutes. If this “cycling” occurs within 30 minutes and the XDP still does not establish flow, a SHORT CYCLE alarm will be present. This alarm will shut down the XDP. Main power (disconnect switch) must be turned Off, then back On to clear this alarm. The cycling time for the SHORT CYCLE alarm can be adjusted from the default of 30 minutes; the range is from 10 minutes to 60 minutes.
- **CONDENSATION!**—Activated when water is detected at the XD cooling module (24VAC is applied to the condensation input on the control). When this alarm is active, the control will raise its refrigerant control point by 4°F (-16°C). Alarm will reset when the 24VAC signal ends or main power is removed.
- **VALVE FAILURE**—Activated when the chilled water control valve has been commanded by the control to open or close and no change is detected from the valve-position signal. The control will close the valve and then try to control the control valve based on its travel time. Main power (disconnect switch) must be turned Off, then back On to clear this alarm.
- **CUSTOMER ALARM**—Activated when 24VAC signal is applied to the customer alarm input on the control board. Alarm will reset when the 24VAC signal is taken away.
- **HIGH CW TEMP**—Activated when entering chilled water temperature exceeds the user specified setpoint. The alarm will reset itself when the entering chilled water temperature drops below the setpoint.
- **FAILED CW SENSOR**—Activated when the control stops receiving a signal from the entering chilled water temperature sensor. The alarm will reset itself when the temperature sensor signal is re-established.
- **HIGH REMOTE TEMP & HIGH LOCAL TEMP**—Activated when the remote or local temperature exceeds the user specified setpoint. The alarm will reset itself when the room temperature drops below the setpoint.
- **LOW REMOTE TEMP & LOW LOCAL TEMP**—Activated when the remote or local temperature is below the user-specified setpoint. The alarm will reset itself when the room temperature raises above the setpoint.
- **REMOTE SENS PROB**—Activated when no signal is present from the remote temperature or humidity sensors. Alarm will reset when the temperature and humidity signals are re-established.
- **LOCAL SENS PROB**—Activated when no signal is present from the local temperature or humidity sensors or when communication with the display is lost. The alarm will reset when the temperature and humidity signals are re-established.
- **HIGH REFRIG TEMP**—Activated when the refrigerant temperature exceeds the user-specified setpoint. The alarm will reset itself when the refrigerant temperature drops below the setpoint.
- **LOW REFRIG TEMP**—Activated when the refrigerant temperature drops 1.5°F (1°C) below the refrigerant temperature control point. The alarm will reset itself if the refrigerant temperature rises before the control shuts down because of low refrigerant temperature.

- **REFRIG SENS FAIL**—Activated when the control stops receiving a signal from the refrigerant temperature sensor. If this alarm becomes active, the control will close the control valve over a 9-minute period. This alarm will shut down the XDP. Main power must be (disconnect switch) must be turned Off, then back On to clear this alarm.
- **LOSS OF POWER**—Activated when the unit is On and operational and 24VAC power to the control is lost. This alarm will be emitted when power is restored to the control. The XDP will restart at a user-defined time delay after power is restored. The alarm will reset itself after 30 seconds of run time.

5.2 Red and Green Lamp Indicators

- The Green lamp will be on only when The XDP is On and running with no alarms.
- The Red lamp will be on if the unit is On and running with an active alarm, or if the unit is shut down because of a certain alarm.
- The Red lamp will flash when an alarm is being annunciated. The Red lamp will stop flashing and the beeper in the display will stop beeping when the ALARM SILENCE / ? key is pressed.

5.3 Alter Alarm Settings

5.3.1 Enable or Disable Alarms

At the user's discretion, some alarms may be enabled or disabled. If an alarm is disabled, the alarm condition will not be monitored and will not trip, will not be in ACTIVE ALARMS, will not be in ALARM HISTORY and will not be annunciated.

These alarms may be enabled or disabled:

- LOSS OF FLOW P1—loss of refrigerant flow with Pump 1 alarm
- LOSS OF FLOW P2—loss of refrigerant flow with Pump 2 alarm
- VALVE FAILURE—chilled water control valve failure alarm
- CUSTOMER—customer alarm
- HI RMT TEMP—high remote temperature alarm
- LO RMT TEMP—low remote temperature alarm
- HI LCL TEMP—high local temperature alarm
- LO LCL TEMP—low local temperature alarm

To determine whether an alarm is enabled or disabled:

1. Press the MENU key.
2. Use the Up and Down arrow keys to move to the ALARM ENABLE menu.
3. Press the ENTER key to access the menu. Use the Up and Down arrow keys to move through the menu and view which alarms are enabled or disabled. (“YES” means that the alarm is enabled, “NO” means that the alarm is disabled.)

To change an alarm from enabled to disabled, or vice versa

1. Determine whether the alarm is enabled or disabled (see above).
2. Use the Up and Down arrow keys to scroll to the alarm to be changed.
3. Press the ENTER key. (The control will ask for a service password if passwords are enabled. Use the Up and Down arrow keys and ENTER key to enter the three-digit password.)
4. Press the ENTER key again to change the alarm.
5. Press the ESC key two to three times to return to the main display.

5.3.2 Increase or Decrease Alarm Time Delays

An alarm time delay is the time that the a condition must exist before the control activates an alarm for that condition. This can be used as a filter to prevent nuisance alarms from transient events.

These alarms may have their time delays changed:

- CUSTOMER—customer alarm
- HIGH CW TEMP—high chilled water temperature alarm
- HI RMT TEMP—high remote temperature alarm
- LO RMT TEMP—low remote temperature alarm
- HI LCL TEMP—high local temperature alarm
- LO LCL TEMP—low local temperature alarm
- LOW REFRIG TEMP—low refrigerant temperature alarm

To view the time delay for an alarm:

1. Press the MENU key.
2. Use the Up and Down arrow keys to move to the ALARM TIME DELAY menu. Press the ENTER key to enter into the menu. Use the Up and Down arrow keys to move through the menu and view the alarm time delays.

To change the time delay for an alarm:

1. Press the ENTER key. (The control will ask for a service password if passwords are enabled. Use the Up and Down arrow keys and ENTER key to enter the three-digit password when prompted.)
2. Press the ENTER key again on the alarm to select the alarm to be changed.
3. Use the Up and Down arrow keys to change the alarm time delay.
4. Press the ENTER key to record the change.
5. Press the ESC key two to three times to return to the main display.

5.4 System Shutdown Causes

Unit Is Off By Refrig Sens Fail

The control has lost its signal from the refrigerant temperature sensor. The control has no way of controlling the refrigerant temperature, so the unit is shut off. Main power (disconnect switch) must be turned Off, then back On to clear this alarm.

Unit Is Off By High CW Temp

The entering chilled water temperature is too high to keep the refrigerant pump(s) running normally. If there is a HIGH CW TEMP alarm and the refrigerant pump loses flow (differential pressure), the XDP will immediately attempt to restart the pumps and re-establish flow. If flow is still not established, then the XDP will go into a pre-chill mode. The XDP can attempt to start again only if the entering chilled water temperature drops below the HIGH CW TEMP setpoint.

Unit Is Off By Pump Short Cycle

The control was unable to get a pump started upon startup or after a loss of differential pressure. The control looks at the SHORT CYCLE time delay. If it cannot establish differential pressure within that amount of time, the unit is shut down. This time is adjustable through the SHORT CYCLE alarm time delay. Main power (disconnect switch) must be turned Off, then back On to clear this alarm.

Unit Is Off By Low Refrig Temp

The control was unable to raise the refrigerant temperature to the calculated refrigerant temperature control point. The unit is shut down because if the control cannot raise the refrigerant temperature to the calculated refrigerant temperature control point, water may condense on the refrigerant piping and receiving coils. Main power (disconnect switch) must be turned Off, then back On to clear this alarm.

6.0 TROUBLESHOOTING

Symptom	Possible Cause	Check or Remedy
Pump will not energize	No main power	Check L1, L2 and L3 for rated voltage.
	Loose electrical connections	Tighten connections.
	Overloads tripped	Allow pump to cool. Check amp draw.
	Tripped circuit breaker	Check circuit breaker to pump(s).
	Incorrect phase wiring	See Table 6 .
Pump will not run	No chilled water	Check and verify that there is supply chilled water to the XDP.
	Isolation valve(s) on pump suction and/or discharge is closed.	Open all isolation valves completely during normal operation.
	Supply chilled water is too high	Check and verify that the chilled water temperature setpoint is at 50°F (10°C) or lower and that there is flow on the chilled water side.
	XD cooling modules are Off	Check XD cooling module to make sure that they are On prior to starting the XDP.
	Low Refrigerant Temperature (high dew point)	Check alarm(s) history on XDP. The XDP was operating below the dew point for a significant amount of time. Check humidity in conditioned space, lower humidity if necessary to allow XDP to operate at a lower temperature. (Disconnect must be switched to Off then back On to allow XDP to reset itself).
	Incorrect location of temperature-humidity sensors	Place the sensor on the RETURN AIR side of the primary air mover (e.g., Liebert Deluxe System 3). Do not install the sensor near unsealed doors, windows and similar areas.
	Pressure switch not making contact	Check both differential pressure settings. If not within 6 psi, ±1 psi (41kPa, ±7kPa; 0.41 bars, ±0.07bars) then manually change accordingly.
	Not enough charge	See 3.0 - Checklist for XDP Startup .
Pump noisy	Cavitation due to vapor in pump	Check for adequate charge in system, refer to the User's Manual. 3.0 - Checklist for XDP Startup
	Worn motor bearings	Replace pump
XDP (Pump) suddenly stops	Low Refrigerant Temperature (High dew point)	Check humidity of room along with location of remote sensors. Make sure that the sensors are not located in a cold area where there is a lack of sufficient air flow.
	Clogged filter/dryer and/or impeller	Clean out debris.
Pipe rattle	Loose pipe connections	Check pipe connections
Chilled water valve not working	Motor operates but valve won't open	Check linkage for adjustment and be sure that it is tight on the valve.
Actuator motors	No 24 VAC power to motor	Check for 24 VAC between P2-1 and P2-4.
	No signal from control	Check 24 VAC at P22-1 (close) or P22-3 (open).
	Motor not operating	Unplug P22 completely off of the board. Jumper P22-5 to P2-4 for grounding, then jumper P22-1 to P2-1 to drive close. Remove jumper to close, and then jumper P22-3 to P2-1 to drive open. If motor fails to work, replace it.
Motor burnout	Check control panel for welded contactor contacts or welded overload contacts	Replace defective components.
Main 24 VAC fuse trips	Shorts or loose connections	Check the wiring connections of the 24 VAC circuit.
	Faulty circuit board	Replace the circuit board.

7.0 MAINTENANCE

The Liebert XD system components require little maintenance when proper fluid levels are maintained and proper startup and operation procedures are followed. The following tasks should be performed at the intervals stated:

1. Clean or replace chilled water strainer annually. Adjust accordingly based on purity of chilled water.
2. Check sight glass level of receiver every 4-6 weeks. During normal operation, the level should be at or above the second sight glass.
3. Check system for leaks every 4-6 weeks.

8.0 SPECIFICATIONS

Table 11 Liebert XDP specifications

Models	XDP160RC--1	XDP160RA--1	XDP160RM--1
Cooling Capacity, Nominal	160kW / 46 Tons, 60Hz		140kW / 40 Tons, 50Hz
	Each capacity is based on 45°F (7°C) entering water temperature and 140gpm (530lpm) water flow rate. Capacity is reduced when glycol mixtures are used in place of 100% water.		
Electrical Requirements			
Input	208V/3ph/60Hz	460V/3/ph60Hz	380/415V/3ph/50Hz
Full Load Amps	4A	2.1A	2.3A
Dimensions, inches (mm)			
Height – Unit only	78 (1981)		
Height – As shipped	83 (2108)		
Width	38 (965)		
Depth	34 (864)		
Weight, lb (kg)			
Unit only	821 (372)		
Shipping weight	Domestic: 990 (449); Export: 1067 (484)		
Installed, with refrigerant and chilled water	1038 (471)		
Pipe Connections			
Refrigerant supply to XD cooling module	1-1/8" OD, Cu		
Refrigerant return from XD cooling module	2-1/8" OD, Cu		
Chilled water supply and return	2-5/8" OD, Cu		
Control valve	2-way, 2" nominal		
Pressure Drop – Chilled Water Side	20 psig (137kPa, 1.38bar), with 140 gpm (530lpm) water flow rate, control valve fully open		
Temperature Rise – Chilled Water Side at rated flow, °F (°C)	8.0 (4.4)		6.9 (3.8)
Number of XD cooling units connected, maximum (minimum)			
XD CoolFrame10	16 (4)		
XDH20	8 (2)		
XDH32	5 (1)		
XDV8	20 (4)		
XDV10	16 (4)		
XDO16	10 (2)		
XDO20	8 (2)		
Cabinet Exterior Finish	Black, matte finish, heat-fused powder coat		
Operating Ambient Temperature, Maximum, °F (°C)	86 (30)		
Agency			
Approvals	CSA 60Hz		CE 50Hz

NOTES

Ensuring The High Availability Of Mission-Critical Data And Applications.

Emerson Network Power, the global leader in enabling business-critical continuity, ensures network resiliency and adaptability through a family of technologies—including Liebert power and cooling technologies—that protect and support business-critical systems. Liebert solutions employ an adaptive architecture that responds to changes in criticality, density and capacity. Enterprises benefit from greater IT system availability, operational flexibility and reduced capital equipment and operating costs.

Technical Support / Service Web Site

www.liebert.com

Monitoring

800-222-5877

monitoring@emersonnetworkpower.com

Outside the US: 614-841-6755

Single-Phase UPS

800-222-5877

upstech@emersonnetworkpower.com

Outside the US: 614-841-6755

Three-Phase UPS

800-543-2378

powertech@emersonnetworkpower.com

Environmental Systems

800-543-2778

Outside the United States

614-888-0246

Locations

United States

1050 Dearborn Drive

P.O. Box 29186

Columbus, OH 43229

Europe

Via Leonardo Da Vinci 8

Zona Industriale Tognana

35028 Piove Di Sacco (PD) Italy

+39 049 9719 111

Fax: +39 049 5841 257

Asia

7/F, Dah Sing Financial Centre

108 Gloucester Road, Wanchai

Hong Kong

852 2572220

Fax: 852 28029250

While every precaution has been taken to ensure the accuracy and completeness of this literature, Liebert Corporation assumes no responsibility and disclaims all liability for damages resulting from use of this information or for any errors or omissions.

© 2006 Liebert Corporation

All rights reserved throughout the world. Specifications subject to change without notice.

® Liebert and the Liebert logo are registered trademarks of Liebert Corporation. All names referred to are trademarks or registered trademarks of their respective owners.

SL-16641_REV6_11-06

Emerson Network Power.

The global leader in enabling Business-Critical Continuity™.

■ AC Power

■ Embedded Computing

■ Outside Plant

■ Racks & Integrated Cabinets

■ Connectivity

■ Embedded Power

■ Power Switching & Controls

■ Services

■ DC Power

■ Monitoring

■ Precision Cooling

■ Surge Protection

Business-Critical Continuity, Emerson Network Power and the Emerson Network Power logo are trademarks and service marks of Emerson Electric Co.

©2006 Emerson Electric Co.