

GXT RT Series 1-3 kVA UPS

User Manual

Version: V1.11
Revision date: Sept 21, 2005



Emerson Network Power provides customers with technical support. Users may contact the nearest Emerson local sales office or service center.

While every precaution has been taken to ensure accuracy and completeness in this manual, Emerson Network Power assumes no responsibility and disclaims all liability for damages resulting from use of this information or for any errors or omissions.

Emerson Network Power pursues a policy of continuous product development and reserves the right to change the equipment design without notice.

Copyright © 2005 by Emerson Network Power

All rights reserved. The contents in this document are subject to change without notice

Contents

Safety Instructions.....	3-4
Description of Commonly used Notations.....	5
1 Product Description	6
1.1 Features.....	6
1.2 System Components	6
1.2.1 Power Module	6
1.2.2 Battery Module.....	8
1.3 System Type And Configuration	9
1.4 Operating Principle	10
1.5 Communication.....	11
2 Installation.....	12
2.1 Unpacking Inspection	12
2.2 Installation Notes	12
2.3 Tower Installation	13
2.3.1 Installing Single Power Module.....	13
2.3.2 Installing Power Module Plus Battery Module.....	13
2.4 Rack Installation	14
2.4.1 Installing Single Power Module.....	14
2.4.2 Installing Power Module Plus Battery Module.....	15
2.5 Cable Connection	15
2.5.1 Connecting Battery Cable	15
2.5.2 Connecting Input And Output Cables.....	16
2.5.3 Connecting Communication Cable	16
3 Operation	18
3.1 Operator Control And Display Panel.....	18
3.2 Operation Mode	20
3.3 Operating Instructions.....	20
3.3.1 Turning On And Completely Powering Down The UPS ..	20
3.3.2 Conducting Battery Test.....	21
4 Maintenance	22
4.1 Battery Maintenance.....	22
4.2 Replacing Output Fuse	22
4.3 Checking UPS Functions.....	22
4.4 Troubleshooting	23
5 Specifications.....	25
5.1 Mechanical.....	25
5.2 Electrical	25
5.3 EMS	26
5.4 EMI	27
5.5 Environmental	27
5.6 Safety.....	27



Safety Instructions

Caution - risk of electric shock. Even after the unit is disconnected from the mains power supply (building wiring socket outlet), components inside the UPS system are still connected to the battery and are still electrically live and dangerous.













Before carrying out any kind of servicing and/or maintenance, disconnect the batteries and verify that no current is present and no hazardous voltage exists in the terminals of high capacity capacitors such as BUS-capacitors

- As dangerous voltages are present within the UPS, only an Emerson technician or an Emerson-authorized technician is permitted to open it. Failure to observe this could result in electric shock risk and invalidation of any implied warranty.
- When the UPS is purchased to deliver power to the equipment listed below, please discuss with the Emerson or Emerson Authorized Representative in advance about the applicability, settings, management and maintenance of the UPS.
- The Liebert GXT-RT has been designed for Commercial/Industrial use only, and is not recommended for use in life support applications
- Never dispose of the battery in a fire, as it may explode when exposed to flame.
- Do not apply pure inductive load to the UPS.
- The UPS has its own energy source (i.e., a battery), therefore the output terminal of the UPS may carry live voltage even when the UPS is not connected to the AC mains.
- Before moving or re-wiring the UPS, please disconnect the mains source and make sure the UPS is completely shut down. Otherwise the output terminal may carry live voltage, presenting risk of electric shock.
- To ensure safety and normal operation, the UPS must be solidly and adequately grounded before use.
- The operating environment and storage method are two main factors affecting the lifetime and reliability of the UPS. Hence, it is advisable not to use the UPS for longer periods in the following environments:
 - Places where the temperature and relative humidity are outside the specifications (specified temperature: 0°C~40°C, specified relative humidity: 5%~95%);
 - Places where vibrations or shocks exist;
 - Places which are dusty, strewn with corrosive substances or salts or where flammable gases are present.
- Verify that the cabling and battery cable polarity are correct before switching on the UPS.
- The external battery must be fitted with an appropriate overcurrent protection device.
- The UPS installation must be firm and solid. The AC input socket that feeds the UPS should be located near the UPS, and easy to access.

- In case of fire, use dry chemical fire extinguisher to put out the fire. Using foam fire extinguisher may cause electric shock.
- High ambient temperature shortens the battery's lifetime, so the battery should be monitored & maintained periodically and if required should be replaced. This is to ensure normal UPS operation and adequate autonomy time. Only an Emerson-authorized technician is permitted to replace the battery. In replacement of battery or battery module, please use the same model and number of battery or battery module.
- It is recommended to place battery at a place with controlled ambient temperature. The rated battery performance is available at 25 degree Celsius.
- Do not open or damage the battery, as the battery electrolyte is harmful to the eyes and the skin. If electrolyte comes into contact with the skin, wash the affected area with plenty of clean water and seek emergency medical assistance immediately

Description of commonly used notations

Some or all of the following Notations may be used in this manual and may appear in your application process. Therefore, all users should be familiar with them and understand their explanations.

Notation and Explanation	
Notation	Explanation
	Alert you to pay special attention
	Caution of high voltage
	Turn on the UPS
	Turn off the UPS
	Idle or shut down the UPS
	Alternating current source (AC)
	Direct current source (DC)
	Protective ground
	Alarm silence
	Overload indication
	Battery check
	Recycle
	Keep UPS in a clear area

Product Introduction

The GXT-RT series 1~3kVA UPS is an online UPS with a sine wave output, and is developed by Emerson Network Power.

The GXT-RT provides highly efficient and reliable AC Power for your sensitive equipment.

The GXT-RT adopts a modular design. Rack installation and tower installation can be used depending on the user's requirements. It is an ideal product for applications that require small footprint, like communication stations and data machine rooms.

1.1 Features

Product features include:

- 2U thick.
- Exceptional electrical performance, with an on-line efficiency up to 88%.
- High system reliability, self-protection and fault diagnosis are achieved using the advanced DSP-based full digital control technology.
- The system adopts a high-frequency, double conversion topology structure to achieve a high input power factor up to 0.99, greatly reducing its contamination to the power grids.
- With a wide range of input voltages, and an output immune to the mains interference, the product is suitable even for areas with unstable mains power supply. It is an environmentally efficient energy source.
- With a wide range of input frequencies, the product can be well connected to the generator output.
- Long Back up model has built-in large charger to satisfy users' demand for extended battery back-up time.

1.2 System Components

Power module and battery module are the basic components of GXT RT series UPS. The former performs power conversion, provides AC output for load and charges the battery, while the latter provides DC power for the UPS.

1.2.1 Power Module

Types and models

There are two types of power module: standard type and extended back-up time type, each available in the following ratings: 1kVA, 2kVA and 3kVA.

The power module types and models appear from Table 1-1. Users can confirm the module model by checking the nameplate on the enclosure.

Table 1-1 Power module types and models

Type	Module name	Model	Remark
Standard	1kVA standard power module	GXT1000-RT	With a 1A internal charger and a 3*12V/7.2Ah internal battery
	2kVA standard power module	GXT2000-RT	With a 1A internal charger
	3kVA standard power module	GXT3000-RT	With a 1A internal charger
Extended back-up time	1kVA extended back-up time power module	GXT1000L-RT	With a 7A internal charger
	2kVA extended back-up time power module	GXT2000L-RT	With an 8A internal charger
	3kVA extended back-up time power module	GXT3000L-RT	With an 8A internal charger

Front panel appearance

All models of power modules have the same front panel, which provides ON/Alarm silence button, OFF button and LED indication, as shown in Figure 1-1.

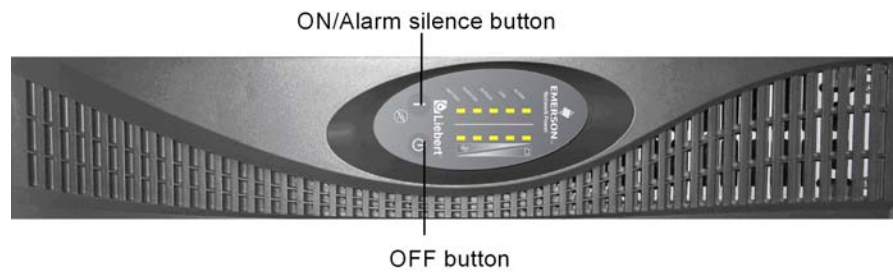

Figure 1-1 Front panel of power module

Rear panel appearance

The power module's rear panel differs with the model, as shown in figures from 1-2 to 1-6. The rear panel provides AC input socket, AC input overcurrent protection switch, output socket, output fuse and output terminal block (3kVA power modules only), external battery socket (except for 1kVA standard power module), DB9 communication port and SNMP card slot.

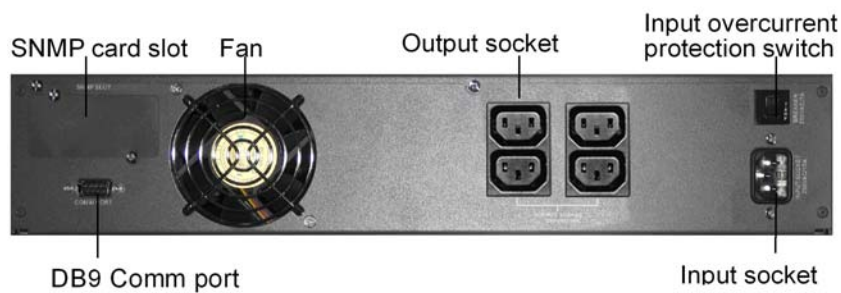

Figure 1-2 Rear panel of 1kVA standard power module

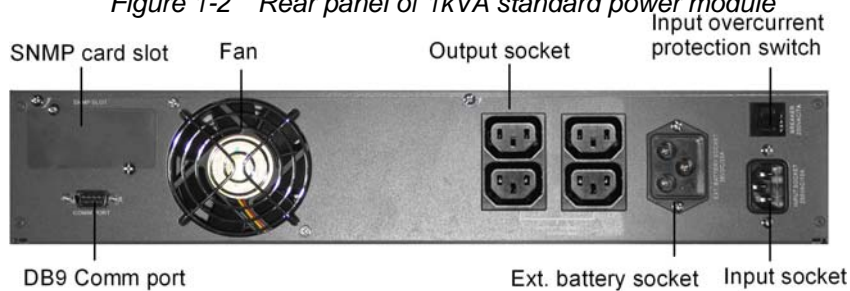

Figure 1-3 Rear panel of 1kVA extended back-up time power module

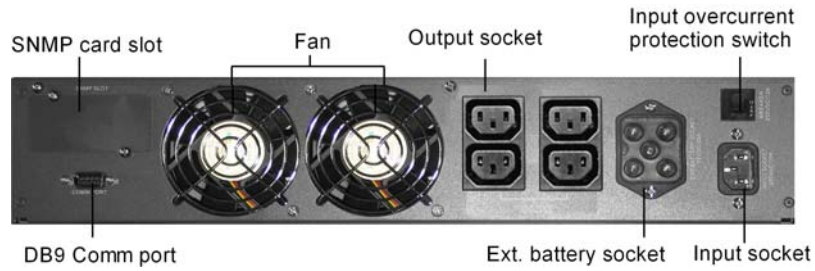

Figure 1-4 Rear panel of 2kVA standard power module

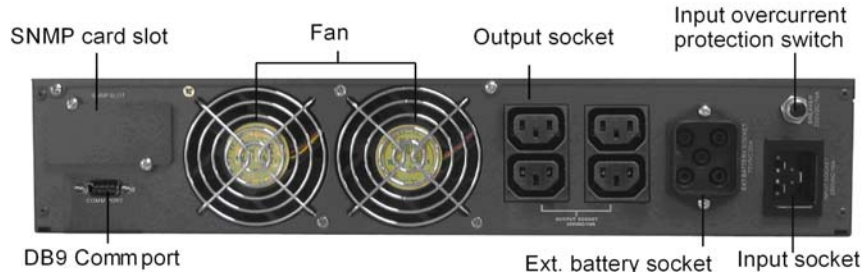

Figure 1-5 Rear panel of 2kVA extended back-up time power module

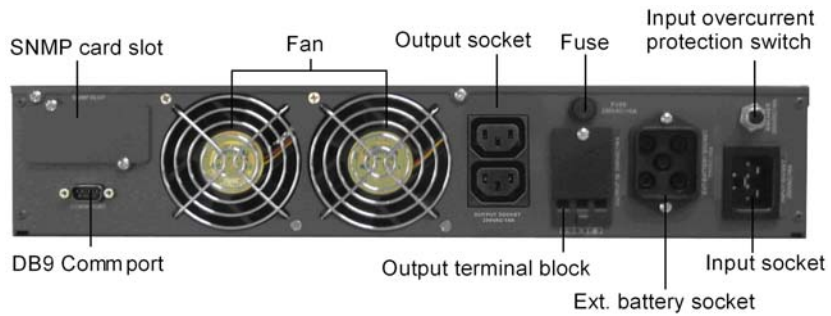

Figure 1-6 Rear panel of 3kVA power modules

1.2.2 Battery Module

Model

The battery packs are available in two modules: GXT2000-BAT and GXT3000-BAT, as shown in Table 1-2. Users can confirm the module model by checking the nameplate on the enclosure.

Table 1-2 Battery module models

Module name	Model	Remark
72V/7.2Ah battery module	GXT2000-BAT	72V, with a 6*12V/7.2Ah internal battery
72V/9.0Ah battery module	GXT3000-BAT	72V, with a 6*12V/9Ah internal battery

Front panel and rear panel appearances

The GXT2000-BAT and GXT3000-BAT battery modules have the same front panel and rear panel, as respectively shown in Figure 1-7 and Figure 1-8.



Figure 1-7 Front panel of battery module



Figure 1-8 Rear panel of battery module

1.3 System Type And Configuration

The above mentioned power modules and battery modules can comprise two types of UPS system: standard type and extended back-up time type, each available in the following ratings: 1kVA, 2kVA and 3kVA UPS.

The UPS types and configurations appear from Table 1-3.

Table 1-3 UPS types and configurations

UPS type		Configuration			
		Module	Model	Qty.	Remark
Standard	1kVA standard UPS	Power module	GXT1000-RT	1	The UPS has only one power module
	2kVA standard UPS	Power module	GXT2000-RT	1	The UPS consists of a power module and a battery module
		Battery module	GXT2000-BAT	1	
	3kVA standard UPS	Power module	GXT3000-RT	1	
Battery module		GXT3000-BAT	1		
Extended backup time	1kVA extended back-up time UPS	Power module	GXT1000L-RT	1	External battery is needed and should be provided by users. Emerson battery and battery cabinet are recommended
	2kVA extended back-up time UPS	Power module	GXT2000L-RT	1	
	3kVA extended back-up time UPS	Power module	GXT3000L-RT	1	

1.4 Operating Principle

The UPS operating principle is shown in Figure 1-9.

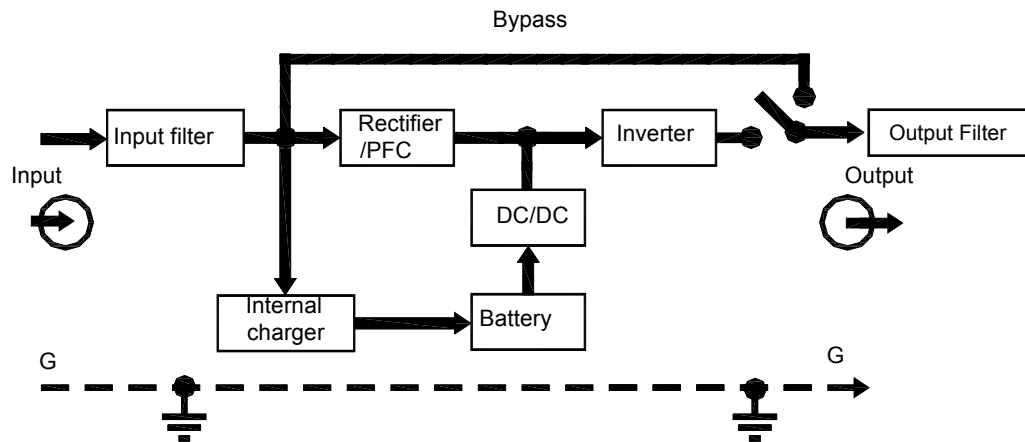

Figure 1-9 UPS schematic block diagram

The UPS comprises AC input, input filter (EMI and Class D Surge Protecting Device), rectifier/PFC (power factor correction), DC/DC converter, inverter, bypass, internal charger, battery and UPS output functional modules. The UPS uses DSP (digital signal processor) and IGBT (insulated gate bipolar transistor) to ensure satisfactory performance and increase the product reliability.

AC input: contains AC input socket and input overcurrent protection switch.

Input filter: contains EMI suppression filter and Class D SPD. It provides clean AC power to the UPS.

Rectifier/PFC: an important front-end processing functional module of the UPS. In Normal mode, the rectifier/PFC circuit converts the AC input power to regulated DC power, while ensuring that the wave shape of the input current used by the UPS is near ideal.

DC/DC converter: it raises the DC voltage from the battery system to the optimum operating voltage for the inverter when the UPS operates in Battery mode.

Inverter: an important back-end processing functional module of the UPS. In Normal mode, the inverter utilizes the DC output of the PFC circuit and inverts it into precise, regulated sinewave AC power. In Battery mode, the inverter receives its required energy from the battery through the DC/DC converter.

Bypass: this module plays a very important role in enhancing the UPS reliability. In the event of an UPS fault that will not lead to UPS shutdown, such as an over-temperature condition, rectifier fault, inverter fault, the load will be automatically transferred to the bypass. In the meantime, the LED indicators will indicate the fault type, and the fault information will be reported through the communication ports.

Internal charger: the internal charger of GXT1000-RT, GXT2000-RT and GXT3000-RT standard power modules provides 1A charging current; that of GXT1000L-RT extended back-up time power module provides 7A charging current; and that of GXT2000L-RT and GXT3000L-RT extended back-up time power modules provides 8A charging current.

Battery: Sealed maintenance-free lead-acid battery is used as the DC source of the UPS.

UPS output: this module contains output EMI suppression filter and provides multiple AC outputs for load.

1.5 Communication

The UPS provides a DB9 port and an SNMP card slot located on the rear panel of the power module (see figures from 1-2 to 1-6).

DB9 port

The DB9 can be used for RS232 serial communication and dry contact communication. Users can use the accessory UPS monitoring software to monitor the UPS through the DB9 port.

SNMP card slot

The SNMP card slot is designed for installing the SNMP card option, which enables users to monitor the UPS over network. It is also used for auto-shut down of computers in a network. Please consult Emerson representative for detailed monitoring options that are available for this UPS product.

Chapter 2 Installation

2.1 Unpacking Inspection

1. Open the packing box of each module and take out the modules, visually examine the modules for possible transit damage.
2. Check against the accessory lists (see tables 2-1 to 2-2) if the accessories of the power module and battery module are present.
3. If the UPS arrives damaged, or if there is any missing accessory, please contact the distributor immediately.

Table 2-1 Power module accessory list

Accessory	Quantity	Unit
Tower installation fittings — plastic support base	4	Pcs
Rack installation fittings — bracket	1	Pair
AC input cable	1	Pcs
Battery connection cable (as applicable)	1	Pcs
RS232 cable	1	Pcs
User manual	1	Pcs
Single UPS monitoring software CD	1	Pcs

Note:

1. The rated current of the AC input cable of GXT1000-RT, GXT1000L-RT and GXT2000-RT power modules is 10A. That of GXT2000L-RT, GXT3000-RT and GXT3000L-RT power modules is 16A.
2. Only long back-up time power modules are delivered with a battery connection cable--a 1.8m long cable with OT terminals attached to one end and a connector attached to the other, which is a 3-pin one for GXT1000L-RT module and a 5-pin one for GXT2000-RT and GXT3000L-RT modules.

Table 2-2 Battery module accessory list

Accessory	Quantity	Unit
Tower installation fittings — plastic middle base	2	Pcs
Rack installation fittings — bracket	1	Pair
Battery cable with a 5-pin connector attached to each end	1	Pcs

2.2 Installation Notes

1. When locating the UPS, make sure there is no hazardous objects around the UPS, and that the installation environment meets the specifications (see section 5.5).
2. The UPS is cooled with the aid of the internal fan fitted in the back of the power module. A clearance of at least 300mm should be maintained behind the power module to facilitate adequate ventilation and heat dissipation.
3. When adopting rack installation, the UPS must be installed in a standard 19-inch equipment rack at least 400mm deep. The user should provide the installation fittings and screws in the rack.

2.3 Tower Installation

2.3.1 Installing Single Power Module

Use the following steps to install the UPS systems that contain only one power module and no battery module. These power modules include GXT1000-RT, GXT1000L-RT, GXT2000L-RT and GXT3000L-RT.

1. Take out a pair of support bases delivered with the power module, snap it up in the direction shown in the left figure below to make a base, and put it down flat on the installation surface, as shown in the right figure below; likewise, make another base using another pair of support bases, and put it down flat on the installation surface.

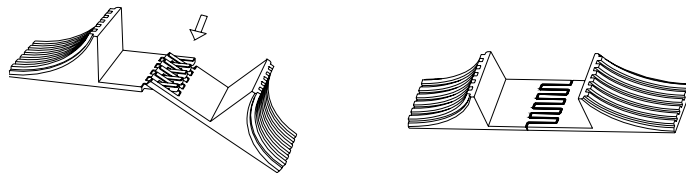

Figure 2-1 Making base

2. As shown in the left figure below, move the two bases to appropriate positions, and put the power module gently down on the bases; then push the power module gently in the directions shown in the right figure below to position it evenly on the two bases.

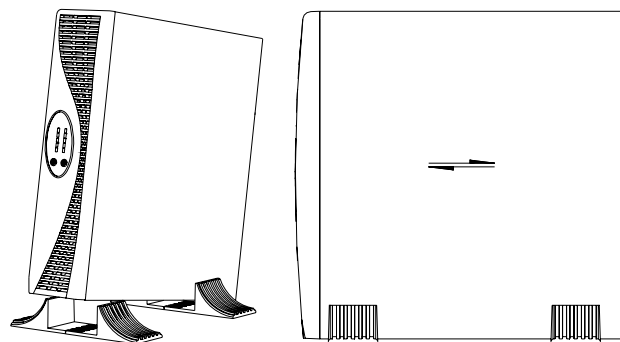

Figure 2-2 Positioning power module

2.3.2 Installing Power Module Plus Battery Module

Use the following steps to install the standard UPS systems that contain a power module and a battery module (i.e., GXT2000-RT plus GXT2000-BAT; and GXT3000-RT plus GXT3000-BAT).

1. Take out a pair of support bases delivered with the power module, and a support base extension delivered with the battery module, use step 1 in section 2.3.1 to fit them together to make a base, and put it down flat on the installation surface, as shown in Figure 2-3; likewise, make another base and put it down flat on the installation surface.

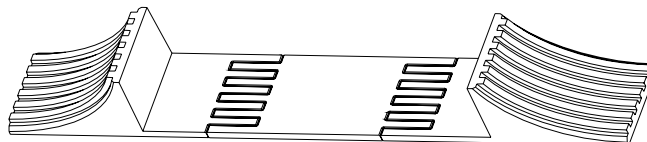

Figure 2-3 Making base

2. Use step 2 in section 2.3.1 to put the power module and battery module on the bases, with the power module in the right position to facilitate cable connection, as shown in Figure 2-4.

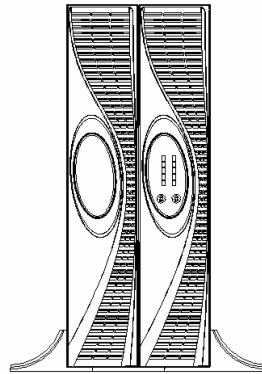

Figure 2-4 Positioning modules

2.4 Rack Installation

2.4.1 Installing Single Power Module

Use the following steps to install the UPS systems that contain only one power module and no battery module. These power modules include GXT1000-RT, GXT1000L-RT, GXT2000L-RT and GXT3000L-RT.

1. Take out the pair of brackets delivered with the power module; remove the four flat screws M4*8 on both sides of the module, as shown in Figure 2-5; and fix the brackets onto both sides of the module using the flat screws, as shown in Figure 2-6.

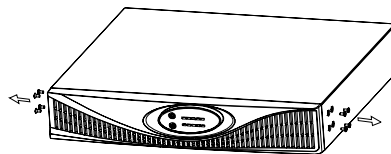

Figure 2-5 Removing flat screws

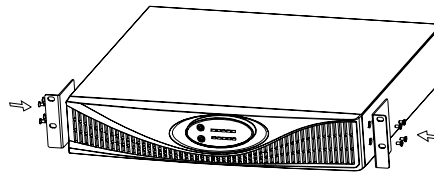

Figure 2-6 Installing brackets

2. Place the power module onto the slide rail in the rack in the direction shown in the following figure, and push it into place along the slide rail. Fix the module onto the rack using four screws (provided by the user), as shown in the figure below.

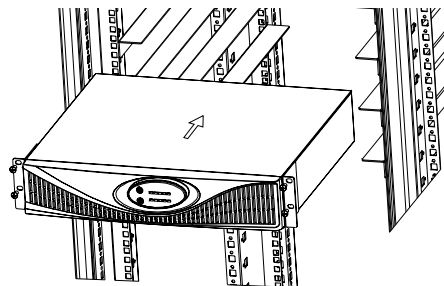

Figure 2-7 Installing power module

2.4.2 Installing Power Module Plus Battery Module

Use the following steps to install the standard UPS systems that contain a power module and a battery module (i.e., GXT2000-RT plus GXT2000-BAT; and GXT3000-RT plus GXT3000-BAT).

1. Take out a pair of brackets respectively delivered with the power module and battery module, use step 1 in section 2.4.1 to fit the brackets onto both sides of the two modules.
2. Use step 2 in section 2.4.1 to install the power module and battery module on the rack one by one, with the power module in the lower position to facilitate cable connection, as shown in Figure 2-8.

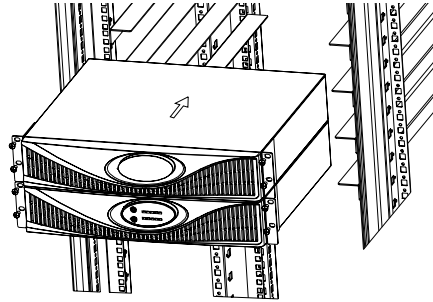

Figure 2-8 Installing modules

2.5 Cable Connection

2.5.1 Connecting Battery Cable

Battery cable connection is required for long back-up time UPS systems and standard UPS systems that contain a power module and a battery module.

Power module plus battery module system

Take out the battery connection cable delivered with the battery module, plug one end of the cable into the external battery socket on the rear panel of the power module, and the other end into any battery socket on the rear panel of the battery module.

Long back-up time system

Warning

1. Batteries have represent a potentially dangerous source of energy. Only professionals shall make battery cable connection for long back-up time UPS systems.
2. The external battery voltage must comply with the power module's requirements on external battery voltage (see section 5.2).

Use the following steps to connect the battery cable for the long back-up time UPS.

1. Open the battery breaker.
2. Take out the battery cable delivered with the power module, (a plug at one end and three OT terminals at the other).
3. Connect the three OT terminals respectively labeled "+", "-", and "G" to the battery's positive terminal, negative terminal and the PE terminal of the battery cabinet (refer to the Battery Cabinet User Manual) respectively.
4. Plug the battery cable into the external battery socket on the rear panel of the power module.

 **Note**

The external battery cable delivered with the long back-up time power module is 1.8m long. If users need a longer one, please consult the distributor. There is a limit to the length of the external battery cable to ensure normal operation of the UPS.

2.5.2 Connecting Input And Output Cables

 **Warning**

1. The max output current of each load output shall not exceed the current marked by screenprint at the output sockets and output terminal block, the total output power shall not exceed 0.7kW for 1kVA UPS, 1.4kW for 2kVA UPS, and 2.1kW for 3kVA UPS.
2. Make sure that the input plug and load plug match the power module's input socket and output socket respectively.
3. Non-professionals shall not make cable connection to the output terminal block at the rear panel of the 3kVA power module; when connecting load cable to the output terminal block, make sure that the neutral line and live line are not reversed connected.

Connect the input cable between the user's mains socket and the input socket of the power module, and insert the load plug into the output socket of the power module.

2.5.3 Connecting Communication Cable

DB9 communication port

Where users need to use the single UPS monitoring software delivered with the power module to monitor the UPS, in communication cable connection, just locate the RS232 cable delivered with the power module, and insert the two cable plugs respectively into the RS232 port of the computer and the DB9 port at the rear panel of the power module.

The DB9 port can be used for dry contact communication as well as RS232 serial communication. Its pin assignment is shown in Figure 2-9, the pin description appears from Table 2-3, and its dry contact port principle is shown in Figure 2-10.

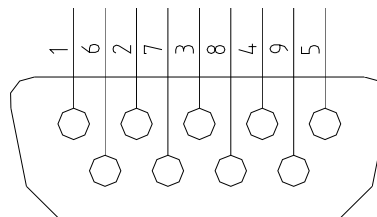

Figure 2-9 DB9 port's pin assignment

Table 2-3 DB9 port's pin description

Pin	Description	Remark
1, 7	Low Battery (output dry contact)	1. Pin1, Pin7 dry contact output: open when the battery voltage is normal, shorted when the battery voltage is low. 2. Pin9, Pin8 dry contact output: open when the UPS is not on battery, shorted when the UPS is on battery. 3. Pin4, Pin5 dry contact input: in Battery mode, when at high level (5~12Vdc, for more than 20s), the UPS is turned off; when open or at low level input, the UPS maintains the original state.
2	UPS RxD (RS232 standard)	
3	UPS TxD (RS232 standard)	
4, 5	Remote Inverter Off in Battery Mode	
5	Common GND	
6	NC	
8, 9	On Battery (output dry contact)	

 **Note**

The input signal current shall not exceed 10mA, the output dry contact voltage shall not exceed 30Vdc.

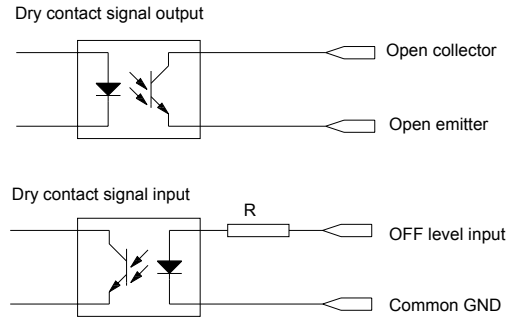

Figure 2-10 Dry contact port schematic diagram

SNMP card slot

For those that use the SNMP card to monitor the UPS, please refer to the SNMP Card User Manual for the SNMP card installation and communication connection instructions.

Chapter 3 Operation

3.1 Operator Control And Display Panel

Figure 3-1 shows the operator control and display panel of the power module, which provides ten LED indicators and two control buttons: ON/Alarm silence button and OFF button.

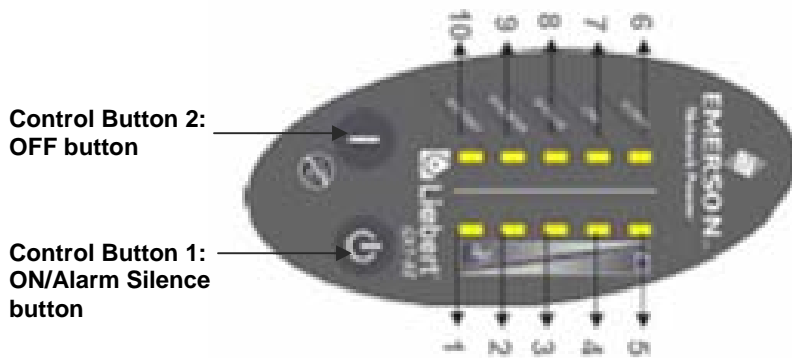

Figure 3-1 Operator control and display panel of power module

Control buttons

Control Button 1: ON/Alarm silence button

The ON/Alarm silence button provides the following three functions:

- 1) Turn on the inverter: Pressing and holding the ON/Alarm silence button for one second can turn on the inverter.
- 2) Silence the audible alarm in Battery mode: In Battery mode, when the buzzer beeps every 3.3s, pressing and holding the ON/Alarm silence button for one second can silence the buzzer.
- 3) Initiate battery test: In Normal mode, pressing and holding the ON/Alarm silence button for one second can initiate the battery test.

Note

The alarm silencing function of the ON/Alarm silence button is valid only for the one beep per 3.3s audible alarm in Battery mode, and invalid for any other UPS audible alarms.

Control Button 2: OFF Button

The OFF button provides the following two functions:

- 1) Turn off the inverter: in Normal mode or Battery mode, pressing and holding the OFF button for one second can turn off the inverter.
- 2) Transfer the UPS to Standby state: in Bypass mode, pressing and holding the OFF button for one second can turn off the bypass output and transfer the UPS to Standby state.

LED indicators

The indications of the BATTERY indicator, INVERTER indicator, BYPASS indicator, LINE indicator and ALARM indicator are described in Table 3-1.

Table 3-1 LED indication

BATTERY indicator (green)	It illuminates when the UPS is on battery and the battery voltage is not too high, flashes when the battery is faulty or the charging voltage is too high
INVERTER indicator (green)	It illuminates when the inverter is in normal operation, flashes when the inverter is faulty
BYPASS indicator (green)	It illuminates when the UPS is on bypass.
LINE indicator (green)	It illuminates when the mains input is normal, flashes when abnormal, and goes off when it fails
ALARM indicator (red)	It is on in the event of a UPS fault, off otherwise.

The buzzer and the ten indicators combine to indicate the UPS operating status and faults, as illustrated in Table 3-2:

Table 3-2 Audible alarm and LED indication of UPS operating status and faults

S/ N	Operating status		LED number (identified in Figure 3-1)										Audible alarm	
			1	2	3	4	5	6	7	8	9	10		
1	Normal mode	0%~25% load					●		●		●			None
2		26%~50% load				●	●		●		●			None
3		51%~75% load			●	●	●		●		●			None
4		76%~100% load		●	●	●	●		●		●			None
5		101%~105% load	●	●	●	●	●		●		●			None
6		>105% load	●	●	●	●	●		●		●			Twice every 1s
7	Battery mode	0%~25% battery capacity	●								●	●	Once every 1s	
8		26%~50% battery capacity	●	●							●	●	Once every 3.3s	
9		51%~75% battery capacity	●	●	●						●	●	Once every 3.3s	
10		76%~95% battery capacity	●	●	●	●					●	●	Once every 3.3s	
11		>96% battery capacity	●	●	●	●	●				●	●	Once every 3.3s	
12		>105% load	○	○	○	○	○				●	●	Twice every 1s	
13	Shortcircuit fault		●					●	○	○			Continuous	
14	Charger fault			●				●	○	○			Continuous	
15	Overheating fault				●			●	○	○			Continuous	
16	Fan failure					●		●	○	○	○	○	Once every 1s	
17	Rectifier fault						●	●	○	○			Continuous	
18	Inverter fault							●	○	○	○		Continuous	
19	Inverter overload		●	●	●	●	●	●	○	○			Continuous	
20	Battery overcharge (in Normal mode)		○	○	○	○	○		●		●	○	None	
21	Battery overcharge (in Standby state)		○	○	○	○	○		○			○	None	
22	No battery		○	○	○	○	○		●		○	○	6 times	

● ON; ○ depending on other conditions; □ Flash

Note

LED 1 is yellow, LED 6 is red, others are green.

3.2 Operation Mode

The UPS can be considered to be in the following operation modes:

Normal mode

When the input mains voltage is within the specifications, the load is supplied by the inverter, which draws power from the rectifier; meanwhile, the charger charges the battery. When in Normal mode, the LINE indicator and INVERTER indicator on the operator panel are on.

Bypass mode

In the event of an overload, inverter fault, overheating or rectifier fault condition during Normal mode, the UPS will transfer to Bypass mode. In Bypass mode, the load is supplied by the bypass AC source, which comes directly from the AC mains input; meanwhile, the charger charges the battery. When the UPS works in Bypass mode, the LINE indicator and BYPASS indicator are on, the INVERTER indicator is off.

Note

1. If the UPS transfers from Normal mode to Bypass mode three times within twenty minutes due to overload, it will remain in Bypass mode afterwards whether the overload condition is removed or not.
 2. In the event of a mains failure or mains voltage/frequency outside the specifications when the UPS is in Bypass mode, the UPS will shut down and cease supplying power to the load.
-

Battery mode

In the event of a mains failure or mains voltage/frequency outside the specifications when the UPS is in Normal mode, the rectifier and charger will become inoperative and the battery will begin to discharge and supply the load through the inverter. When the UPS is in Battery mode, the BATTERY indicator and the INVERTER indicator are on.

Note

In the event of an inverter fault, internal overheating or other fault conditions in Battery mode, the inverter will become inoperative.

3.3 Operating Instructions

3.3.1 Turning On And Completely Powering Down The UPS

Note

The battery is fully charged before delivery. However, storage and transportation will inevitably cause some charge loss. Therefore, it is advisable to charge the battery for 8 hours before using it, so as to ensure adequate battery **autonomy**.

Turning on the UPS

Users can use the following two methods to turn on the UPS:

1. Connect the mains input to the UPS, and manually turn on the UPS into Normal mode
Connect the mains input to the UPS, press and hold the ON button for one second until the buzzer beeps. At this point, the UPS begins to conduct self-test. Seconds later, the UPS will

begin to operate in Normal mode; meanwhile, the LINE indicator, INVERTER indicator, load/battery capacity indicators (LEDs 1~5) will turn on.

 **Note**

The UPS provides automatic restart function, i.e., the inverter will restart automatically to allow the UPS to operate in Normal mode when the mains power recovers after the UPS shuts down. This function can be enabled through the background monitoring software, and is also enabled by default.

2. With no mains input fed to the UPS, turn on the UPS manually into Battery mode

With no mains input fed to the UPS, hold and press the ON button for one second until the buzzer beeps. At this point, the inverter turns on, and the UPS will begin to operate in Battery mode. Meanwhile, the BATTERY indicator, INVERTER indicator, load/battery capacity indicators (LEDs 1~5) will turn on.

Completely powering down the UPS

The UPS can be powered down completely from Normal mode, Battery mode, and Bypass mode. The procedures are as follows:

1. Completely power down the UPS from Normal mode

Hold and press the OFF button for one second until the buzzer beeps. At this point, the UPS inverter turns off, the UPS ceases output and transfers to standby state, the LINE indicator and LED 5 are on. In standby state, the UPS is not completely powered down. To completely power down the UPS, disconnect the mains input to the UPS.

2. Completely power down the UPS from Battery mode

Just hold and press the OFF button for one second, and the UPS will shut down and cease output.

3. Completely power down the UPS from Bypass mode

Hold and press the OFF button for one second, and the UPS will cease output and transfer to standby state. In standby state, the UPS is not completely powered down. To completely power down the UPS, disconnect the mains input to the UPS.

3.3.2 Conducting Battery Test

In UPS operation, users can manually initiate battery test to check the battery conditions. There are two methods to initiate the battery test:

1. Through the ON/Alarm silence button

In Normal mode, press and hold the ON/Alarm silence button for one second until the buzzer beeps. At this point the LEDs 6~10 will flash cyclically, indicating the battery test has started. The battery test will last for five seconds.

In the event of a battery fault during battery test, the UPS will transfer to Normal mode automatically.

2. Through the background monitoring software

Users can also initiate battery test through the background monitoring software. For details, please refer to the UPS Monitoring Software User Manual.

Chapter 4 Maintenance

4.1 Battery Maintenance

The battery is a key component of the UPS system. The battery life depends on the ambient temperature, charge and discharge times. High ambient temperature and deep discharge will shorten the battery life.

1. Keep the ambient temperature between 15°C and 25°C.
2. To prevent small current discharge, the battery discharge duration should not exceed 48 hours.
3. If the UPS hasn't been used for a long time (or if the battery hasn't been charged for up to 3 months at specified ambient temperature, or up to 2 months at high ambient temperature) please charge it for at least 12 hours.

4.2 Replacing Output Fuse

Warning

1. Before replacing the output fuse, please disconnect the UPS input and switch off the UPS output.
 2. Only the same model of fuse can be used to replace the old one.
-

Only 3kVA power modules provide an output fuse (see Figure 1-6), which is provided for the IEC output socket. No fuse is provided for the output terminal block.

Procedures for replacing the fuse are as follows:

1. Remove the fuse holder from the rear panel of the power module by turning a flat head screwdriver counter-clockwise;
2. Take out the fuse from the fuse holder, and put a new one in it;
3. Replace the fuse holder by turning the flat head screwdriver clockwise.

4.3 Checking UPS Functions

Every time when conducting field maintenance, please check the regular functions of the UPS, including:

1. The UPS operating status

If the mains voltage is within the specifications, the UPS should operate in Normal mode; if the mains voltage is abnormal, the UPS should operate in Battery mode. In both cases, there should be no fault indication.

2. The transfer between the UPS operation modes:

Disconnect the mains input to simulate a mains failure, the UPS should transfer to Battery mode and operate normally; then recover the mains input, the UPS should transfer back to Normal mode and operate normally.

3. The LED indication of the UPS

During the check processes stated above, check that the LED indication of the UPS is in line with the UPS operation mode.

4.4 Troubleshooting

In the event of an UPS fault, troubleshoot according to Table 4-1. If the fault persists, seek immediate assistance from the local Emerson customer service office.

Table 4-1 UPS troubleshooting table

S/N.	Fault conditions	Possible cause	Actions to take
1	Pressing the ON button does not turn on the UPS	The button is not held down long enough	Press and hold the ON button for one second until the buzzer beeps, and the UPS will start
		No battery is connected to the UPS	Connect battery to the UPS
		The battery voltage is too low	Charge the battery first, and then turn on the inverter
		Battery damaged	Request professional to replace the battery
		UPS internal fault exists	Seek technical assistance from local Emerson customer service office
2	The AC mains is normal, but the UPS has no input power	The AC input overcurrent protection switch at the rear panel of the power module cut off the mains input (due to the existence of input overcurrent fault conditions)	Press the AC input overcurrent protection switch button to reconnect the mains input to the UPS
3	The LINE LED flashes or is off	The mains voltage or frequency is outside the specifications	Check the input voltage, frequency and the AC input overcurrent protection switch. Disconnect the load to prevent UPS shut down from causing any damage when the battery voltage reaches the end-of-discharge point
4	The ALARM LED and LEDs 1~5 light up, the buzzer beeps	Overload	Turn off non-critical load
5	Output overload, no output, no transfer to Bypass mode	The UPS ceased output due to bypass overload. The bypass voltage or frequency is outside the specifications	Turn off non-critical load, and check the input voltage and frequency
6	Battery autonomy time is short	Battery not fully charged	Charge the battery for 8 hrs on end
7	In Battery mode, only LED 1 illuminates among LEDs 1~5	The battery voltage is too low	Disconnect the load immediately to prevent UPS shut down from causing any damage when the battery voltage reaches the end-of-discharge point
8	The ALARM LED and LED 4 illuminate, the buzzer beeps every second	Fan failure	Check that the air exhaust is not obstructed, and that there is free air flow. If the fault persists, please seek technical assistance from local Emerson customer service office

S/N.	Fault conditions	Possible cause	Actions to take
9	The ALARM LED and LED 1 lights up, the buzzer beeps	UPS has no output due to output shortcircuit	Completely power down the UPS and check the load for shortcircuit. If the fault persists after removing the load, please seek technical assistance from local Emerson customer service office.
10	The ALARM LED and LED 3 lights up, the buzzer beeps	UPS overheating	Check the UPS for overload and fan obstruction conditions, check that the ambient temperature does not exceed 40°C. Completely power down the UPS, wait 10min for it to cool down, and turn it on afterwards. If the fault persists, please seek technical assistance from local Emerson customer service office
11	The INVERTER LED flashes, the ALARM LED lights up, the buzzer beeps	Inverter fault	Seek technical assistance from local Emerson customer service office
12	The ALARM LED and LED 5 lights up, the buzzer beeps	Rectifier fault	Seek technical assistance from local Emerson customer service office
13	The ALARM LED and LED 2 lights up, the buzzer beeps	The battery charger in the power module fails	Seek technical assistance from local Emerson customer service office
14	3kVA UPS IEC output socket has no output	The fuse is blown out due to overload	Power down and turn off the UPS, replace the fuse, disconnect the load, turn on the UPS again, and check whether the output voltage is normal. If the fault persists, seek technical assistance from local Emerson customer service office

When reporting UPS fault, please provide the machine model and machine serial No. (provided on the nameplate).

Chapter 5 Specifications

5.1 Mechanical

Module	W×H×D (mm)	Weight (kg)
Power module GXT1000-RT	440×87×400	17.5
Power module GXT1000L-RT	440×87×400	7.8
Power module GXT2000-RT	440×87×400	8.6
Power module GXT2000L-RT	440×87×400	9.6
Power module GXT3000-RT	440×87×400	9.0
Power module GXT3000L-RT	440×87×400	10.0
Battery module GXT2000-BAT	440×87×400	20.5
Battery module GXT3000-BAT	440×87×400	21.5

5.2 Electrical

Model		GXT 1000-RT	GXT 1000L-RT	GXT 2000-RT	GXT 2000L-RT	GXT 3000-RT	GXT 3000L-RT
Rating		1000VA/700W		2000VA/1400W		3000VA/2100W	
Input	Input system	1-phase, plus PE					
	Rated voltage	220Vac / 230 Vac / 240 Vac					
	Voltage range	1. 176~288Vac, full load 2. <176Vac, linear derating 3. 120Vac, half load					
	Frequency	50Hz±10%					
	Power factor	0.99 (conditions: rated voltage, full pure resistive load, fully charged battery)					
Output	Output system	1-phase, plus PE					
	Power factor	0.7					
	Voltage	220 Vac / 230 Vac / 240 Vac +/-2%					
	Line regulation	≤2%(0~100% linear load)					
	Load regulation	≤2%(0~100% linear load)					
Output	Voltage harmonic distortion (rated input voltage, rated input frequency)	≤2%(0 ~100% linear load) ≤5%(0 ~100% non-linear load)					
	Dynamic transient response	IEC62040-3 Class 1					
	Dynamic response recovery	IEC62040-3 (60ms) Class 1					
	Frequency	The output frequency synchronizes with the bypass frequency when the bypass frequency is in the range of 50Hz±10%, with the phase difference less than 3 degrees; the output frequency is 50Hz when the bypass frequency is outside specifications or the bypass voltage is lower than 120Vac					
	Frequency synchronization speed	1 Hz/s					

Model		GXT 1000-RT	GXT 1000L-RT	GXT 2000-RT	GXT 2000L-RT	GXT 3000-RT	GXT 3000L-RT
Rating		1000VA/700W		2000VA/1400W		3000VA/2100W	
	Inverter overload capability (in Normal mode, 25°C)	<105%		continuous operation			
		105%~125%		5min			
		125%~150%		1min			
		150%~200%		10s			
		>200%		0.25s			
	Inverter overload capability (in Battery mode, 25°C)	<105%		continuous operation			
		>105%~125%		degression from 60s~30s			
		>125%		0.25s			
Bypass overload capability	100%~150%		5min				
	151%~200%		1min				
Crest factor	3:1						
Bypass operating voltage	121Vac~253Vac						
Transfer time	Normal<—>Battery: 0ms						
DC component	≤200mV						
Efficiency	Battery mode: ≥83% (rated battery voltage, full linear load) Normal mode: ≥88% (rated mains voltage, full linear load, battery fully charged)						
External battery voltage	36Vdc			72Vdc			
Charging current	1A	7A	1A	8A	1A	8A	
Battery	Qty. ×Volts. ×Capacity	3×12V×7.2 Ah	-	6×12V×7. 2Ah	-	6×12V×9 Ah	-
	Manufacturer / model	CSB/GP12 72F2 or Panasonic equivalent	-	CSB/GP1 272F2 or Panasonic equivalent	-	CSB/HRL 1234WF2 or Panasonic equivalent	-
	Autonomy time (25°C)	≥5min at full load (standard type)					
	Charging duration	90% of battery capacity in 5 hrs (standard type)					
Noise (within 1m)	GXT1000-RT(L): 43dB GXT2000-RT(L), GXT3000-RT(L): 45dB						
Protection	IP21 (static state)						

5.3 EMS

Item	Standard	Level
ESD immunity	IEC61000-4-2	Level 3, criterion B
REF immunity	IEC61000-4-3	Level 3, criterion A
EFTB immunity	IEC61000-4-4	Level 4, criterion A
Surge immunity	IEC61000-4-5	Level 4, criterion B
Lightening protection	YD/T 944	Level I, 6kV/3kA

5.4 EMI

Item	Standard	Level
Limitation of emission of input harmonic currents	EN61000-3-2	-
Limitation of voltage changes, voltage fluctuations and flicker	EN61000-3-3	-
Conduction	EN/IEC62040-2	Class B
Emission	EN/IEC62040-2	Class B

5.5 Environmental

Item	Normal range
Ambient temperature	0°C~40°C
Relative humidity	5%~95%
Altitude	Lower than 1500m: no derating; 1500m~3000m: 1% derating for every 100m rise
Storage temperature	-25°C~55°C (excluding battery)

5.6 Safety

Comply with EN62040-1-1 and CE requirements.